

Goodrive28 Series Flexible General-Purpose VFD User Manual



Preface

Overview

Thank you for purchasing INVT Goodrive28 series variable-frequency drive (VFD). If not otherwise specified, the VFD mentioned in this manual refers to Goodrive28 series VFD. The VFD can be widely applied in industries such as machine tools, textiles, printing and packaging, food, lithium batteries, logistics, 3C, plastics, cables, and HVAC.

This manual mainly describes the methods of mechanical installation, electrical installation, operation methods, commissioning, maintenance and troubleshooting of the VFD. Read the manual carefully before installing and using the VFD.

Readers

Personnel with electrical professional knowledge (such as qualified electrical engineers or personnel with equivalent knowledge).

Change history

The manual is subject to change irregularly without prior notice due to product version upgrades or other reasons.

| No. | Change description | Version | Release date |
|-----|--------------------|---------|--------------|
| 1 | First release. | V1.0 | April 2025 |

Contents

| | |
|---|-----------|
| 1 Safety precautions | 1 |
| 1.1 Safety declaration..... | 1 |
| 1.2 Safety level definition..... | 1 |
| 1.3 Personnel requirements..... | 1 |
| 1.4 Safety guidelines | 2 |
| 2 Product overview | 5 |
| 2.1 Product nameplate and model | 5 |
| 2.2 Product specifications..... | 5 |
| 2.3 Product ratings | 8 |
| 2.4 Product heat dissipation | 9 |
| 2.5 Product dimensions and weight | 10 |
| 2.6 Product structure..... | 11 |
| 2.7 System configuration | 13 |
| 2.8 Quick startup | 15 |
| 3 Mechanical installation..... | 16 |
| 3.1 Unpacking inspection..... | 16 |
| 3.2 Preparing..... | 16 |
| 3.2.1 Installation environment and site | 17 |
| 3.2.2 Installation direction..... | 18 |
| 3.2.3 Installation space | 18 |
| 3.3 Installation and uninstallation | 19 |
| 3.3.1 Installation | 20 |
| 3.3.2 Disassembly..... | 23 |
| 4 Electrical installation..... | 25 |
| 4.1 Insulation inspection..... | 25 |
| 4.2 Checking compatible grounding systems | 25 |
| 4.2.1 EMC filter grounding capacitor..... | 25 |
| 4.2.2 Ground-to-phase VDR | 26 |
| 4.2.3 When to disconnect the EMC filter or VDR: TN-S, IT, corner-grounded delta and midpoint-grounded delta systems..... | 26 |
| 4.2.4 Guidelines for installing the VFD in TT systems | 27 |
| 4.2.5 Identifying grid grounding systems..... | 28 |
| 4.2.6 Disconnecting the internal EMC filter or VDR, for frames A to E..... | 29 |
| 4.3 Cable selection and routing | 31 |
| 4.3.1 Cable selection..... | 31 |
| 4.3.2 Cable arrangement | 33 |
| 4.4 Main circuit wiring | 34 |

| | |
|---|-----------|
| 4.4.1 Main circuit wiring..... | 34 |
| 4.4.2 Main circuit terminals | 34 |
| 4.4.3 Wiring procedure..... | 37 |
| 4.5 Control circuit wiring | 38 |
| 4.5.1 Control circuit wiring | 38 |
| 4.5.2 Control circuit terminals..... | 39 |
| 4.5.3 Input/output signal wiring..... | 41 |
| 4.6 Power distribution protection | 46 |
| 5 Keypad operation guidelines..... | 48 |
| 5.1 Keypad introduction..... | 48 |
| 5.2 Local LED keypad display and operation | 48 |
| 5.2.1 Keypad panel..... | 49 |
| 5.2.2 Keypad display | 50 |
| 5.2.3 Operation procedure | 51 |
| 5.3 External LED keypad display and operation..... | 54 |
| 5.3.1 Keypad panel..... | 55 |
| 5.3.2 Keypad display | 56 |
| 5.3.3 Operation procedure | 57 |
| 5.4 External LCD keypad display and operation | 60 |
| 5.4.1 Keypad panel..... | 60 |
| 5.4.2 Keypad functions | 62 |
| 5.4.3 Operation procedure | 62 |
| 6 Commissioning | 75 |
| 6.1 Motor parameter setting | 76 |
| 6.1.1 Motor type selection | 76 |
| 6.1.2 Rated motor parameter setting..... | 76 |
| 6.1.3 Motor switchover | 78 |
| 6.2 Parameter autotuning setting..... | 79 |
| 6.2.1 Motor parameter autotuning..... | 79 |
| 6.2.2 Motor inertia identifying | 80 |
| 6.3 Running command selection | 81 |
| 6.4 Frequency setting | 85 |
| 6.4.1 Combination of frequency setting source..... | 87 |
| 6.4.2 Frequency setting method..... | 88 |
| 6.4.3 Frequency fine-tuning..... | 101 |
| 6.5 Speed control mode selection | 102 |
| 6.6 Torque setting method selection..... | 103 |
| 6.6.1 Torque setting method selection | 103 |
| 6.6.2 Method for switching between speed control and torque control | 104 |
| 6.7 Start/stop settings | 105 |

| | |
|--|------------|
| 6.7.1 Start settings | 105 |
| 6.7.2 Stop settings..... | 107 |
| 6.7.3 Power-off restart | 111 |
| 6.8 Control performance regulation | 112 |
| 6.8.1 Space vector control performance optimization | 112 |
| 6.8.2 Vector control performance optimization | 119 |
| 6.9 Input and output..... | 126 |
| 6.9.1 Digital input and output | 126 |
| 6.9.2 Analog input and output terminal functions | 138 |
| 6.9.3 High-speed pulse input and output terminal functions | 143 |
| 6.10 RS485 communication | 148 |
| 6.11 Monitoring parameters..... | 151 |
| 6.11.1 Group P07—Human-machine interface | 151 |
| 6.11.2 Group P17—Basic status viewing | 156 |
| 6.12 Protection parameter setting..... | 161 |
| 6.12.1 Overvoltage stall protection | 161 |
| 6.12.2 Current-limit protection | 163 |
| 6.12.3 Frequency decrease at sudden power failure | 164 |
| 6.12.4 Cooling fan control..... | 165 |
| 6.12.5 Dynamic braking | 166 |
| 6.12.6 Safe torque off..... | 167 |
| 6.13 Typical applications | 168 |
| 6.13.1 Counting | 168 |
| 6.13.2 Sleep and wakeup | 168 |
| 6.13.3 Switchover between FWD run and REV run..... | 169 |
| 6.13.4 Jump frequency | 171 |
| 6.13.5 Wobbling frequency | 172 |
| 7 Communication | 174 |
| 7.1 Standard communication interface..... | 174 |
| 7.2 Communication data address..... | 174 |
| 7.2.1 Function parameter address | 174 |
| 7.2.2 Non-function parameter address | 175 |
| 7.3 Modbus networking..... | 178 |
| 7.3.1 Network topology | 179 |
| 7.3.2 RTU mode | 180 |
| 7.3.3 RTU command code..... | 183 |
| 7.3.4 Fieldbus scale | 187 |
| 7.3.5 Error message response | 188 |
| 7.3.6 Communication commissioning | 189 |
| 8 Fault handling | 191 |

| | |
|--|------------|
| 8.1 Fault indication and reset | 191 |
| 8.2 Faults and solutions | 191 |
| 8.2.1 Common faults and solutions | 192 |
| 8.2.2 Other status | 201 |
| 8.3 Analysis on common faults | 202 |
| 8.3.1 Motor fails to work | 202 |
| 8.3.2 Motor vibrates | 203 |
| 8.3.3 Overvoltage | 204 |
| 8.3.4 Undervoltage | 205 |
| 8.3.5 Overcurrent | 206 |
| 8.3.6 Motor overheating | 207 |
| 8.3.7 VFD overheating | 208 |
| 8.3.8 Motor stalls during ACC | 209 |
| 8.4 Countermeasures on common interference | 209 |
| 8.4.1 Interference problems of meter switch and sensors | 209 |
| 8.4.2 Interference on RS485 communication | 211 |
| 8.4.3 Failure to stop and indicator shimmering due to motor cable coupling | 212 |
| 8.4.4 Leakage current and interference on RCD | 212 |
| 8.4.5 Live device housing | 214 |
| 9 Inspection and maintenance | 215 |
| 9.1 Daily inspection and regular maintenance | 215 |
| 9.2 Cooling fan replacement | 216 |
| 9.3 Reforming | 217 |
| Appendix A Expansion card | 219 |
| A.1 Model definition | 219 |
| A.2 Specifications | 219 |
| A.3 Protocol parameter | 221 |
| A.4 Indicator | 222 |
| A.5 Expansion card installation and wiring | 226 |
| A.5.1 Expansion card installation procedure | 226 |
| A.5.2 Expansion card wiring | 227 |
| A.6 Commissioning | 229 |
| Appendix B Technical data | 233 |
| B.1 Derating due to temperature | 233 |
| B.2 Derating due to altitude | 235 |
| B.3 Derating due to carrier frequency | 235 |
| B.4 Grid specifications | 236 |
| B.5 Motor connection data | 237 |
| B.5.1 Motor cable length for normal operation | 237 |
| B.5.2 Motor cable length for EMC | 237 |

| | |
|---|------------|
| Appendix C Application standards | 239 |
| C.1 List of application standards | 239 |
| C.2 CE/TUV/UL/CCS certification | 239 |
| C.3 EMC compliance declaration | 240 |
| C.4 EMC product standard | 240 |
| Appendix D Dimension drawings | 241 |
| D.1 Keypad structure..... | 241 |
| D.2 Product outline dimensions | 242 |
| D.3 Flange mounting dimensions | 246 |
| Appendix E Peripheral accessories | 247 |
| E.1 Cable | 247 |
| E.1.1 Power cable..... | 247 |
| E.1.2 Control cable..... | 249 |
| E.2 Breaker, fuse, and electromagnetic contactor..... | 250 |
| E.3 Option | 251 |
| E.3.1 Reactor | 251 |
| E.3.2 Filter..... | 253 |
| E.3.3 Braking component | 254 |
| E.3.4 External keypad and mounting bracket..... | 256 |
| E.3.5 DIN rail mounting bracket | 256 |
| E.3.6 Accessory list..... | 257 |
| Appendix F STO function | 258 |
| F.1 Safety standards | 258 |
| F.2 Safety function description | 259 |
| F.3 Risk assessment..... | 260 |
| F.4 STO wiring..... | 260 |
| F.5 STO function terminal description | 262 |
| F.6 STO function logic table | 262 |
| F.7 STO channel delay description | 262 |
| F.8 Acceptance test | 263 |
| Appendix G Function parameter list | 266 |
| Group P00—Basic functions..... | 266 |
| Group P01—Start and stop control..... | 270 |
| Group P02—Parameters of motor 1..... | 275 |
| Group P03—Vector control of motor 1 | 280 |
| Group P04—V/F control of motor 1..... | 290 |
| Group P05—Input terminal functions..... | 295 |
| Group P06—Output terminal functions..... | 301 |
| Group P07—Human-machine interface | 307 |
| Group P08—Enhanced functions | 316 |

| | |
|---|-----|
| Group P09—PID control | 326 |
| Group P10—Simple PLC and multi-step speed control | 330 |
| Group P11—Protection parameters | 333 |
| Group P13—SM control | 340 |
| Group P14—Serial communication | 342 |
| Group P16—Customized communication functions..... | 348 |
| Group P17—Status viewing..... | 355 |
| Group P23—Communication expansion function group 1..... | 361 |
| Group P24—Communication expansion function group 2..... | 363 |
| Group P29—Expansion card status viewing..... | 368 |
| Group P34—Parameters of motor 2..... | 370 |
| Group P35—Vector control of motor 2 | 375 |
| Group P36—V/F control of motor 2..... | 384 |

1 Safety precautions





1.1 Safety declaration

Read this manual carefully and follow all safety precautions before moving, installing, operating and servicing the product. Otherwise, equipment damage or physical injury or death may be caused.

We shall not be liable or responsible for any equipment damage or physical injury or death caused due to failure to follow the safety precautions.

1.2 Safety level definition





To ensure personal safety and avoid property damage, you must pay attention to the safety symbols and warnings in the manual.

| Symbol | Name | Description |
|---|-------------------------|---|
|  | Danger | Severe personal injury or even death can result if related requirements are not followed. |
|  | Electric shock | Severe personal injury or even death can result if related requirements are not followed. As high voltage still presents in the bus capacitor after power off, wait for at least 5 minutes (depending on the warning symbols on the machine) after power off to prevent electric shock. |
|  | Warning | Personal injury or equipment damage can result if related requirements are not followed. |
|  | Electrostatic discharge | Equipment damage or internal component damage can result if related requirements are not followed. |
|  | Hot sides | You may get burnt if related requirements are not followed. |
| Note | Note | Slight personal injury or equipment damage can result if related requirements are not followed. |



1.3 Personnel requirements



Trained and qualified professionals: People operating the equipment must have received professional electrical and safety training and obtained the certificates, and must be familiar with all steps and requirements of equipment installing, commissioning, running and maintaining and capable to prevent any emergencies according to experiences.





1.4 Safety guidelines

| General principles | | | | | | | | | |
|---|---|-------|----------------------|------------------|-----------|-------------------|-----------|-------------------|-----------|
|  | <ul style="list-style-type: none"> Only trained and qualified professionals are allowed to carry out related operations. Do not perform wiring, inspection or component replacement when power supply is applied. Before performing these operations, ensure all the input power supplies have been disconnected, and wait for at least the time designated on the VFD. The minimum waiting time is listed in the following. <table border="1" style="margin-left: auto; margin-right: auto;"> <thead> <tr> <th style="background-color: #d9e1f2;">Model</th> <th style="background-color: #d9e1f2;">Minimum waiting time</th> </tr> </thead> <tbody> <tr> <td>1PH 220V 0.2–4kW</td> <td>5 minutes</td> </tr> <tr> <td>3PH 220V 0.2–15kW</td> <td>5 minutes</td> </tr> <tr> <td>3PH 380V 0.4–22kW</td> <td>5 minutes</td> </tr> </tbody> </table> | Model | Minimum waiting time | 1PH 220V 0.2–4kW | 5 minutes | 3PH 220V 0.2–15kW | 5 minutes | 3PH 380V 0.4–22kW | 5 minutes |
| Model | Minimum waiting time | | | | | | | | |
| 1PH 220V 0.2–4kW | 5 minutes | | | | | | | | |
| 3PH 220V 0.2–15kW | 5 minutes | | | | | | | | |
| 3PH 380V 0.4–22kW | 5 minutes | | | | | | | | |
|  | <ul style="list-style-type: none"> Do not modify the VFD unless authorized; otherwise fire, electric shock or other injury may result. The VFD cannot be used as an "emergency-stop device". The VFD cannot act as an emergency brake for the motor; it is a must to install a mechanical braking device. Prevent the screws, cables and other conductive parts from falling into the VFD. | | | | | | | | |
|  | <ul style="list-style-type: none"> The base may become hot when the VFD is running. Do not touch. Otherwise, you may get burnt. | | | | | | | | |
|  | <ul style="list-style-type: none"> The electrical parts and components inside the VFD are electrostatic sensitive. Take measurements to prevent electrostatic discharge when performing related operations. | | | | | | | | |

| Delivery | |
|---|---|
|  | <ul style="list-style-type: none"> Select appropriate tools for VFD delivery to avoid damage to the VFD, and take protective measures like wearing safety shoes and working uniforms to avoid physical injury or death. Protect the VFD against physical shock or vibration. Do not carry the VFD only by its front cover as the cover may fall off. |

| Installation | |
|---|---|
|  | <ul style="list-style-type: none"> Do not install the VFD on inflammables. In addition, prevent the VFD from contacting or adhering to inflammables. Do not install the damaged or incomplete VFD. Do not contact the VFD with damp objects or body parts. Otherwise, electric shock may result. |
|  | <ul style="list-style-type: none"> The installation site must be away from children and other public places. For |

| Installation | |
|---|--|
| | <p>details, see section 3.2.1 Installation environment and site.</p> <ul style="list-style-type: none"> • Connect the optional braking parts (such as braking resistors, braking units or feedback units) according to the wiring diagrams. • As VFD leakage current caused during running may exceed 3.5mA, ground properly and ensure the grounding resistance is less than 10Ω. The conductivity of PE grounding conductor is the same as that of the phase conductor. • L1, L2, and L3 are the power input terminals, while U, V, and W are the output motor-connection terminals. Connect the input power cables and motor cables properly; otherwise, the VFD may be damaged. • When the VFD is installed in a confined space (such as cabinet), it is necessary to provide protective devices (such as fireproof housing, electrical protective housing, mechanical protective housing, etc.) that meet the IP rating, and the IP rating shall comply with the relevant IEC standards and local regulations. |
| Commissioning | |
|  | <ul style="list-style-type: none"> • The VFD may start up by itself when power-off restart is enabled (P01.21=1). Do not get close to the VFD and motor. |
|  | <ul style="list-style-type: none"> • Do not switch on or switch off the input power supplies of the VFD frequently. • If the VFD has been stored without use for a long time, perform capacitor reforming (described in section 9.3 Reforming), inspection and pilot run for the VFD before the reuse. |
| Run | |
|  | <ul style="list-style-type: none"> • Close the VFD front cover before running; otherwise, electric shock may occur. • High voltage presents inside the VFD during running. Do not carry out any operation on the VFD during running except for keypad setup. The control terminals of the VFD form extra-low voltage (ELV) circuits. Therefore, you need to prevent the control terminals from connecting to accessible terminals of other devices. • During driving a synchronous motor, besides above-mentioned items, the following work must be done: <ul style="list-style-type: none"> ✓ All input power supplies have been disconnected, including the main power and control power. ✓ The synchronous motor has been stopped, and the voltage on output end of the VFD is lower than 36V. ✓ After the synchronous motor has stopped, wait for at least the time designated on the VFD. ✓ During operation, it is a must to ensure the synchronous motor cannot run again by the action of external load; it is recommended to install an |

| Run | |
|---|---|
| | effective external braking device or cut off the direct electrical connection between the synchronous motor and the VFD. |
| Maintenance | |
|  | <ul style="list-style-type: none"> Do not perform VFD maintenance or component replacement when the power is on. Otherwise, electric shock may result. Keep the VFD and its parts and components away from combustible materials and ensure they have no combustible materials adhered. |
|  | <ul style="list-style-type: none"> During maintenance and component replacement, take proper anti-static measures on the VFD and its internal parts. |
|  | <ul style="list-style-type: none"> Do not carry out insulation voltage-endurance test on the VFD, or measure the control circuits of the VFD with a megohmmeter. |
| Note | <ul style="list-style-type: none"> Use proper torque to tighten screws. |
| Disposal | |
|  | <ul style="list-style-type: none"> The VFD contains heavy metals. Dispose of a scrap VFD as industrial waste. |

2 Product overview

2.1 Product nameplate and model

Each VFD is affixed with a nameplate containing the basic product information and, depending on the actual certification, certification marks such as the CE mark.



Nameplate position. →

| | |
|--------------------------|---|
| Product nameplate | |
| Model | Model: GD28-1R1G-4 |
| Power | Power(Output): 1.1kW |
| Input | Input1: Normal Duty: AC 3PH 380V-480V 6.9A 47Hz-63Hz Input2: Heavy Duty: AC 3PH 380V-480V 5.8A 47Hz-63Hz |
| Output | Output1: Normal Duty: AC 3PH 0V-Input 3.7A 0Hz-599Hz Output2: Heavy Duty: AC 3PH 0V-Input 3A 0Hz-599Hz |
| | S/N: Made in China |
| | Shenzhen INV'T Electric Co.,Ltd. |

| | | |
|----------------------|-------------------------|--|
| Product model | GD28-1R1G-4 | |
| Product series | GD28: Goodrive28 series | Voltage class |
| | | S2: AC 1PH 200V - 240V 2: AC 3PH 200V - 240V 4: AC 3PH 380V - 480V |
| | Heavy load power | |
| | 1R1: 1.1kW | |
| | G: Constant torque load | |

2.2 Product specifications

| Item | | Specifications |
|---------------------|-----------------------|---|
| Input | Input voltage (V) | AC 1PH 200V-240V AC 3PH 200V-240V AC 3PH 380V-480V |
| | Input current (A) | See section 2.3 Product ratings. |
| | Input frequency (Hz) | 50Hz or 60Hz; Allowed range: 47-63Hz |
| Output | Output voltage (V) | 0-Input voltage |
| | Output current (A) | See section 2.3 Product ratings. |
| | Output power (kW) | See section 2.3 Product ratings. |
| | Output frequency (Hz) | 0-599Hz |
| Control performance | Control mode | Space voltage vector control (V/F), and sensorless vector control (SVC) |
| | Motor | Asynchronous motor (AM) and synchronous motor (SM) |
| | Speed ratio | For AMs: 1: 100 (SVC) For SMs: 1: 50 (SVC) |

| Item | | Specifications |
|--------------------------|-------------------------|---|
| | Speed control accuracy | $\pm 0.2\%$ (SVC) |
| | Speed fluctuation | $\pm 0.3\%$ (SVC) |
| | Torque response | < 10ms (SVC) |
| | Torque control accuracy | 5% (SVC) |
| | Starting torque | For AMs: 0.5Hz/200% (SVC) For SMs: 2.5 Hz/150% (SVC) |
| | Overload capacity | For heavy-load models: 150%/60s, 180%/10s For light-load models: 110%/60s, 150%/10s |
| External Interface | Analog input | Two analog inputs: AI1: 0–10V/0–20mA AI2: -10–10V/0–20mA Full-scale accuracy of 1% |
| | Analog output | One analog output: AO1: 0–10V/0–20mA Full-scale accuracy of 1% |
| | Digital input | Four regular inputs; max. frequency: 1kHz One high-speed input. Max. frequency: 50kHz Both NPN and PNP are supported, with PNP as the default. DI4 can be switched to provide the PTC function through the toggle switch. |
| | Digital output | One high-speed digital output. Max frequency: 50kHz Optional standard digital output, supporting both PNP and NPN modes. |
| | Relay output | One relay output RO1A: NO; RO1B: NC; RO1C: common Contact capacity: 3A/AC 250V, 1A/DC 30V |
| | Type-C interface | Powered by connecting to a PC through USB, allowing quick parameter viewing and configuration through host controller software without requiring the main power supply. |
| | Communication interface | RS485 communication, supporting the Modbus RTU communication protocol. |
| | Keypad display | Five-digit digital tube display, with six keys |
| Environment requirements | Running temperature | -10–+50°C, no derating for light load at 40°C, no derating for heavy load at 50°C  Note: Refer to section B.1 Derating due to |

| Item | | Specifications |
|-------|--------------------------------|---|
| | | temperature for use at heavy load above 50°C; refer to section B.1 Derating due to temperature for use at light load above 40°C. |
| | Storage temperature | -20°C–70°C |
| | Transport temperature | -20°C–70°C |
| | Altitude | For star-type grid, up to 4000m (13123ft) For delta-type grid, up to 2000m (6562ft) Derating is not required for use up to 1000m (3281ft). Above 1000m (3281ft), derate by 1% for every increase of 100m (328.1ft). |
| | Relative humidity (RH) | <95%RH, no condensation |
| | Vibration | <0.6g |
| | Pollution level | 3C2, 3S2, PD2 |
| | Ingress protection (IP) rating | IP20 |
| | Overvoltage category | OVC III |
| Other | Braking unit | Standard built-in braking unit |
| | Product certification* | UL CE |
| | Safety function* | TUV (SIL3) |
| | Mounting method | Wall mounting, DIN rail mounting, and flange mounting Note: Only models in frames A and B support rail mounting, which requires the selection of related options; only models in frames C, D, and E support flange mounting, which requires the selection of related options. |
| | Cooling method | 220V voltage class: natural cooling for 0.75kW and lower 380V voltage class: natural cooling for 1.1kW and lower Others: Forced air cooling |

 **Note:** The asterisk (*) indicates that the product is currently under certification.

2.3 Product ratings

| Product model | Heavy load | | | Light load | | |
|------------------|-------------------|-------------------|--------------------|-------------------|-------------------|--------------------|
| | Output power (kW) | Input current (A) | Output current (A) | Output power (kW) | Input current (A) | Output current (A) |
| AC 1PH 200V-240V | | | | | | |
| GD28-0R2G-S2 | 0.2 | 3.9 | 1.5 | 0.4 | 5.2 | 2 |
| GD28-0R4G-S2 | 0.4 | 5.3 | 2.5 | 0.75 | 7.4 | 3.3 |
| GD28-0R7G-S2 | 0.75 | 8.8 | 4.2 | 1.1 | 11 | 5.1 |
| GD28-1R1G-S2 | 1.1 | 13.2 | 6.5 | 1.5 | 13.4 | 7.5 |
| GD28-1R5G-S2 | 1.5 | 14.2 | 7.5 | 2.2 | 18.8 | 9.8 |
| GD28-2R2G-S2 | 2.2 | 20.6 | 10 | 4 | 23.8 | 12.5 |
| GD28-004G-S2 | 4 | 32 | 16 | - | - | - |
| AC 3PH 200V-240V | | | | | | |
| GD28-0R2G-2 | 0.2 | 2.2 | 1.5 | 0.4 | 3.3 | 2 |
| GD28-0R4G-2 | 0.4 | 4.1 | 2.5 | 0.75 | 5.6 | 3.3 |
| GD28-0R7G-2 | 0.75 | 6.8 | 4.2 | 1.1 | 8.1 | 5.1 |
| GD28-1R1G-2 | 1.1 | 10.3 | 6.5 | 1.5 | 11.5 | 7.5 |
| GD28-1R5G-2 | 1.5 | 9.3 | 7.5 | 2.2 | 11.8 | 9.8 |
| GD28-2R2G-2 | 2.2 | 12 | 10 | 4 | 13.7 | 12.5 |
| GD28-004G-2 | 4 | 20 | 16 | 5.5 | 26 | 21 |
| GD28-5R5G-2 | 5.5 | 21.7 | 20 | 7.5 | 28 | 26 |
| GD28-7R5G-2 | 7.5 | 33 | 30 | 11 | 43 | 39 |
| GD28-011G-2 | 11 | 44 | 42 | - | - | - |
| GD28-015G-2 | 15 | 60 | 55 | 22 | 72 | 64 |
| AC 3PH 380V-480V | | | | | | |
| GD28-0R4G-4 | 0.4 | 2.7 | 1.5 | 0.75 | 3.9 | 2 |
| GD28-0R7G-4 | 0.75 | 4.5 | 2.5 | 1.1 | 6 | 3.3 |
| GD28-1R1G-4 | 1.1 | 5.8 | 3 | 1.5 | 6.9 | 3.7 |
| GD28-1R5G-4 | 1.5 | 7.6 | 4.2 | 2.2 | 8.6 | 5.5 |
| GD28-2R2G-4 | 2.2 | 9.62 | 5.5 | 3 | 10.4 | 7 |
| GD28-003G-4 | 3 | 11.4 | 7.5 | 4 | 12.8 | 9.5 |
| GD28-004G-4 | 4 | 15.3 | 9.5 | 5.5 | 17.2 | 11.5 |
| GD28-5R5G-4 | 5.5 | 22.1 | 14 | 7.5 | 28.1 | 18 |
| GD28-7R5G-4 | 7.5 | 25 | 18.5 | 11 | 26.8 | 21 |
| GD28-011G-4 | 11 | 36 | 25 | 15 | 46 | 32 |
| GD28-015G-4 | 15 | 46 | 32 | 18 | 55 | 38 |
| GD28-018G-4 | 18 | 57 | 38 | 22 | 68 | 45 |
| GD28-022G-4 | 22 | 62 | 45 | 30 | 72 | 58 |

Note: The VFD input current is measured in cases where the input voltage is 220V/380V without additional reactors.

2.4 Product heat dissipation

| Product model | Entire machine standby power dissipation (W) | Entire machine full load power dissipation (W) | Heat dissipation (BTU/hr) | Air rate (m ³ /h) | Air rate (CFM) (ft ³ /min) |
|-------------------------|--|--|---------------------------|------------------------------|---------------------------------------|
| AC 1PH 200V-240V | | | | | |
| GD28-0R2G-S2 | 7 | 19 | 65 | - | - |
| GD28-0R4G-S2 | 7 | 27 | 92 | - | - |
| GD28-0R7G-S2 | 7 | 45 | 154 | - | - |
| GD28-1R1G-S2 | 7 | 67 | 229 | 20 | 12 |
| GD28-1R5G-S2 | 7 | 74 | 253 | 20 | 12 |
| GD28-2R2G-S2 | 7 | 112 | 382 | 20 | 12 |
| GD28-004G-S2 | 11 | 185 | 631 | 20 | 12 |
| AC 3PH 200V-240V | | | | | |
| GD28-0R2G-2 | 7 | 19 | 65 | - | - |
| GD28-0R4G-2 | 7 | 27 | 92 | - | - |
| GD28-0R7G-2 | 7 | 42 | 143 | - | - |
| GD28-1R1G-2 | 7 | 60 | 205 | 20 | 12 |
| GD28-1R5G-2 | 7 | 67 | 229 | 20 | 12 |
| GD28-2R2G-2 | 7 | 84 | 287 | 20 | 12 |
| GD28-004G-2 | 11 | 137 | 467 | 50 | 30 |
| GD28-5R5G-2 | 11 | 182 | 621 | 50 | 30 |
| GD28-7R5G-2 | 14 | 260 | 887 | 122 | 72 |
| GD28-011G-2 | 14 | 396 | 1351 | 122 | 72 |
| GD28-015G-2 | 16 | 621 | 2119 | 153 | 90 |
| AC 3PH 380V-480V | | | | | |
| GD28-0R4G-4 | 9 | 29 | 99 | - | - |
| GD28-0R7G-4 | 9 | 40 | 137 | - | - |
| GD28-1R1G-4 | 9 | 45 | 154 | - | - |
| GD28-1R5G-4 | 9 | 60 | 205 | 20 | 12 |
| GD28-2R2G-4 | 9 | 81 | 277 | 20 | 12 |
| GD28-003G-4 | 9 | 104 | 355 | 20 | 12 |
| GD28-004G-4 | 9 | 147 | 502 | 20 | 12 |
| GD28-5R5G-4 | 11 | 208 | 710 | 50 | 30 |
| GD28-7R5G-4 | 11 | 248 | 846 | 50 | 30 |
| GD28-011G-4 | 20 | 335 | 1143 | 122 | 72 |

| Product model | Entire machine standby power dissipation (W) | Entire machine full load power dissipation (W) | Heat dissipation (BTU/hr) | Air rate (m ³ /h) | Air rate (CFM) (ft ³ /min) |
|---------------|--|--|---------------------------|------------------------------|---------------------------------------|
| GD28-015G-4 | 20 | 468 | 1197 | 122 | 72 |
| GD28-018G-4 | 20 | 503 | 1716 | 153 | 90 |
| GD28-022G-4 | 20 | 577 | 1969 | 153 | 90 |

2.5 Product dimensions and weight

| Product model | Frame | Outline dimensions W×H×D (mm/in) | Packaging dimensions W×H×D (mm/in) | Net weight (kg) | Gross weight (kg) |
|-------------------------|-------|----------------------------------|------------------------------------|-----------------|-------------------|
| AC 1PH 200V–240V | | | | | |
| GD28-0R2G-S2 | A | 60×190×155/ 2.36×7.48×6.1 | 230×90×190/ 9.05×3.54×7.48 | 1.23 | 1.34 |
| GD28-0R4G-S2 | | | | | |
| GD28-0R7G-S2 | | | | | |
| GD28-1R5G-S2 | B | 70×190×155/ 2.75×7.48×6.1 | 230×90×190/ 9.05×3.54×7.48 | 1.27 | 1.47 |
| GD28-2R2G-S2 | | | | | |
| GD28-004G-S2 | C | 90×235×155/ 3.54×9.25×6.1 | 278×150×245/ 10.9×5.9×9.6 | 2.05 | 2.259 |
| AC 3PH 200V–240V | | | | | |
| GD28-0R2G-2 | A | 60×190×155/ 2.36×7.48×6.1 | 230×90×190/ 9.05×3.54×7.48 | 1.23 | 1.34 |
| GD28-0R4G-2 | | | | | |
| GD28-0R7G-2 | | | | | |
| GD28-1R1G-2 | B | 70×190×155/ 2.75×7.48×6.1 | 230×90×190/ 9.05×3.54×7.48 | 1.23 | 1.34 |
| GD28-1R5G-2 | | | | | |
| GD28-2R2G-2 | | | | | |
| GD28-004G-2 | C | 90×235×155/ 3.54×9.25×6.1 | 278×150×245/ 10.9×5.9×9.6 | 2.05 | 2.259 |
| GD28-5R5G-2 | | | | | |
| GD28-7R5G-2 | D | 130×250×185/ 5.11×9.84×7.28 | 325×190×235/ 12.8×7.5×9.3 | 3.55 | 4.05 |
| GD28-011G-2 | | | | | |
| GD28-015G-2 | E | 160×300×190/ 6.29×11.81×7.48 | 413×255×300/ 16.3×10×11.8 | 4.90 | 5.40 |
| AC 3PH 380V–480V | | | | | |
| GD28-0R4G-4 | A | 60×190×155/ 2.36×7.48×6.1 | 230×90×190/ 9.05×3.54×7.48 | 1.23 | 1.34 |
| GD28-0R7G-4 | | | | | |
| GD28-1R1G-4 | | | | | |
| GD28-1R5G-4 | B | 70×190×155/ 2.75×7.48×6.1 | 230×90×190/ 9.05×3.54×7.48 | 1.23 | 1.34 |
| GD28-2R2G-4 | | | | | |

| Product model | Frame | Outline dimensions W×H×D (mm/in) | Packaging dimensions W×H×D (mm/in) | Net weight (kg) | Gross weight (kg) |
|---------------|-------|-------------------------------------|--|-----------------------|-------------------------|
| GD28-003G-4 | | | | | |
| GD28-004G-4 | | | | | |
| GD28-5R5G-4 | C | 90×235×155/ 3.54×9.25×6.1 | 278×150×245/ 10.9×5.9×9.6 | 2.05 | 2.259 |
| GD28-7R5G-4 | | | | | |
| GD28-011G-4 | D | 130×250×185/ 5.11×9.84×7.28 | 325×190×235/ 12.8×7.5×9.3 | 3.55 | 4.05 |
| GD28-015G-4 | | | | | |
| GD28-018G-4 | E | 160×300×190/6.29 ×11.81×7.48 | 413×255×300/ 16.3×10×11.8 | 4.90 | 5.40 |
| GD28-022G-4 | | | | | |

 **Note:**

- The product frames are divided into A, B, C, D, and E.
- The difference between the weight in the table and the actual weight is $\leq 3\%$.

2.6 Product structure

| Warning | |
|---|--|
|  | <ul style="list-style-type: none"> • The Type-C port serves as a monitoring and debugging interface. • The external keypad cannot be used when the Type-C port is connected. |

Figure 2-1 Product structure



| No. | Component | No. | Component |
|-----|---|-----|----------------------------------|
| 1 | Input safety protection grounding terminal | 10 | RJ45 network port |
| 2 | EMC AC screw | 11 | Model bar code |
| 3 | Cover | 12 | Control board terminal |
| 4 | Signal grounding terminal (PE) | 13 | Nameplate |
| 5 | Output terminal functions | 14 | Expansion card interface |
| 6 | Output safety protection grounding terminal | 15 | Housing |
| 7 | VDR screw | 16 | Type-C interface (control board) |
| 8 | Input terminal functions | 17 | Cooling fan |
| 9 | Potentiometer knob | 18 | EMC DC clip |

Note: The positions of EMC AC screw, VDR screw, and EMC DC clip are not exactly the same for VFDs in different frames. For details, see Figure 4-1, Figure 4-2, and Figure 4-3.

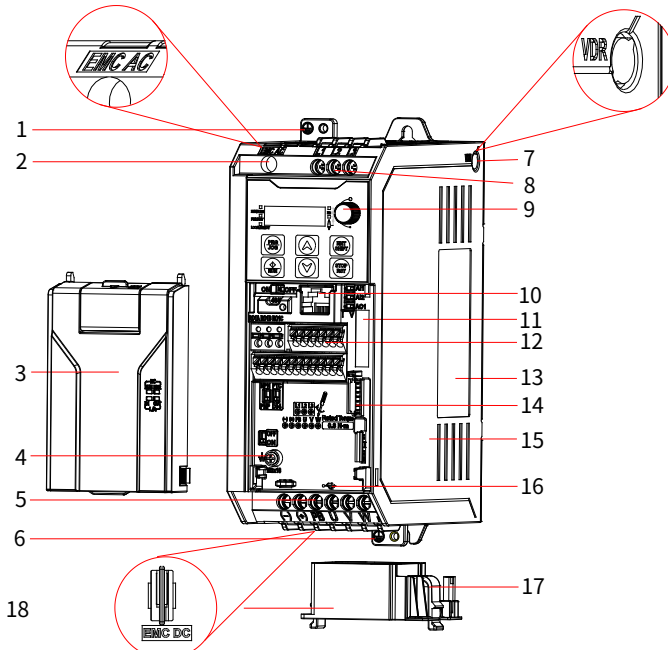
2.7 System configuration

When using the VFD to drive a motor to form a control system, various electrical devices need to be installed on the input and output sides of the VFD to ensure stable system running.

Figure 2-2 System composition

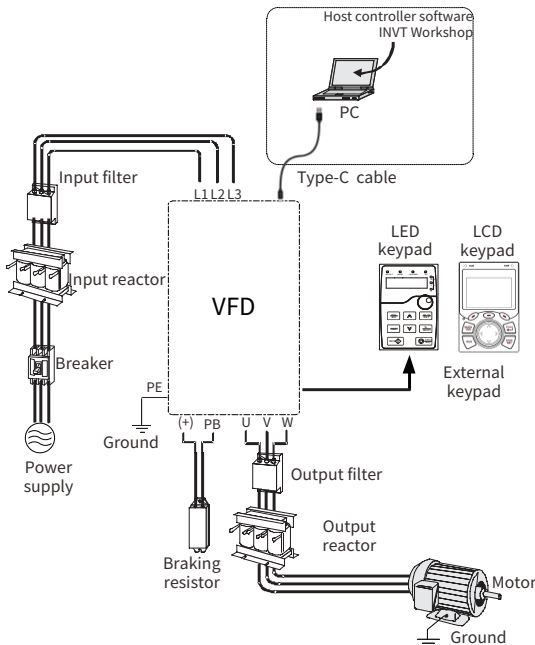









Table 2-1 System configuration

| Component | | Position | Description |
|---|---------------|---|---|
|  | Breaker | Between the power supply and the VFD input side | Device for electric shock prevention and protection against short-to-ground that may cause current leakage and fire. Select residual-current circuit breakers (RCCBs) that are applicable to VFDs and can restrict high-order harmonics, and of which the rated sensitive current for one VFD is larger than 30 mA. |
|  | Input Reactor | On the VFD input side | Accessories used to improve the power factor on the input side of the VFD, and thus restrict high-order harmonic currents. |

| Component | | Position | Description |
|---|--------------------------|--|--|
|  | Output Reactor | Between the VFD output side and the motor, and installed near the VFD. | (Optional) Accessory used to lengthen the valid transmission distance of the VFD, which effectively restricts the transient high voltage generated during the switch-on and switch-off of the IGBT module of the VFD. |
|  | Input Filter | On the VFD input side | (Optional) Input filter: Accessory that restricts the electromagnetic interference generated by the VFD and transmitted to the public grid through the power cable. Try to install the input filter near the input terminal side of the VFD. |
|  | Output Filter | Adjacent to the VFD output terminals | (Optional) Output filter: Accessory used to restrict interference generated in the wiring area on the output side of the VFD. All the product series can meet the conductivity and transmission requirements of IEC/EN 61800-3 C3 electrical drive systems. Optional external filters can be used to meet the conductivity and transmission requirements of IEC/EN 61800-3 C2 electrical drive systems. Note: Please comply with the technical requirements specified in the appendix of the manual for the assembly of motors, motor cables, and filters. |
|  | Braking resistor | Between the VFD main circuit terminals (+) and PB | Accessories used to consume the regenerative energy of the motor to reduce the DEC time. <ul style="list-style-type: none"> ● Braking unit: Already embedded (only external braking resistor required) ● Braking resistor: Optional and externally connected for all models |
|  | Host controller Software | Installed on the host controller for VFD management. | INVT Workshop software is used to configure and monitor the VFD. Its main functions include: <ul style="list-style-type: none"> ● Monitor multiple VFDs. ● Set and monitor function parameters; upload and download function parameters in batches. ● View the modified function codes, compare the default values, follow function codes, and search function codes |

| Component | | Position | Description |
|-----------|--|----------|---|
| | | | <ul style="list-style-type: none"> ● View and follow state parameters ● View the real-time faults and historical faults ● Display function codes in configuration mode ● Control the start/stop and forward/reverse running of the device ● View oscilloscope curve, save and playback waveform data, operate the waveform by cursor, and simulate waveform data. <p>You can visit our website at https://www.invt.com to download the software for free.</p> |

For details about optional part model selection, see Appendix E Peripheral accessories.

2.8 Quick startup

| Task | Reference |
|---|--|
| 1. Unpacking inspection. | See section 3.1 Unpacking inspection. |
| 2. Check whether the VFD connected load and power supply match. | See section 2.1 Product nameplate and model. |
| 3. Check the installation environment. | See section 3.2 Preparing. |
| 4. Install the VFD on the wall/in the cabinet. | See section 3.3 Installation. |
| 5. Wiring. | See chapter 4 Electrical installation. |
| 6. Commission the VFD. | See chapter 6 Commissioning. |

3 Mechanical installation

3.1 Unpacking inspection

After receiving the product, perform the following steps to ensure the product use safety.

■ Check the package

Before unpacking, check whether the product package is intact—whether the package is damaged, dampened, soaked, or deformed. After unpacking, check whether the interior surface of the packing box is abnormal, for example, in wet condition.

■ Check the machine and parts

After unpacking, check whether the equipment enclosure is damaged or cracked, whether the parts (including the VFD and manual) inside the packing box are complete, and whether the nameplate and label on the product body are consistent with the model ordered.





3.2 Preparing

Only trained and qualified professionals are allowed to carry out the operations mentioned in this chapter. Read the following installation preparation carefully before installation to ensure smooth installation and avoid personal injury or equipment damage.





| Warning | |
|--|---|
|  | <ul style="list-style-type: none"> ● Carry out operations according to instructions presented in section 1.4 Safety guidelines. Ensure the VFD power has been disconnected before installation. If the VFD has been powered on, disconnect the VFD and wait for at least the time designated on the VFD, and ensure the POWER indicator is off. ● The VFD installation must be designed and done according to applicable local laws and regulations. INVT does not assume any liability whatsoever for any VFD installation which breaches local laws or regulations. |

3.2.1 Installation environment and site

■ Environment requirements

| Environment | Requirement | |
|------------------------|---|---|
| Temperature |  | <ul style="list-style-type: none"> • -10~+50°C • There is no sudden temperature change. • When the VFD is installed in a closed space, such as control cabinet, use a cooling fan or air conditioner for temperature adjustment if necessary. • When the temperature is too low, if you want to use the VFD that has been idled for a long time, install an external heating device before the use to eliminate the freeze inside the VFD. Otherwise, the VFD may be damaged. |
| Relative humidity (RH) |  | <ul style="list-style-type: none"> • The relative humidity (RH) of the air is less than 95%, and there is no condensation. • The max. RH cannot exceed 60% in the environment where there are corrosive gases. |
| Altitude Height |  | <ul style="list-style-type: none"> • Lower than 1000m • When the altitude exceeds 1000m, derate by 1% for every increase of 100m. • When the altitude exceeds 3000m, consult our local dealer or office for details. |
| Vibration |  | Max. vibration ACC: 5.8m/s ² (0.6g) |

■ Site requirement

| Site | Requirement | |
|--------|---|---|
| Indoor |  | Without electromagnetic radiation sources and direct sunlight. ⚡ Note: The VFD must be installed in a clean and well-ventilated environment based on the housing IP rating. |
| |  | Without foreign objects such as oil mist, metal powder, conductive dust, and water. |
| |  | Without radioactive, corrosive, hazard, and combustible and explosive substances. ⚡ Note: Do not install the VFD onto combustible objects. |
| |  | With low salt content |

3.2.2 Installation direction

The VFD can be installed on a wall or in a cabinet, and it must be installed vertically. It cannot be installed in other directions such as horizontal (lying), transverse (lateral), or inverted.

Figure 3-1 Mounting direction

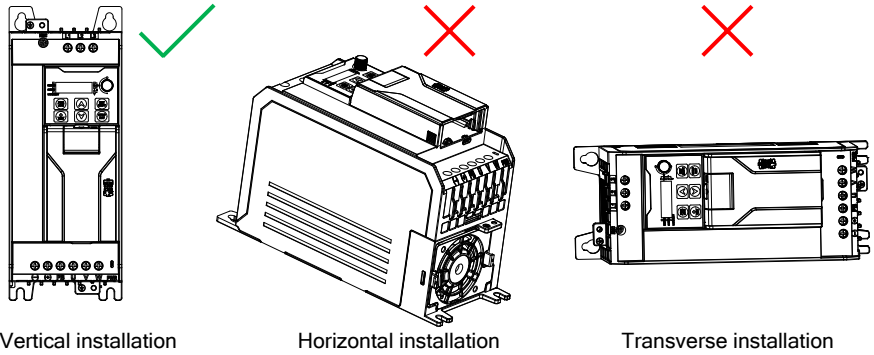

3.2.3 Installation space

3.2.3.1 Single VFD

Figure 3-2 Installation space diagram of single VFD

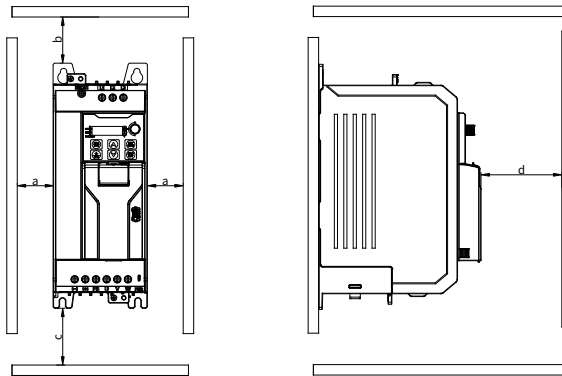

Table 3-1 Installation space dimensions of single VFD

| Frame | Dimensions (mm) | | | |
|---------------|-----------------|------|------|-----|
| | a | b | c | d |
| A, B, C, D, E | ≥40 | ≥100 | ≥100 | ≥40 |

3.2.3.2 Multiple VFDs

When installing multiple VFDs, you can install them in parallel. When you install VFDs in different sizes, align the top of each VFD before installation for the convenience of future maintenance.

Figure 3-3 Installation space diagram of multiple VFDs

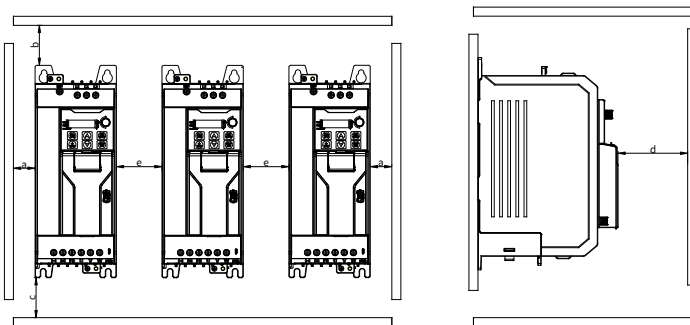

Note: The ambient temperature for side-by-side installation must not exceed 40°C.

Table 3-2 Installation space dimensions of multiple VFDs

| Frame | Dimensions (mm) | | | | |
|---------------|-----------------|------|------|-----|---|
| | a | b | c | d | e |
| A, B, C, D, E | ≥40 | ≥100 | ≥100 | ≥40 | ≥30 |
| | | | | | =0 (Heavy-load: Ambient environment ≤40°C) |

3.3 Installation and uninstallation

The VFD installation methods vary with the VFD frames. Please choose the appropriate installation method from the following table based on the specific model and the applicable environment. (✓ indicates the installation method that can be selected.)

Table 3-3 Installation method selection

| Frame | Mounting method | | |
|-------|-----------------|-------------------|-----------------|
| | Wall mounting | DIN rail mounting | Flange mounting |
| A | ✓ | ✓ | - |
| B | ✓ | ✓ | - |
| C | ✓ | - | ✓ |
| D | ✓ | - | ✓ |
| E | ✓ | - | ✓ |

Note: When selecting the DIN rail mounting method for the models in frame A or B, you must select a rail mounting bracket. For details about the mounting bracket sizes and ordering codes, see section E.3.5 DIN rail mounting bracket. The flange mounting plate must be used for flange mounting of a VFD in frame C, D, or E.

3.3.1 Installation

3.3.1.1 Wall mounting

The wall mounting procedure is as follows:

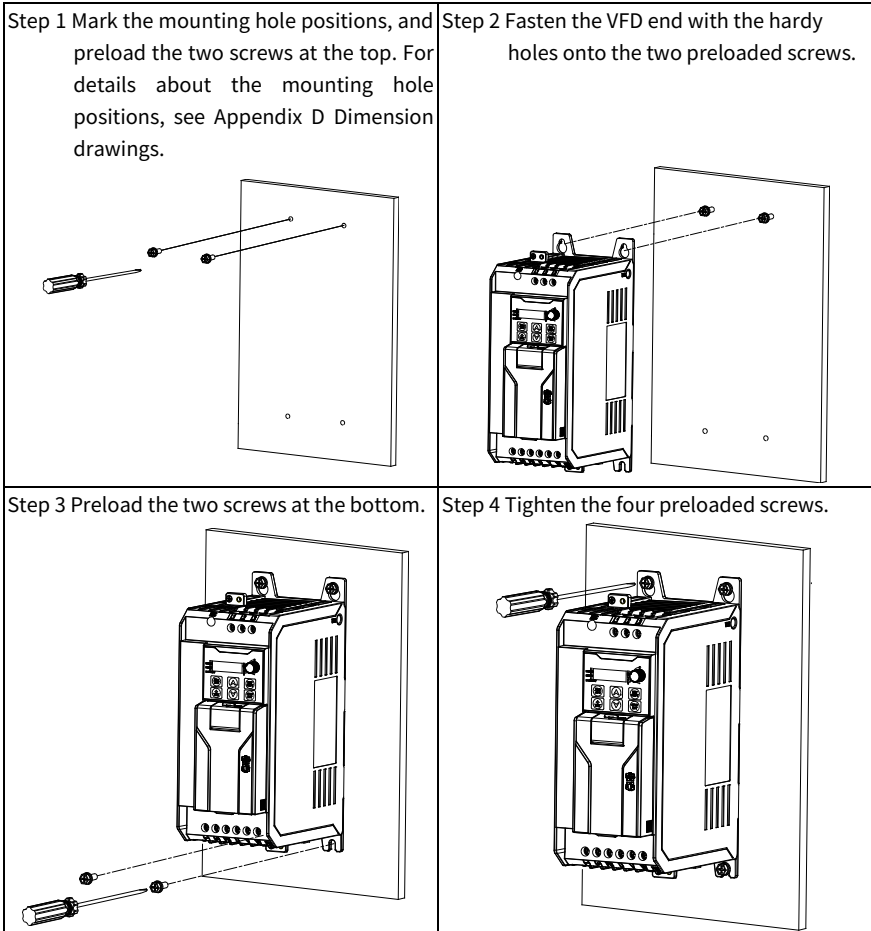

3.3.1.2 DIN rail mounting

The mounting procedure is as follows:

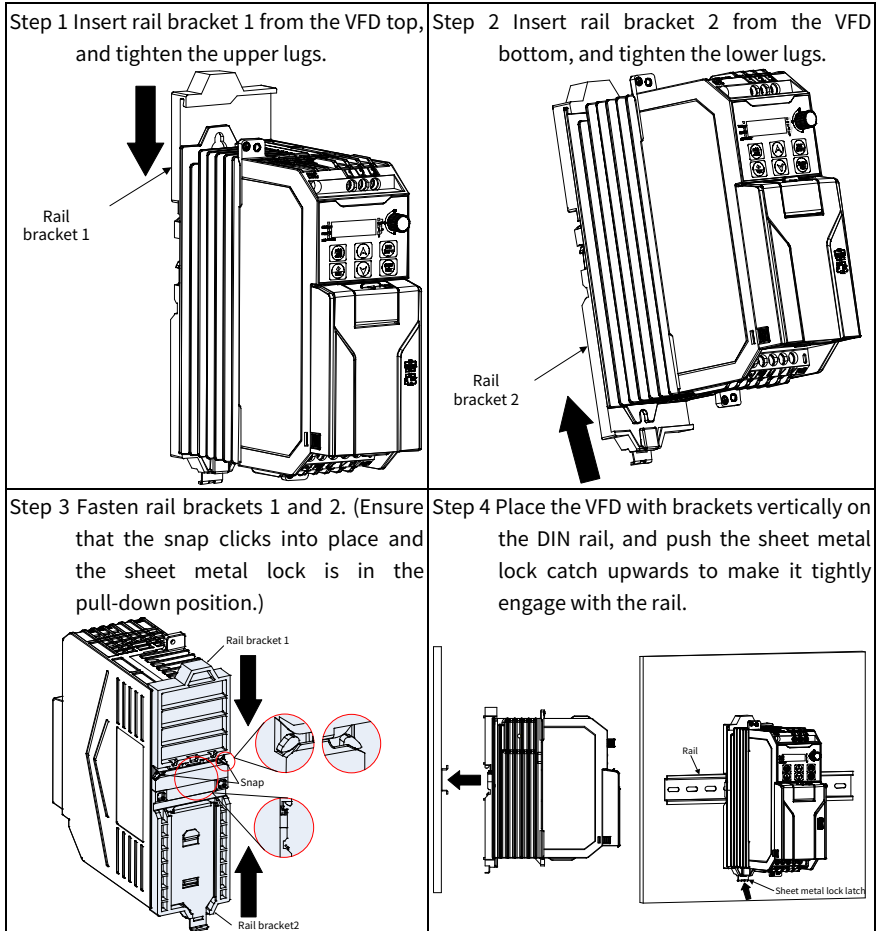

3.3.1.3 Flange mounting

The mounting procedure is as follows:

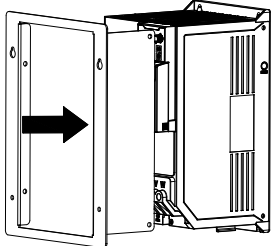
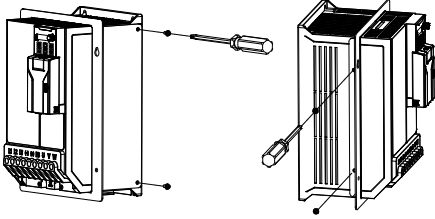
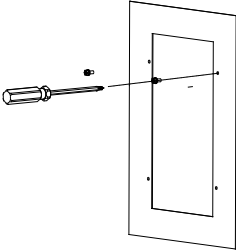
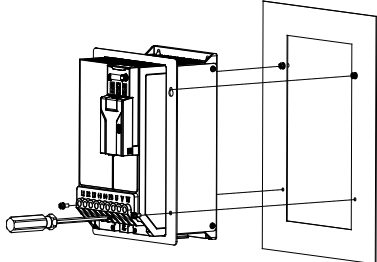
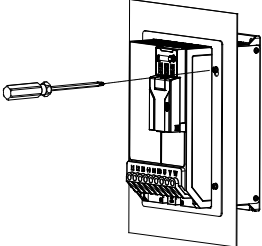
| | |
|--|---|
| <p>Step 1 Insert the flange mounting bracket vertically from the front of the machine.</p>  | <p>Step 2 Install the four M4 screws on the side of the machine.</p>  |
| <p>Step 3 Pre-install two screws on the mounting surface.</p>  | <p>Step 4 Align the keyhole slots on the top of the flange mounting bracket with the pre-installed screws, and then install the two lower screws.</p>  |
| <p>Step 5 Tighten and check all four screws to complete the installation.</p>  | |

3.3.2 Disassembly

3.3.2.1 DIN rail dismantling

The dismantling procedure is as follows:

Step 1 Use a tool to pull out the sheet metal lock catch downwards until it is fixed, and take out the VFD with the rail bracket from the DIN rail.

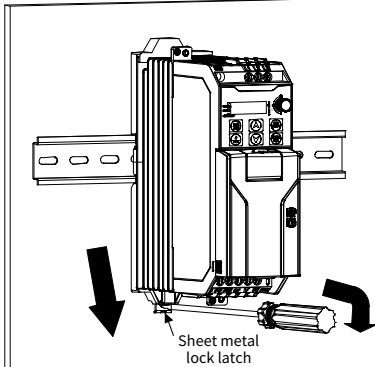

Step 2 Insert a flathead screwdriver into the snap slot and rotate it 90 degrees to release the snap on that side. Repeat the same method to remove the snap on the other side.

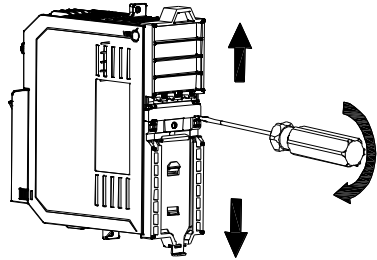

3.3.2.2 Cover dismounting

You need to remove the VFD cover for main circuit and control circuit wiring.

The disassembly procedure is as follows:

Step 1 Press the elastic snaps on both sides of the bottom of the cover, and lift them up with force until the snaps detach from the slot.

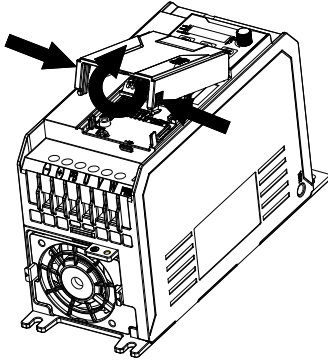

Step 2 Lift the cover and pull it out in tilted way.

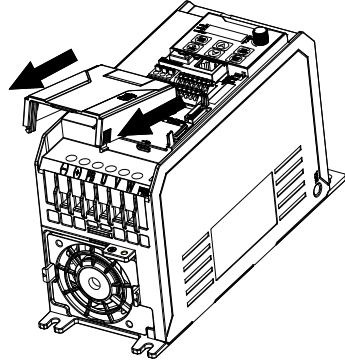

4 Electrical installation

4.1 Insulation inspection

Do not perform any voltage endurance or insulation resistance tests, such as high-voltage insulation tests or using a megohmmeter to measure the insulation resistance, on the VFD or its components. Insulation and voltage endurance tests have been performed between the main circuit and housing of each VFD before delivery. In addition, voltage limiting circuits that can automatically cut off the test voltage are configured inside the VFDs. If you need to conduct insulation resistance testing on the VFD, please contact us.

Note: Before conducting insulation resistance testing on input and output power cables, remove the cable connection terminals from the VFD.

■ Input power cable

Check the insulation conditions of the input power cable of a VFD according to the local regulations before connecting it.

■ Motor cable

Ensure that the motor cable is connected to the motor, and then remove the motor cable from the U, V, and W output terminals of the VFD. Use a megohmmeter of 500V DC to measure the insulation resistance between each phase conductor and the protection grounding conductor. For details about the insulation resistance of the motor, see the description provided by the manufacturer.

Note: If the motor interior is damp, the insulation resistance will decrease. If moisture is suspected, dry and re-measure the motor.

4.2 Checking compatible grounding systems

The VFD has been equipped with the embedded EMC filter as standard and therefore it can be installed on symmetric grounding systems and asymmetric grounding systems. When the VFD is used in an asymmetric grounding system, the EMC screws and clip (namely, the EMC AC screw, EMC DC screw, and EMC DC clip) must be removed to avoid the connection between the VFD internal EMC filter capacitor and the grounding potential, which may cause the VFD tripping or damage. The VFD supports the TN-S, TT, and IT grounding systems.

4.2.1 EMC filter grounding capacitor

The VFD with an internal EMC filter can be installed on a TN-S system with a symmetrical earth ground. If the VFD is installed to another grounding system, it may be necessary to

disconnect the EMC filter and the voltage dependent resistor (VDR). See sections 4.2.3 When to disconnect the EMC filter or VDR: TN-S, IT, corner-grounded delta and midpoint-grounded delta systems and 4.2.4 Guidelines for installing the VFD in TT systems.

| Warning | |
|---|--|
|  | Do not install a VFD with an EMC filter on a system that is not suitable for the filter. This can cause a hazard or damage to the VFD. |

Note: When the internal EMC filter is disconnected, the EMC compatibility of the VFD will be significantly reduced and will not meet the EMC compatibility motor cable length requirements in section B.5.2 Motor cable length for EMC.

4.2.2 Ground-to-phase VDR

Most VFDs are designed to operate on three-phase power supply systems with symmetric line voltages. To meet surge immunity requirements, these VFDs are equipped with VDRs, which provide voltage surge protection as well as phase-to-phase and phase-to-ground protection. The VDR circuit is designed only for surge suppression (transient line protection) and is not intended for continuous operation.

For ungrounded supply systems, the phase-to-ground VDR can provide a continuous current path to ground. Exceeding the published phase-to-phase, phase-to-ground voltage or energy ratings may damage the VDR.

Standard VFDs with VDRs can be installed in symmetrically grounded TN-S systems. If the VFD is installed to another grounding system, it may be necessary to disconnect the the VDR. See sections 4.2.3 When to disconnect the EMC filter or VDR: TN-S, IT, corner-grounded delta and midpoint-grounded delta systems and 4.2.4 Guidelines for installing the VFD in TT systems.

| Warning | |
|---|---|
|  | Do not connect the phase-to-ground VDR to a system that is not suitable for the VDR when installing the VFD. Otherwise, the VDR circuit may be damaged. |

4.2.3 When to disconnect the EMC filter or VDR: TN-S, IT, corner-grounded delta and midpoint-grounded delta systems

The requirements for disconnecting EMC filters and VDRs, as well as additional requirements for different power systems are shown in the following.

| | | | |
|--------------|---|---|--|
| Frame | Symmetrical grounding TN-S system, also known as grounding Y system (A) | Corner-grounded delta (B1) and midpoint-grounded delta (B2) systems $\leq 600V$ | IT system (floating ground or high resistance grounding [$>30\Omega$]) (C) |
| A, B | Do not disconnect the EMC AC screw, EMC DC clip, and VDR screw. | Disconnect the EMC AC screw, EMC DC clip, and VDR screw. | Disconnect the EMC AC screw, EMC DC clip, and VDR screw. |
| C | Do not disconnect the EMC AC or VDR screw. | Disconnect the EMC screw and VDR screw. | Disconnect the EMC screw and VDR screw. |
| D, E | Do not disconnect the EMC AC screw, EMC DC screw, and VDR screw. | Disconnect the EMC AC screw, EMC DC screw, and VDR screw. | Disconnect the EMC AC screw, EMC DC screw, and VDR screw. |

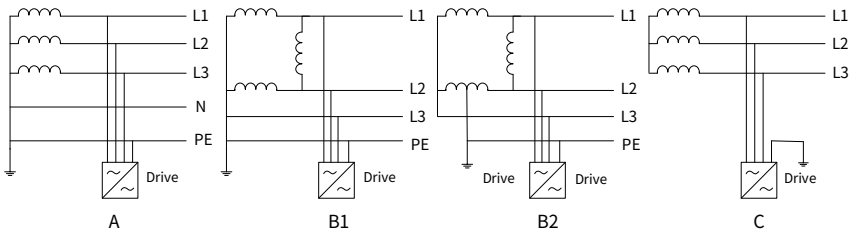

Note: These are the EMC filter and VDR screws in the VFDs in different outline dimensions.

| Frame | EMC filter screw/clip | VDR screw |
|-------------|--|-----------|
| A, B | EMC AC screw and EMC DC clip | VDR |
| C | EMC AC screw | VDR |
| D, E | Two EMC screws (including EMC AC and EMC DC) | VDR |

4.2.4 Guidelines for installing the VFD in TT systems

The VFD can be installed on the TT system under the following conditions:

1. A residual current protection device has been installed in the power supply system.
2. These screws have been disconnected. Otherwise, the leakage current from the EMC filter, VDR, and capacitor can cause the residual current protection device to trip.

| Frame | EMC filter screw | VDR screw |
|-------|--|-----------|
| A, B | EMC AC screw, EMC DC clip | VDR |
| C | EMC AC screw | VDR |
| D, E | Two EMC screws (including EMC AC and EMC DC) | VDR |

Note:

- The VFD is not compliant with the EMC classification if the EMC filter screw is disconnected.
- The VFD does not guarantee the proper operation of its internal ground leakage detector.
- In large systems, the leakage protection device may trip unexpectedly.

4.2.5 Identifying grid grounding systems

| Warning | |
|----------------|--|
| | Only qualified professionals are allowed to carry out the operations mentioned in this section. Depending on the installation location, this work can even be classified as live work. Only electrical professionals certified for the job should proceed with the work. Comply with local regulations. Ignoring these instructions could result in injury or death. |

To determine the grounding system, check the power transformer connections. See the applicable electrical drawings for the building. Otherwise, measure these voltages at the switchboard and see the table to identify the grounding system type.

Input line phase-to-phase voltage (U_{L-L})

Input line L1 to-ground voltage (U_{L1-G})

Input line L2 to-ground voltage (U_{L2-G})

Input line L3 to-ground voltage (U_{L3-G})

The following table shows the relationship between line-to-ground voltage and line-to-line voltage for each grounding system.

| U_{L-L} | U_{L1-G} | U_{L2-G} | U_{L3-G} | Power system type |
|-----------|-------------------------|-------------------------|-------------------------|---|
| X | 0.58 X | 0.58 X | 0.58 X | Symmetric grounding system (TN-S system) |
| X | 1.0 X | 1.0 X | 0 | Corner-grounded delta system (asymmetric) |
| X | 0.866 X | 0.5 X | 0.5 X | Neutral-grounded delta system (asymmetrical) |
| X | Level changes over time | Level changes over time | Level changes over time | IT system (floating or high resistance grounding [$>30\Omega$]) asymmetric |
| X | Level changes over time | Level changes over time | Level changes over time | TT system (protective earth connection of electrical equipment is provided by local connection. A separate protective earth connection is installed at the generator) |

4.2.6 Disconnecting the internal EMC filter or VDR, for frames A to E

To disconnect the internal EMC filter or VDR, if necessary, proceed as follows:

Turn off the power supply to the VFD.

To disconnect the internal EMC filter, remove the EMC screw/clip (see earlier mentioned EMC filter and VDR screws for VFDs in different frames for details).

To disconnect the VDR, remove the VDR screw.

For the models with embedded EMC filter, the common-mode capacitor circuit is grounded to the heat sink through EMC screw, forming a loop path for high-frequency noise and releasing high-frequency interference; if leakage protection is applied during startup when a leakage circuit breaker has been configured, disconnect the EMC screw/clip (see section 4.2.3 When to disconnect the EMC filter or VDR: TN-S, IT, corner-grounded delta and midpoint-grounded delta systems).

Figure 4-1 EMC screw positions (for frames A and B)

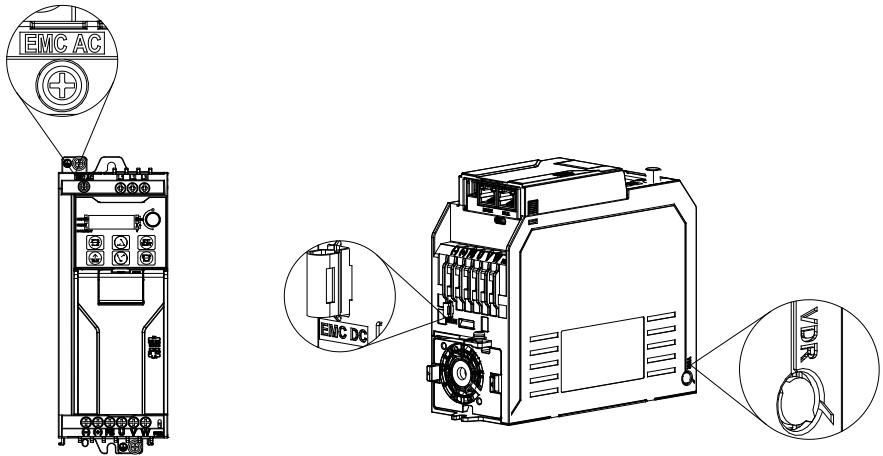

Figure 4-2 EMC screw positions (for frame C)

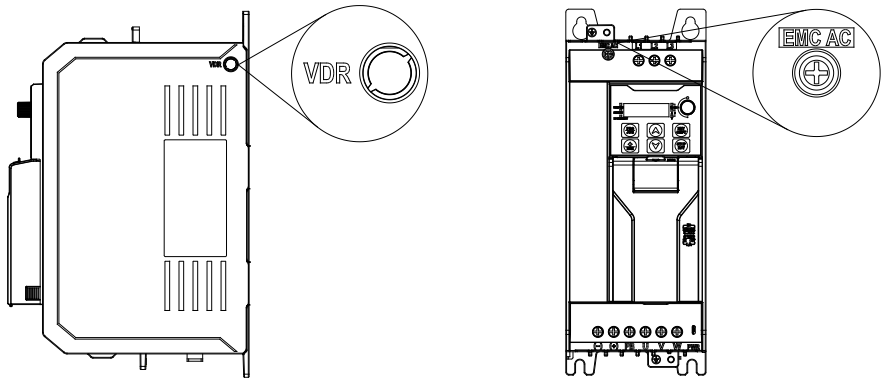
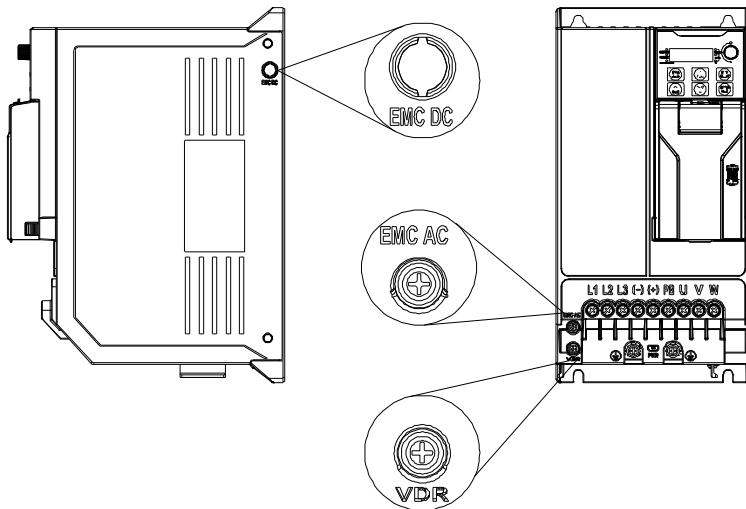

Figure 4-3 EMC screw positions (for frames D and E)



Note:

- Do not remove EMC screws when the VFD is powered on.
- Disconnecting EMC screws will reduce the VFD electromagnetic compatibility, which may cause the failure to meet the EMC specification requirements.
- For the models with embedded EMC filter, the common-mode capacitor circuit is grounded to the heat sink through EMC screws, forming a loop path for high-frequency noise and releasing high-frequency interference; if leakage protection is applied during startup when a leakage circuit breaker has been configured, disconnect the EMC screws.

4.3 Cable selection and routing

4.3.1 Cable selection

■ Power cable

Power cables mainly include input power cables and motor cables. Comply with local regulations to select cables.

To meet the EMC requirements stipulated in the CE standards, it is recommended to use symmetrical shielded cables as input motor cables and power cables, as shown in Figure 4-4. Compared with four-core cables, symmetrical shielded cables can reduce electromagnetic radiation as well as the current and loss of the motor cables.

Figure 4-4 Symmetrical shielded cable and four-core cable

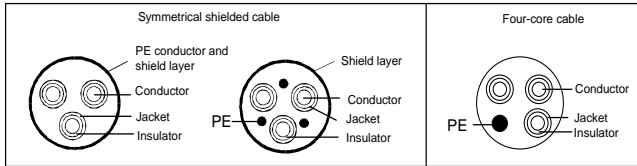
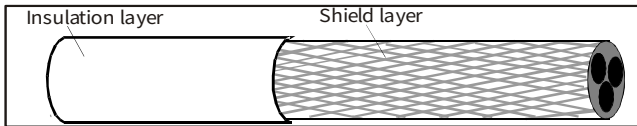

Figure 4-5 Cable cross section

**Note:**

- The input power cables and motor cables must be able to carry the corresponding load currents.
- Figure 4-5 shows the minimum requirement on the motor cable of VFD. The cable contains a layer of spiral-shaped copper strips. The denser the shield layer is, the more effectively the electromagnetic interference is restricted.
- The cable conductor temperature limit is 70 °C. If you use a cable with the conductor temperature limit of 90 °C, the cable must comply with relevant national standards and specifications.
- If the electrical conductivity of the motor cable shield layer does not meet the requirements, a separate PE conductor must be used.
- The cross-sectional area of the shielded cables must be the same as that of the phase conductors if the cable and conductor are made of materials of the same type.
- To effectively restrict the emission and conduction of radio frequency (RF) interference, the conductivity of the shielded cable must be at least 1/10 of the conductivity of the phase conductor.
- This requirement can be well met by a copper or aluminum shield layer.

Control cable

Control cables mainly include analog signal control cables and digital signal control cables. Analog signal control cables use twisted double shielded cables with a separate shielded twisted pair for each signal and different ground wires for different analog signals. For digital signal control cables, a double-shielded cable is preferred, but single-shielded or unshielded twisted pairs can also be used. For details, see section E.1.2 Control cable.

4.3.2 Cable arrangement

The cable routing and routing distance are shown in Figure 4-6.

Figure 4-6 Cable routing distance

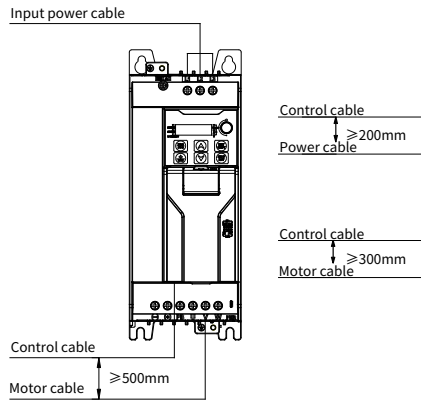

Note:

- Motor cables must be arranged away from other cables. The du/dt of the VFD output may increase electromagnetic interference on other cables.
- Motor cables cannot be routed with other cables in parallel for long distances.
- If the control cable and power cable must cross each other, ensure that the angle between them is 90° .
- Motor cables of multiple VFDs can be routed in parallel. It is recommended to route motor cables, input power cables, and control cables in separate cable trays.
- The cable trays must be connected properly and well grounded.
- Do not route other additional cables through the VFD.

4.4 Main circuit wiring

4.4.1 Main circuit wiring

Figure 4-7 Main circuit wiring diagram

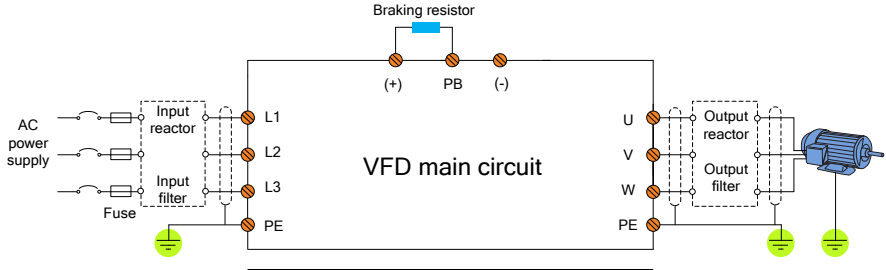

Note: The fuse, input reactor, input filter, output reactor, and output filter are optional parts. For details, see Appendix E Peripheral accessories.

4.4.2 Main circuit terminals

Figure 4-8 Main circuit terminal diagram for VFDs in frame A

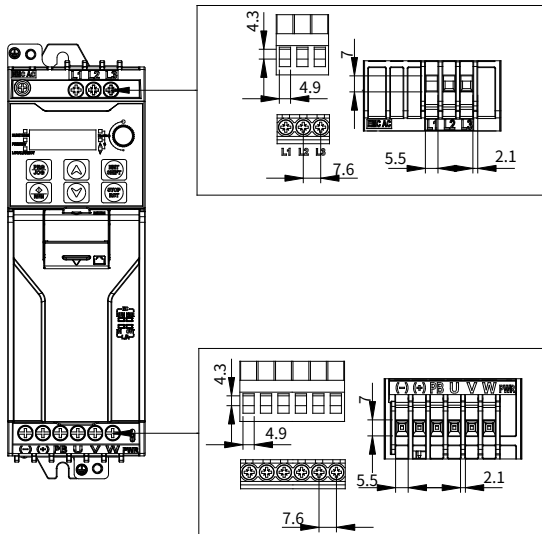

Figure 4-9 Main circuit terminal diagram for VFDs in frame B

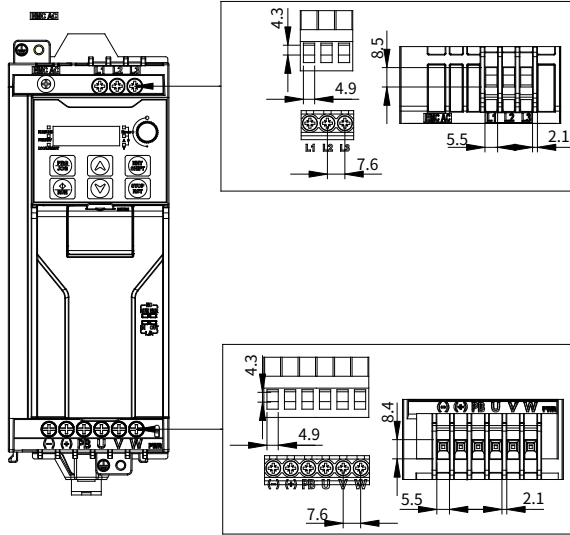

Figure 4-10 Main circuit terminal diagram for VFDs in frame C

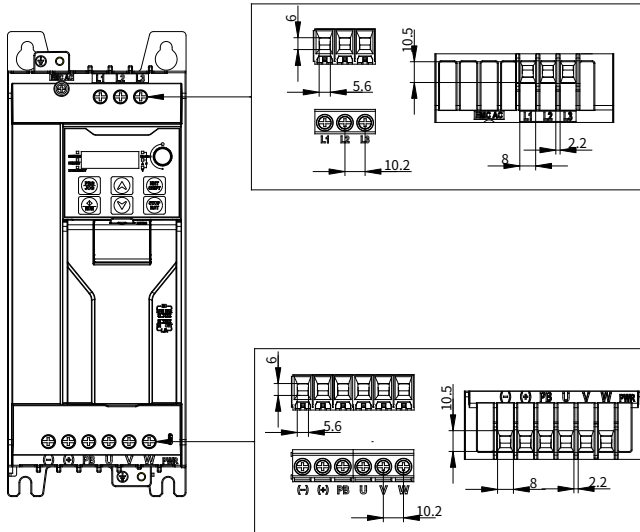

Figure 4-11 Main circuit terminal diagram for VFDs in frame D

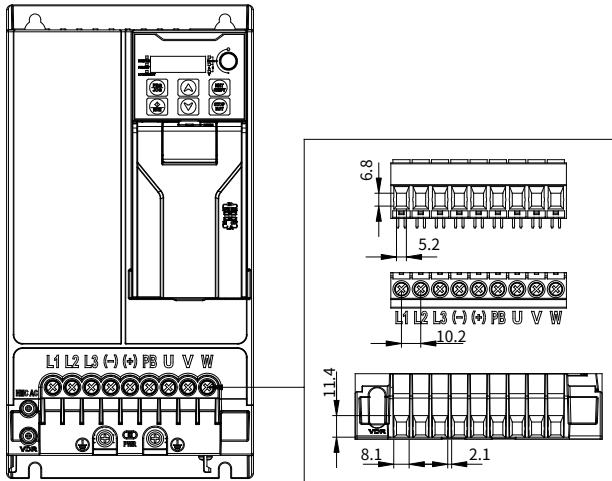

Figure 4-12 Main circuit terminal diagram for VFDs in frame E

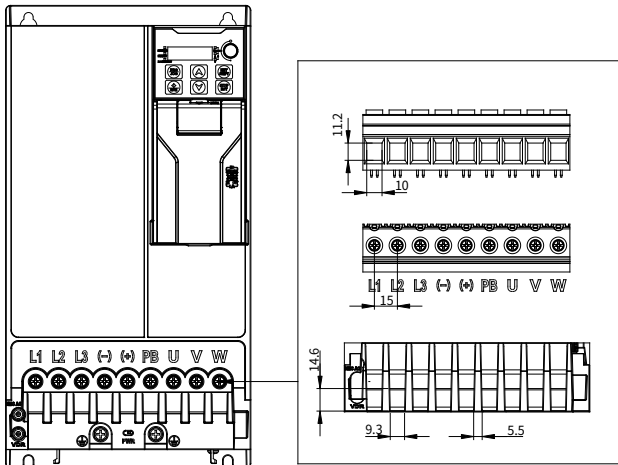

Table 4-1 Main circuit terminal definition

| Terminal | Function |
|------------------------|---|
| L1, L2, L3 (L1, L2) | 3PH (or 1PH) AC input terminals, connected to the grid |
| U, V, W | 3PH AC output terminals, connected to the motor usually |
| (+) | (+) and (-) connect to the shared DC bus terminals. |

| Terminal | Function |
|----------|--|
| (-) | PB and (+) connect to external braking resistor terminal |
| PB | |
| ⊕ | PE terminal. The PE terminals of each machine must be grounded reliably. |

Note: It is recommended to use a symmetrical motor cable. Please ground the grounding conductors in the motor cable at the VFD end and at the motor end.

4.4.3 Wiring procedure

Step 1 Connect the yellow and green grounding line of the input power cable to the VFD grounding terminal ⊕, connect the 3PH input cable to the L1, L2, and L3 terminals, and tighten up.

Figure 4-13 Wiring diagram of input power cables

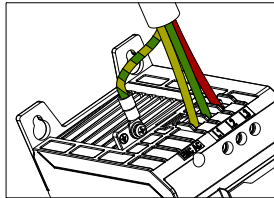

Step 2 Connect the yellow and green grounding line of the motor cable to the VFD PE terminal, connect the motor 3PH cable to the U, V and W terminals, and tighten up.

Figure 4-14 Wiring diagram of motor cables

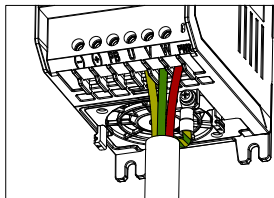

Step 3 Connect optional parts such as the braking resistor that carries cables to designated positions. For details, see section 4.3.1 Cable selection.

Step 4 Fasten all the cables outside the VFD mechanically if allowed.

Figure 4-15 Screw installation diagram

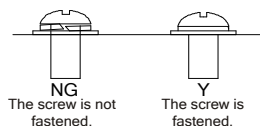

4.5 Control circuit wiring

4.5.1 Control circuit wiring

Figure 4-16 Control circuit wiring

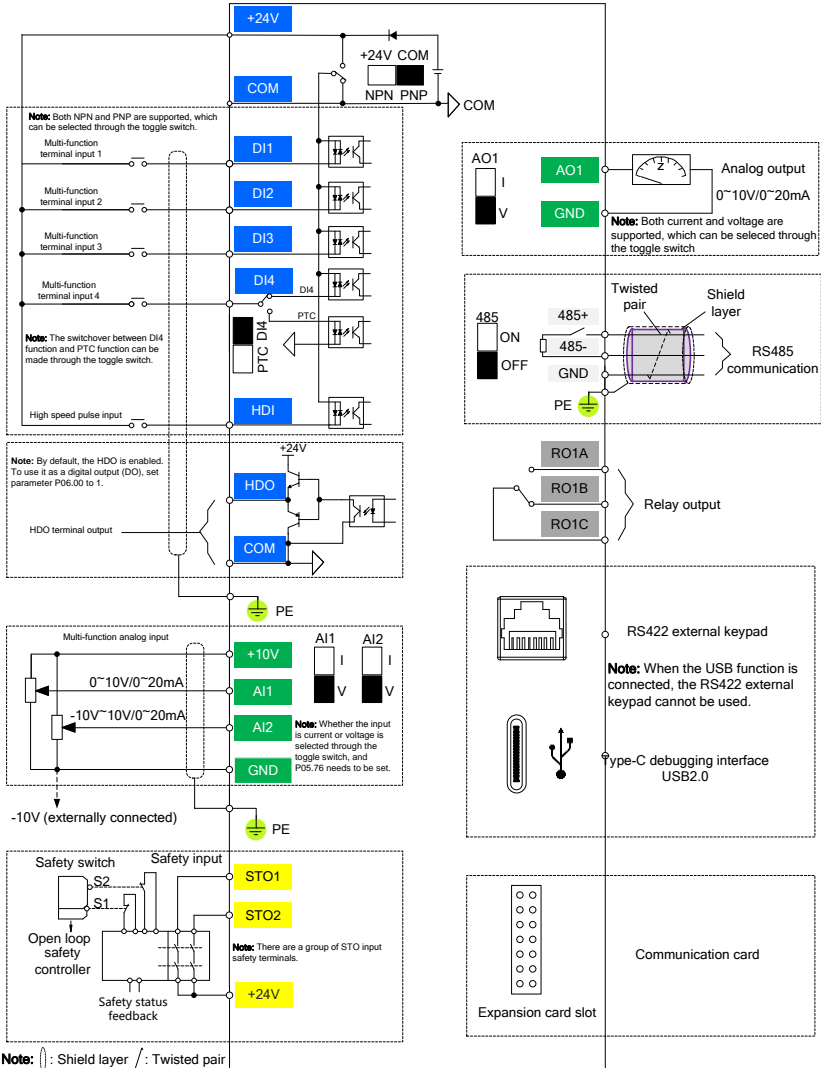

4.5.2 Control circuit terminals

Figure 4-17 Control circuit terminals

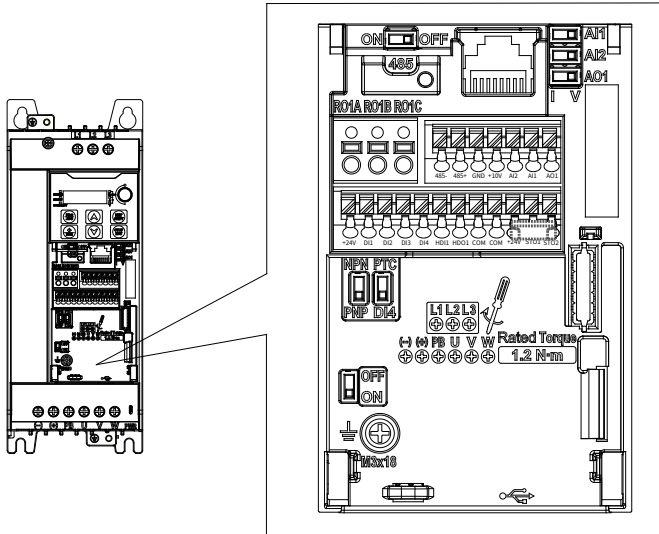

| Terminal | Function |
|----------|--|
| +10V | Locally provided +10V power supply. Max. output current: 50mA. |
| GND | Power supply reference ground |
| AI1 | Input range: 0–10V/0–20mA Input impedance: 33kΩ for voltage input or 250Ω for current input Whether the input is current or voltage is selected through the toggle switch AI1 (I/V), and the function code P05.76 also needs to be set accordingly. Accuracy: Full-scale accuracy of 1% |
| AI2 | Input range: 0–10V/0–20mA Input impedance: 33kΩ for voltage input or 250Ω for current input |

| Terminal | Function |
|---------------|---|
| | Whether the input is current or voltage is selected through the toggle switch AI1 (I/V), and the function code P05.76 also needs to be set accordingly. Accuracy: Full-scale accuracy of 1% |
| AO1 | Output range: 0–10V/0–20mA Whether the output is current or voltage is selected through the toggle switch AO1 (I/V). Accuracy: Full-scale accuracy of 1% |
| RO1A | Relay output. RO1A: NO; RO1B: NC; RO1C: common Contact capacity: 3A/AC 250V, 1A/DC 30V |
| RO1B | |
| RO1C | |
| HDO1 | Switch capacity: 50mA/30V Output frequency range: 0–50kHz When P06.00=1, it can be configured as normal DO terminal, with the push-pull output of 0V/24V, and the external power supply cannot be greater than 24V. |
| 485+ | RS485 differential signal communication port. Use shielded twisted pairs for standard RS485 communication interfaces. You can determine whether to connect the 120Ω terminal matching resistor of RS485 communication through the toggle switch 485(ON/OFF). |
| 485- | |
| Type-C | Type-C interface, which can be directly connected to a PC, using Modbus RTU as the communication protocol. When the VFD is not connected to the main power supply, it can be used to modify, save, import, and export parameters; when the VFD is connected to the main power supply, it can be used to control the VFD operation and monitor its running parameters. |
| +24V | User power supply provided by the VFD. Max. output current: 100mA It can be used as an external NPN mode power input for the DI terminal (the switch must be turned to the NPN position). |
| COM | +24V digital reference ground |
| DI1–DI4 (PTC) | DI1–DI4 digital input Effective input high level range: 10–30V Effective input low level range: 0–5V Max. input frequency: 1kHz Programmable digital input terminals, the functions of which can be set through the related parameters Whether the NPN or PNP mode is used can be selected through the toggle switch, and the connection to external power is supported. PTC function: DI4 can be configured with PTC overtemperature protection, |

| Terminal | Function |
|---|--|
| | which can be enabled through P05.04 and toggle switch setting. Overtemperature resistance: 3.6kΩ. Recovery resistance: 1.5kΩ. |
| HDI1 | It can act as a digital input channel, in addition to high frequency pulse input channel. It supports the switchover between NPN and PNP. Max. input frequency: 50kHz Duty ratio: 30%–70% |
| +24V–STO1 | Safe torque off (STO) redundant input, connected to the external NC contact. |
| +24V–STO2 | When the contact opens, STO acts and the VFD stops output. The safety input signal cable uses the shielded cable and the length is controlled within 25m. The STO1 and STO2 terminals are short connected to +24V by default. Remove the jumper from the terminals before using the STO function. |
| Communication expansion card terminals | |
| +24E | An external 24V connection can be used for communication debugging. |
| COM | |
| EC IN | Supported bus types: PROFINET, EtherCAT, EtherNet IP, and Modbus TCP EtherCAT can be only used in the IN port, while the other three protocols do not distinguish the direction. |
| EC OUT | Supported bus types: PROFINET, EtherCAT, EtherNet IP, and Modbus TCP EtherCAT can be only used in the OUT port, while the other three protocols do not distinguish the direction. |

4.5.3 Input/output signal wiring

4.5.3.1 Digital input/output signal wiring

■ Digital input signal wiring

The DI1–DI4 terminals of the VFD support NPN (sinking)/PNP (sourcing) connection, and the factory default connection is PNP (sourcing). External power wiring is supported.

Figure 4-18 NPN (sinking) wiring

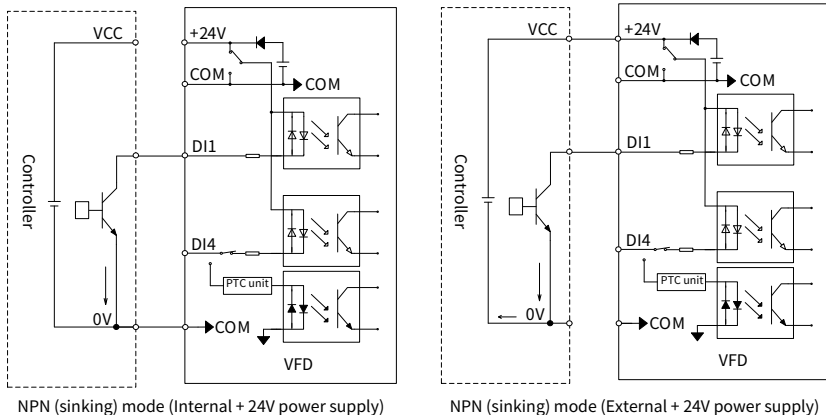
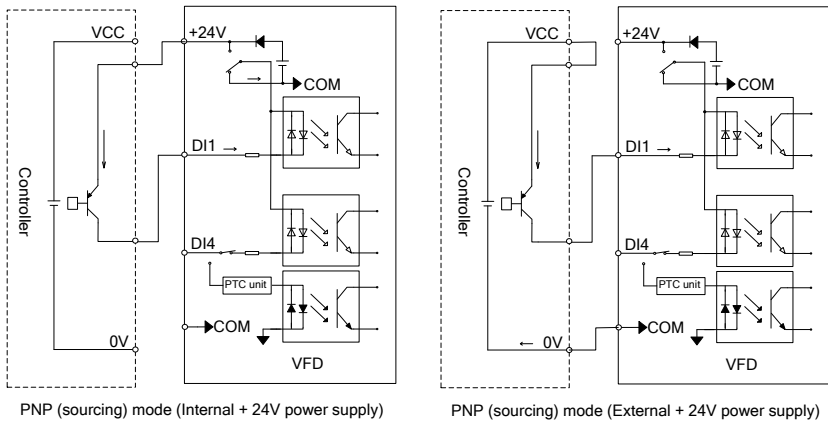

Figure 4-19 PNP (sourcing) wiring



■ Digital output signal wiring

HDO1 can act as a digital input channel, in addition to high frequency pulse input channel. P06.00=1 can be configured as a DO output, default NPN output, reversed to PNP output by P06.09 polarity.

When P06.00=1, it can be configured as normal DO terminal. NPN output is used by default, which can be reversed to PNP output by setting P06.09.

Figure 4-20 HDO1 terminal wiring

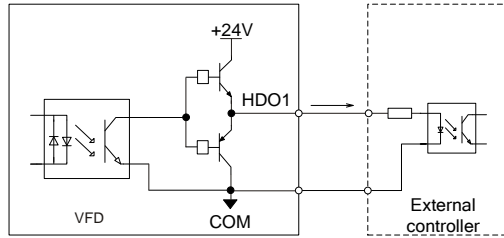

PNP output wiring

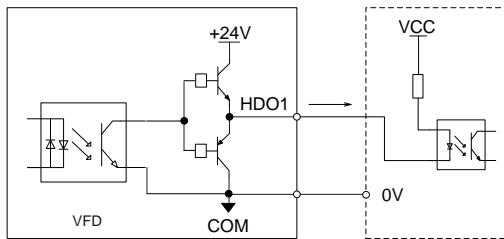

NPN output wiring

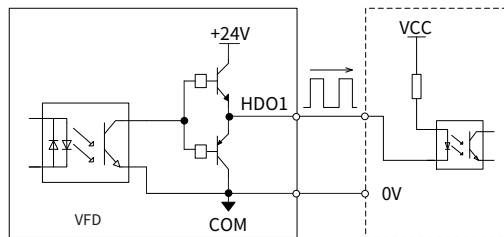
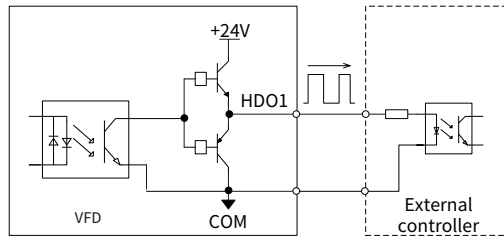

High-speed pulse output wiring

Note: When HDO1 uses PNP output, ensure that the total current of the DO output at

24V and the +24V control terminal does not exceed 100mA.

4.5.3.2 Analog input signal wiring

When the analog input terminal is connected to a weak signal, it is easily interfered by external noise. Therefore, shielded twisted pair cables are generally used, and the wiring distance should be within 20m. The lead line of the shield layer should be as short as possible and needs to be fixed to the VFD signal grounding \oplus with screws, as shown in Figure 4-21.

Figure 4-21 Analog input terminal wiring

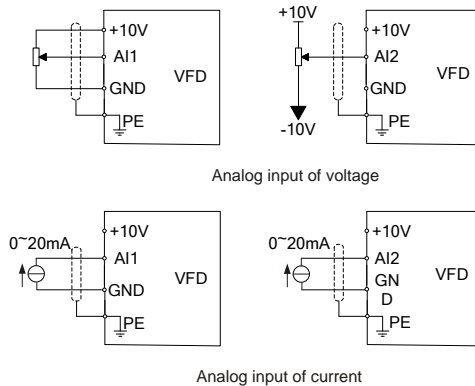
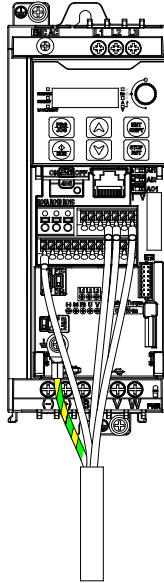
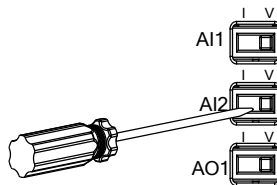

Figure 4-22 PE shield layer wiring



Note:

- When selecting current signal input for AI1 or AI2, use the screwdriver to turn the AI1 or AI2 toggle switch to the "I" side.
- When selecting current signal output for AO1, use the screwdriver to turn the AO1 toggle switch to the "I" side.



In some cases where the analog signal is severely disturbed, a filtering capacitor or magnetic ring needs to be installed on the analog signal source side. At least 3 turns are required to pass through the same phase.

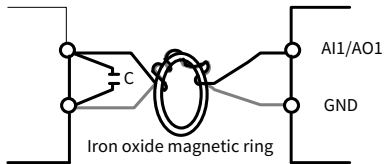

4.5.3.3 Relay output wiring

Since inductive loads (relays, contactors, and motors) can cause voltage transients when the power is off, it is necessary to add protective devices such as VDRs or diodes close to the inductive load ends. Do not add protective devices at the relay output ends.

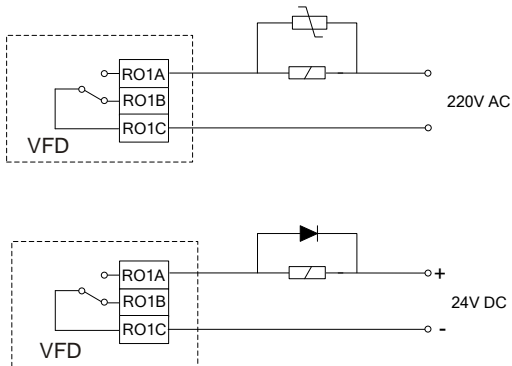

4.6 Power distribution protection

| Warning | |
|---------|---|
| | Do not connect any power source to the VFD output terminals U, V and W. The voltage applied to the motor cable may cause permanent damage to the VFD. |

■ **Power cable and VFD protection**

In case of short circuit, the fuse protects input power cables to avoid damage to the VFD; if internal short-circuit occurs to the VFD, it can protect neighboring equipment from being damaged. Figure 4-23 shows the wiring.

Figure 4-23 Fuse configuration

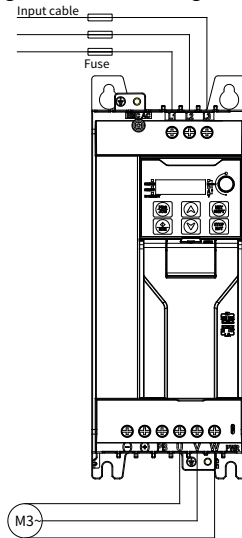

Note: Select the fuse according to section E.2 Breaker, fuse, and electromagnetic contactor.

■ Motor and motor cable short-circuit protection

If the motor cable is selected based on VFD rated current, the VFD is able to protect the motor cable and motor without other protective devices during short circuit.

Note: If the VFD is connected to multiple motors, use a separated thermal overload switch or breaker to protect the cable and motor, which may require the fuse to cut off the short circuit current.

■ Motor thermal overload protection

Once overload is detected, the power supply must be cut off. The VFD is equipped with the motor thermal overload protection function, which can block output and cut off the current (if necessary) to protect the motor.

■ Bypass connection protection

In some critical scenarios, the power/variable frequency conversion circuit needs to be configured to ensure proper operation of the system when a fault occurs to the VFD.

In some special scenarios, such as in soft startup, power-frequency running is directly performed after the startup, which requires bypass connection.

If VFD status needs to be switched frequently, you can use the switch which carries mechanical interlock or a contactor to ensure motor terminals are not connected to input power cables and VFD output ends simultaneously.

5 Keypad operation guidelines

5.1 Keypad introduction

The VFD is embedded with a LED keypad as a standard configuration part. You can use the keypad to control the start and stop, read status data, and set parameters of the VFD. You can also choose an external LED keypad or LCD keypad. The LCD keypad supports multi-language display and 10-line high-definition display. Its overall size is the same as the LED keypad. Both the external LED keypad and LCD keypad support the parameter copy function.



Note:

- For mounting the keypad externally (including LED and LCD keypads), use a standard RJ45 network cable as the extension cable. Mount the keypad on the front panel of the cabinet using M3 screws or an optional keypad bracket.
- When the external keypad is active, the built-in LED keypad remains unaffected, and both can be used simultaneously.

5.2 Local LED keypad display and operation

The local LED keypad consists mainly of status indicators, LED digital tube display, and keys.

5.2.1 Keypad panel

5.2.1.1 Status indicator

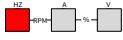
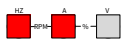
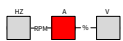
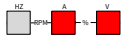
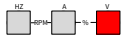
| Indicator | Status | Description | |
|----------------|---|--|---------------------|
| RUN/TUNE | <input checked="" type="checkbox"/> ON | The VFD is running. | |
| | <input checked="" type="checkbox"/> Blink | The VFD is in parameter autotuning. | |
| | <input type="checkbox"/> Off | The VFD is stopped. | |
| FWD/REV | <input checked="" type="checkbox"/> ON | The VFD runs reversely. | |
| | <input type="checkbox"/> Off | The VFD runs forward. | |
| LOCAL/REMOT | <input checked="" type="checkbox"/> ON | The VFD uses communication as the command running channel. | |
| | <input checked="" type="checkbox"/> Blink | The VFD uses terminal as the command running channel. | |
| | <input type="checkbox"/> Off | The VFD uses keypad as the command running channel. | |
| RUN/TUNE | <input checked="" type="checkbox"/> On, displaying the fault code | The VFD is in fault state. | |
| FWD/REV | <input checked="" type="checkbox"/> Blinking at the same time | The VFD is in alarm state. | |
| LOCAL/REMOT | | | |
| Unit indicator | A unit indicator that is on indicates the unit currently displayed on the keypad. | | |
| |  | Hz | Frequency unit |
| |  | RPM | Rotation speed unit |
| |  | A | Current unit |
| |  | % | Percentage |
| |  | V | Voltage unit |







Note: The unit indicator blinking and turning-on are generally used to distinguish different stop and running parameter display.

5.2.1.2 Display area

The display area displays a 5-digit value, including fault alarm code, set frequency, output frequency, and functional status data.

| Display | Means | Display | Means | Display | Means | Display | Means |
|---------|-------|---------|-------|---------|-------|---------|-------|
| 0 | 0 | 1 | 1 | 2 | 2 | 3 | 3 |
| 4 | 4 | 5 | 5 | 6 | 6 | 7 | 7 |
| 8 | 8 | 9 | 9 | A | A | b | b |
| C | C | d | d | E | E | F | F |
| H | H | l | l | L | L | N | N |
| n | n | O | O | P | P | r | r |
| S | S | t | t | U | U | v | v |
| . | . | - | - | | | | |

5.2.1.3 Key

| Key | | Function |
|---|---|--|
|  | Programming/ Multifunction shortcut key | Press it to enter or exit level-1 menus or delete a parameter. Press and hold it (at least 1s) to implement the function defined by the ones place of P07.02, which is jogging by default. |
|  | Confirmation/ Shifting key | Press it to enter menus in cascading mode or confirm the setting of a parameter. Press it to select display parameters in the interface for the VFD in stopped or running state. Press and hold it (at least 1s) or to select digits to change during parameter setting. |
|  | Up key | Press it to increase data or move upward. |
|  | Down key | Press it to decrease data or move downward. |
|  | Run key | Press it to run or perform autotuning under keypad operation mode. |
|  | Stop/ Reset key | P07.04 specifies the validity of the key function. Press it to stop running or autotuning in running state. Press it to reset in fault alarm state. |
|  | Potentiometer (A13) | Local LED keypad potentiometer, that is, A13. |

5.2.2 Keypad display

The keypad display content varies under different states. The following describes the keypad display content under different states.

Figure 5- 4 Status homepage display

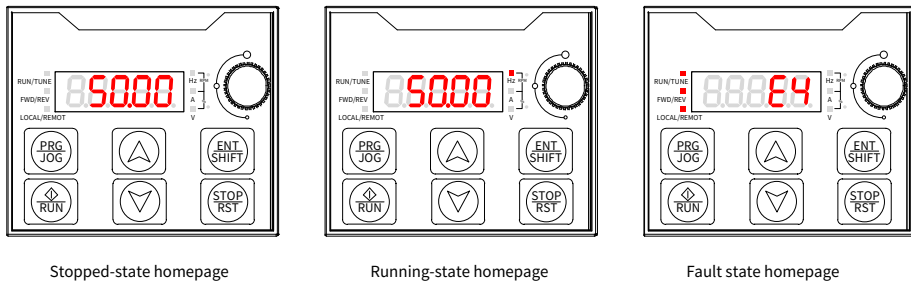

5.2.2.1 Displaying stopped-state parameters

When the VFD is in stopped state, and the keypad is not in the function code viewing or editing state, the keypad displays stopped-state parameters. By setting P07.08, you can select different stopped-state parameters. Press **ENT/SHIFT** to switch the parameters.

5.2.2.2 Displaying running-state parameters

When the VFD is in running state, and the keypad is not in the function code viewing or editing state, the keypad displays running-state parameters. By setting P07.05 and P07.06, you can select different running-state parameters. Press **ENT/SHIFT** to switch the parameters.

5.2.2.3 Fault display

When the VFD is in fault state, and the keypad is not in the function code viewing or editing state, the keypad displays the fault code in blinking way. You can perform fault reset by using the **STOP/RST** key, control terminals, or communication commands. If the fault persists, the fault state and fault code display are kept.

When the VFD is in fault display state, and the keypad is in the function code viewing or editing state, the keypad automatically returns to the fault state display if there is no operation within 20s. When there is no fault with the VFD, after entering the third-level menu of changing a function code with the attribute "●", the value of the function code will be displayed continuously. In other cases, if there is no operation on the keypad within 1 minute, the keypad will automatically return to the stopped-state or running-state parameter display from the function code viewing or editing state.

5.2.3 Operation procedure

5.2.3.1 Modifying function parameters

The keypad contains three levels of menus according to operation editing settings.

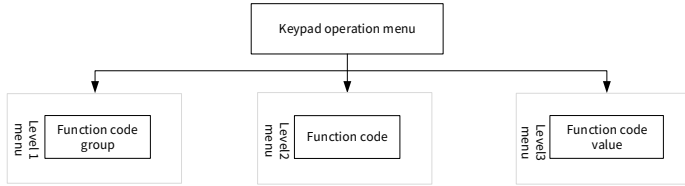

When the VFD is in stopped, running, or fault display state:

Press **PRG/JOG** to enter the level-one menu (if a user password has been set, see the description of P07.00).

Under the level-two menu, press **ENT/SHIFT** to enter the next-level menu.

Under the level-three menu, press **ENT/SHIFT** to save the current function code value and enter the level-two menu of the next function code.

Note: Under various levels of menus, press **PRG/JOG** to return to the previous level of menu, press **▲** or **▼** to increase or decrease the value of the current blinking bit, and press and hold **ENT/SHIFT** to switch the blinking bit rightward in circular mode.

If you enter the level-3 menu but the parameter does not have a digit blinking, the parameter cannot be modified due to either of the following reasons:

It is read only. Read-only parameters include actual detection parameters and running record parameters.

It cannot be modified in running state and can be modified only in stopped state.

The following takes P03.20 as an example to describe how to modify a function parameter in the stopped-state parameter display interface:

Figure 5-4 Modifying a parameter

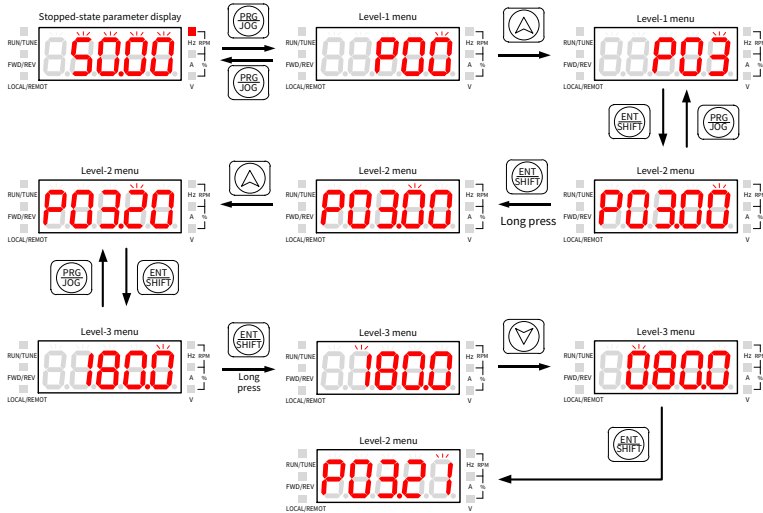

Note: When P00.18 is set to 3, any function code value does not blink, and any function code value cannot be modified.

5.2.3.2 Setting a password for the VFD

The VFD provides the user password protection function. When P07.00 is set to a non-zero value, the function code editing state is exited, and password protection will take effect within one minute. After the password takes effect, when the VFD is in the stopped, running, or fault display state, you need to type the user password after pressing the **PRG/JOG** key so as to enter the function code viewing and editing state.

The following takes setting the user password 10001 as an example to describe how to set a password for the VFD in the stopped-state parameter display interface:

Figure 5-5 Setting a password

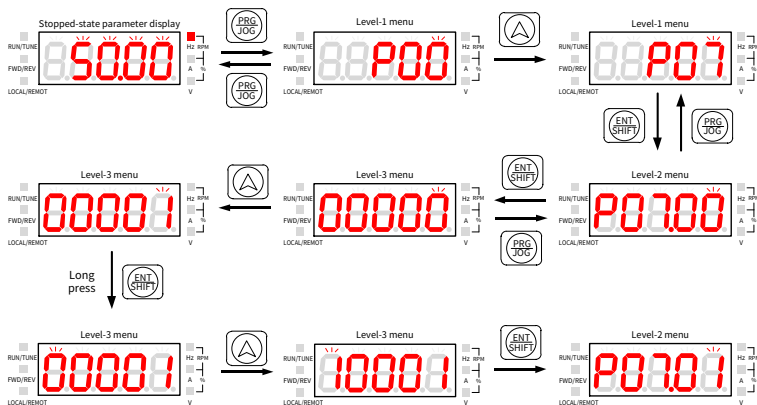

5.2.3.3 Viewing function parameters

The VFD provides the status viewing function. The following describes how to view function parameters in the stopped-state parameter display interface when the password is 10001:

Figure 5-6 Viewing a function code

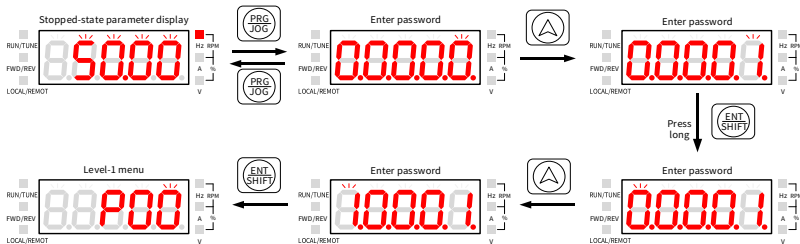













5.3 External LED keypad display and operation

The external LED keypad consists of three main parts: status indicators, digital display area, and keys. A standard RJ45 network cable is required as an extension cable for the keypad. The external LED keypad is the same as the built-in LED keypad in terms of main display and operation, but it has slight differences in the status indicators and keys.

5.3.1 Keypad panel

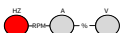
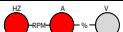

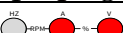
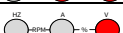
5.3.1.1 Status indicator







| Indicator | Status | Description | |
|----------------|---|--|---------------------|
| RUN/TUNE |  ON | The VFD is running. | |
| |  Blink | The VFD is in parameter autotuning. | |
| |  Off | The VFD is stopped. | |
| FWD/REV |  ON | The VFD runs reversely. | |
| |  Off | The VFD runs forward. | |
| LOCAL/REMOT |  ON | The VFD uses communication as the command running channel. | |
| |  Blink | The VFD uses terminal as the command running channel. | |
| |  Off | The VFD uses keypad as the command running channel. | |
| TRIP |  ON | The VFD is in fault state. | |
| |  Blink | The VFD is in alarm state. | |
| |  Off | The VFD is in normal state. | |
| Unit indicator | A unit indicator that is on indicates the unit currently displayed on the keypad. | | |
| |  | Hz | Frequency unit |
| |  | RPM | Rotation speed unit |
| |  | A | Current unit |
| |  | % | Percentage |
| |  | V | Voltage unit |

5.3.1.2 Display area

The LED keypad and local LED keypad are the same in the digital display. For details, see section 5.2.1.2 Display area.

5.3.1.3 Key

| Key | Function |
|---|--|
|  PRG ESC | Programming key Press it to enter or exit level-1 menus or delete a parameter. |
|  DATA ENT | Confirmation key Press it to enter menus in cascading mode or confirm the setting of a parameter. |

| Key | Function |
|---|--|
|  | Up key Press it to increase data or move upward. |
|  | Down key Press it to decrease data or move downward. |
|  | Shifting key Press it to select display parameters rightward in the interface for the product in stopped or running state or to select digits to change during parameter setting. |
|  | Run key Press it to run or perform autotuning under keypad operation mode. |
|  | Stop/Reset key P07.04 specifies the validity of the key function. Press it to stop running or autotuning in running state. Press it to reset in fault alarm state. |
|  | Digital potentiometer See P08.44 for the digital potentiometer function. |

5.3.2 Keypad display

There are three display states: stopped-state parameter display, running-state parameter display, and faulty display.

Figure 5- 6 Status homepage display

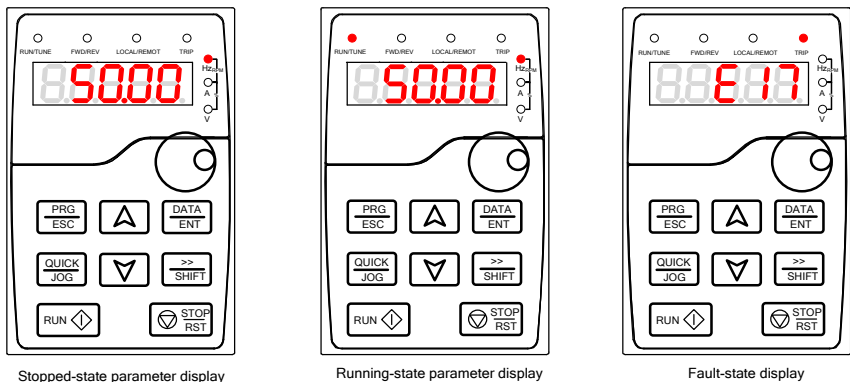

5.3.2.1 Displaying stopped-state parameters

When the VFD is in stopped state, and the keypad is not in the function code viewing or

editing state, the keypad displays stopped-state parameters. By setting P07.08, you can select different stopped-state parameters, and press **SHIFT** to switch the parameters.

5.3.2.2 Displaying running-state parameters

When the VFD is in running state, and the keypad is not in the function code viewing or editing state, the keypad displays running-state parameters. By setting P07.05 and P07.06, you can select different running-state parameters, and press **SHIFT** to switch the parameters.

5.3.2.3 Fault display

When the VFD is in fault state, and the keypad is not in the function code viewing or editing state, the keypad displays the fault code in blinking way. You can perform fault reset by using the **STOP/RST** key, control terminals, or communication commands. If the fault persists, the fault state and fault code display are kept.

When the VFD is in fault display state, and the keypad is in the function code viewing or editing state, the keypad automatically returns to the fault state display if there is no operation within 20s. When there is no fault with the VFD, after entering the third-level menu of changing a function code with the attribute "●", the value of the function code will be displayed continuously. In other cases, if there is no operation on the keypad within 1 minute, the keypad will automatically return to the stopped-state or running-state parameter display from the function code viewing or editing state.

5.3.3 Operation procedure

5.3.3.1 Modifying function parameters

The VFD provides three levels of menus, including:

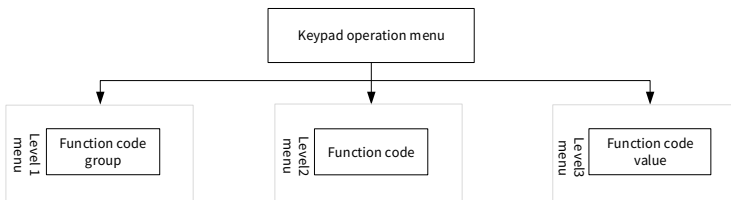

When the VFD is in stopped, running, or fault display state:

Press **PRG/ESC** to enter the level-one menu (if a user password has been set, see the description of P07.00).

Under the level-two menu, press **DATA/ENT** to enter the next-level menu.

Under the level-three menu, press **DATA/ENT** to save the current function code value and enter the level-two menu of the next function code.

Note: Under various levels of menus, press **PRG/ESC** to return to the previous level of menu, press **▲** or **▼** to increase or decrease the value of the blinking bit, and press **SHIFT** to switch the blinking bit rightward in circular mode.

If you enter the level-3 menu but the parameter does not have a digit blinking, the parameter cannot be modified due to either of the following reasons:

It is read only. Read-only parameters include actual detection parameters and running record parameters.

It cannot be modified in running state and can be modified only in stopped state.

Example: Change the value of P00.01 from 0 to 1.

Figure 5-7 Modifying a parameter

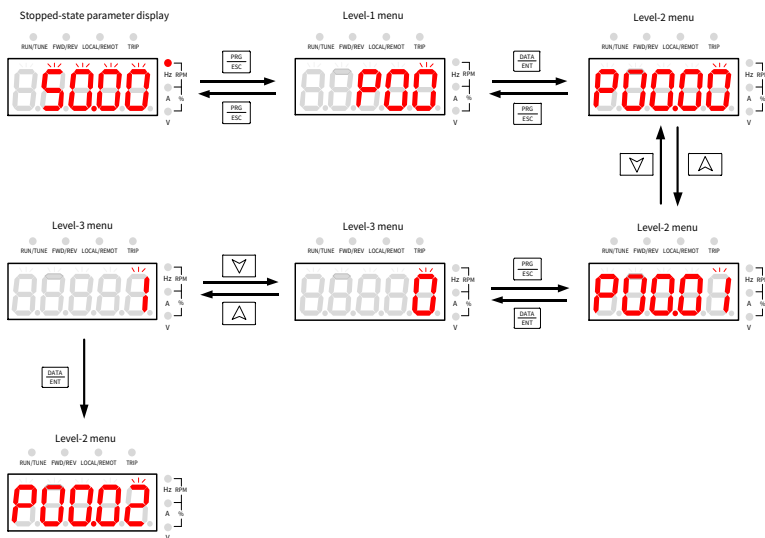

5.3.3.2 Setting a password for the VFD

The VFD provides the user password protection function. When P07.00 is set to a non-zero value, the function code editing state is exited, and password protection will take effect within one minute. After the password takes effect, when the VFD is in the stopped, running, or fault display state, you need to type the user password after pressing the **PRG/ESC** key so as to enter the function code viewing and editing state.

The following takes setting the user password 10001 as an example to describe how to set a password for the VFD in the stopped-state parameter display interface:

Figure 5- 8 Setting a password

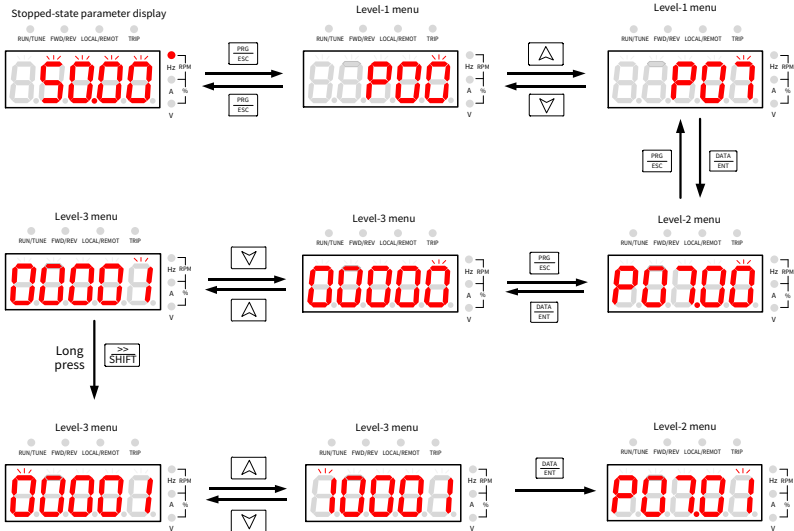

5.3.3.3 Viewing function parameters

The VFD provides the status viewing function. The following describes how to view function parameters in the stopped-state parameter display interface when the password is 10001:

Figure 5-9 Viewing a parameter

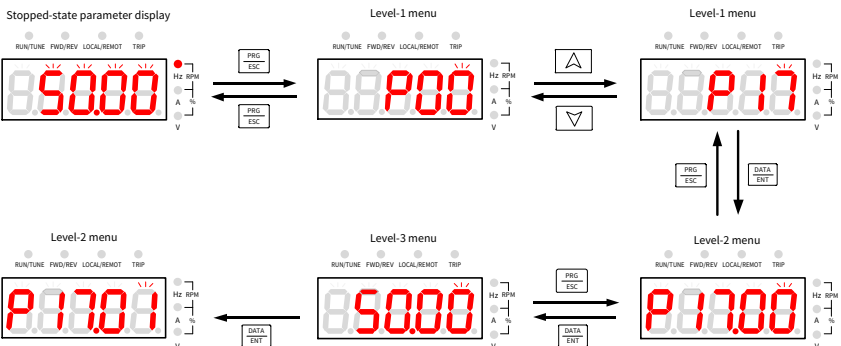

5.4 External LCD keypad display and operation

The VFD supports an optional external LCD keypad, through which various functions can be realized, such as: controlling the start and stop, reading status data, setting parameters, and copying parameters of the VFD.

5.4.1 Keypad panel

5.4.1.1 Status indicator

| Indicator | Status | Description |
|-----------|----------|--|
| RUN | ◆ ON | The VFD is running. |
| | ◀◆ Blink | The VFD is in parameter autotuning. |
| | ◇ Off | The VFD is stopped. |
| TRIP | ◆ ON | The VFD is in fault state. |
| | ◀◆ Blink | The VFD is in alarm state. |
| | ◇ Off | The VFD is in normal state. |
| QUICK/JOG | ● ON | The displayed state varies depending on the short-cut key function. For details, see the definition of |
| | ◐ Blink | |
| | ○ Off | QUICK/JOG. |





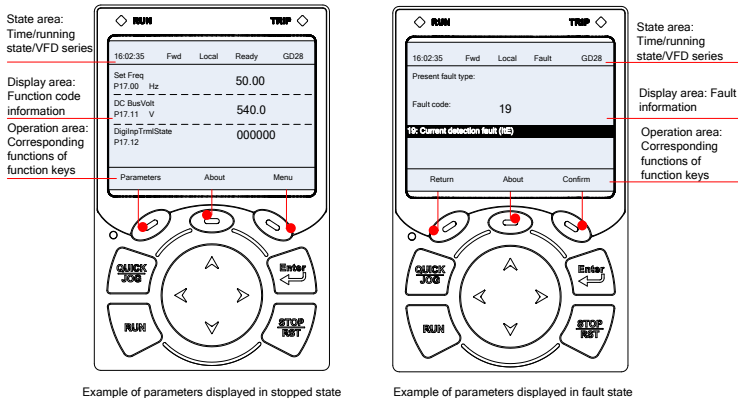





5.4.1.2 Display screen









The display shows different content depending on the operating scenario.



5.4.1.3 Key

| Key | Function |
|-----|---|
| | Function key Press it to display the function on the corresponding page |

| Key | | Function |
|---|------------------|--|
|  | | position. |
|  | | |
|  | Short-cut key | The ones place of P07.02 defines the key function, which is jogging by default and can be redefined. For details, see the description of P07.02. |
|  | Confirmation key | The function of this key varies depending on the menu, such as confirming parameter settings, selecting parameters, or entering a sub-menu. |
|  | Run key | Press it to run or perform autotuning under keypad operation mode. |
|  | Stop/Reset key | The function code P07.04 specifies the validity of the key function. Press it to stop running or autotuning in running state. Press it to reset in fault alarm state. |
|  | Direction key | <p>The function of the direction key varies with interfaces.</p> <p>Up key : Press it to move the item up or increase the value.</p> <p>Down key : Press it to move the item down or decrease the value.</p> <p>Left key : Press it to switch the page, move the cursor to the left, or return to the previous menu.</p> <p>Right key : Press it to switch the page, move the cursor to the right, or enter the next menu.</p> |

 **Note:** In general, you can press  or  or  to enter the current cursor-lighted menu; you can press  or to  return to the previous menu. In the following, take  or  as an example to enter the present menu or return to the previous menu.

5.4.2 Keypad functions

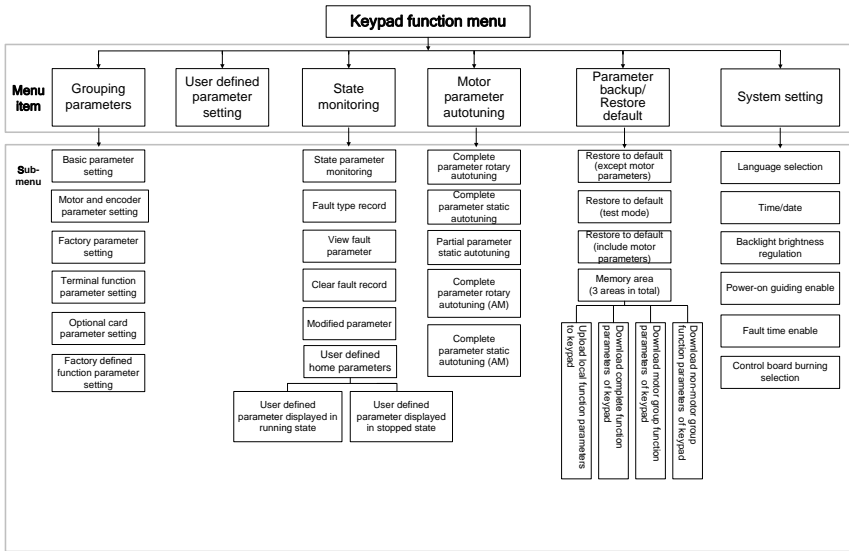

5.4.3 Operation procedure

You can operate the VFD through the keypad homepage **Menu** regardless of whether the VFD is stopped or running.

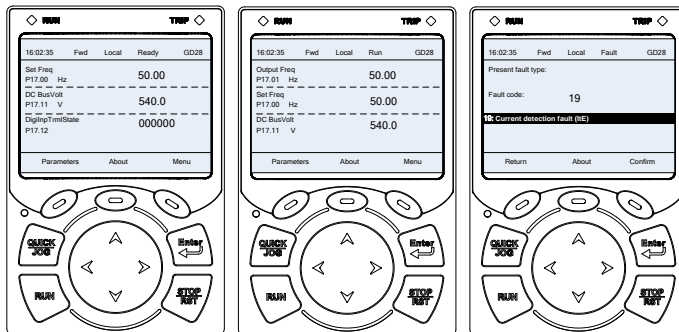

Stopped state homepage

Running state homepage

Fault state homepage











Once a fault is detected, the keypad displays the fault code and fault information with the indicator on the keypad turning on. You can perform fault reset by using the **STOP/RST** key, control terminals, or communication commands.

5.4.3.1 Entering/Exiting menus

The following figures show how to enter/exit menu in the stopped state.

 **Note:** Limited by the keypad display area, items can be displayed by multiple pages.









You can press the down key  to display full items.

| | | | | | | | | | | | | | | | | | | | | | | | | | | | | | | | | | | | | | | | | | | | | | | | | | | | | | | | | | | | | | | | | | | | | | | | | | | | | |
|---|----------|-------|--------|-------|------|----------------------------|----|--|-------|--|------------------------------|---|--|-------|--|--------------------------|--|--|--------|--|-------------------------|--|--|--|--|--|----------|-----|-------|-------|---------------------------|---------------------|--|--|--|--------------------|----------------------------------|--|--|--|---|------------------|-----|-------|-------|------|----------------------------|----|--|-------|--|----------------------------------|---|--|-------|--|------------------------|--|--|--------|--|------------------------|--|--|--|--|-------------------------------|--|--|--|--|------------------------|--|--|--|--|
| <p>Step 1 In the stopped state homepage, press the key  corresponding to Menu to select the menu item.</p> <table border="1"> <tr> <td>16:02:35</td> <td>Fwd</td> <td>Local</td> <td>Ready</td> <td>GD28</td> </tr> <tr> <td>Set Freq P17.00</td> <td>Hz</td> <td></td> <td>50.00</td> <td></td> </tr> <tr> <td>DC BusVolt P17.11</td> <td>V</td> <td></td> <td>540.0</td> <td></td> </tr> <tr> <td>DigInpTrmlState P17.12</td> <td></td> <td></td> <td>000000</td> <td></td> </tr> <tr> <td colspan="5">Parameters About Menu</td> </tr> </table> | 16:02:35 | Fwd | Local | Ready | GD28 | Set Freq P17.00 | Hz | | 50.00 | | DC BusVolt P17.11 | V | | 540.0 | | DigInpTrmlState P17.12 | | | 000000 | | Parameters About Menu | | | | | <p>Step 2 Press the down key  to select User defined parameter setting and press the key  to confirm.</p> <table border="1"> <tr> <td>16:02:35</td> <td>Fwd</td> <td>Local</td> <td>Ready</td> <td>GD28</td> </tr> <tr> <td colspan="5">Grouping parameters</td> </tr> <tr> <td colspan="5">User defined parameter setting ▶</td> </tr> <tr> <td colspan="5">State monitoring</td> </tr> <tr> <td colspan="5">Motor parameter autotuning</td> </tr> <tr> <td colspan="5">Parameter backup/Restore default</td> </tr> <tr> <td colspan="5">System setting</td> </tr> <tr> <td colspan="5">Return Homepage Select</td> </tr> </table> | 16:02:35 | Fwd | Local | Ready | GD28 | Grouping parameters | | | | | User defined parameter setting ▶ | | | | | State monitoring | | | | | Motor parameter autotuning | | | | | Parameter backup/Restore default | | | | | System setting | | | | | Return Homepage Select | | | | | | | | | | | | | | |
| 16:02:35 | Fwd | Local | Ready | GD28 | | | | | | | | | | | | | | | | | | | | | | | | | | | | | | | | | | | | | | | | | | | | | | | | | | | | | | | | | | | | | | | | | | | | | | | | |
| Set Freq P17.00 | Hz | | 50.00 | | | | | | | | | | | | | | | | | | | | | | | | | | | | | | | | | | | | | | | | | | | | | | | | | | | | | | | | | | | | | | | | | | | | | | | | | |
| DC BusVolt P17.11 | V | | 540.0 | | | | | | | | | | | | | | | | | | | | | | | | | | | | | | | | | | | | | | | | | | | | | | | | | | | | | | | | | | | | | | | | | | | | | | | | | |
| DigInpTrmlState P17.12 | | | 000000 | | | | | | | | | | | | | | | | | | | | | | | | | | | | | | | | | | | | | | | | | | | | | | | | | | | | | | | | | | | | | | | | | | | | | | | | | |
| Parameters About Menu | | | | | | | | | | | | | | | | | | | | | | | | | | | | | | | | | | | | | | | | | | | | | | | | | | | | | | | | | | | | | | | | | | | | | | | | | | | | |
| 16:02:35 | Fwd | Local | Ready | GD28 | | | | | | | | | | | | | | | | | | | | | | | | | | | | | | | | | | | | | | | | | | | | | | | | | | | | | | | | | | | | | | | | | | | | | | | | |
| Grouping parameters | | | | | | | | | | | | | | | | | | | | | | | | | | | | | | | | | | | | | | | | | | | | | | | | | | | | | | | | | | | | | | | | | | | | | | | | | | | | |
| User defined parameter setting ▶ | | | | | | | | | | | | | | | | | | | | | | | | | | | | | | | | | | | | | | | | | | | | | | | | | | | | | | | | | | | | | | | | | | | | | | | | | | | | |
| State monitoring | | | | | | | | | | | | | | | | | | | | | | | | | | | | | | | | | | | | | | | | | | | | | | | | | | | | | | | | | | | | | | | | | | | | | | | | | | | | |
| Motor parameter autotuning | | | | | | | | | | | | | | | | | | | | | | | | | | | | | | | | | | | | | | | | | | | | | | | | | | | | | | | | | | | | | | | | | | | | | | | | | | | | |
| Parameter backup/Restore default | | | | | | | | | | | | | | | | | | | | | | | | | | | | | | | | | | | | | | | | | | | | | | | | | | | | | | | | | | | | | | | | | | | | | | | | | | | | |
| System setting | | | | | | | | | | | | | | | | | | | | | | | | | | | | | | | | | | | | | | | | | | | | | | | | | | | | | | | | | | | | | | | | | | | | | | | | | | | | |
| Return Homepage Select | | | | | | | | | | | | | | | | | | | | | | | | | | | | | | | | | | | | | | | | | | | | | | | | | | | | | | | | | | | | | | | | | | | | | | | | | | | | |
| <p>Step 3 Press  or  key to select the function code.</p> <table border="1"> <tr> <td>16:02:35</td> <td>Fwd</td> <td>Local</td> <td>Ready</td> <td>GD28</td> </tr> <tr> <td colspan="5">P00.00: Speed Control Mode</td> </tr> <tr> <td colspan="5">P00.01: Run Cmd Channel ▶</td> </tr> <tr> <td colspan="5">P00.02: Comm Cmd Channel</td> </tr> <tr> <td colspan="5">P00.03: Max Output Freq</td> </tr> <tr> <td colspan="5">P00.04: RunFreq Up Limit</td> </tr> <tr> <td colspan="5">P00.05: RunFreq Low Limit</td> </tr> <tr> <td colspan="5">Return Edit Select</td> </tr> </table> | 16:02:35 | Fwd | Local | Ready | GD28 | P00.00: Speed Control Mode | | | | | P00.01: Run Cmd Channel ▶ | | | | | P00.02: Comm Cmd Channel | | | | | P00.03: Max Output Freq | | | | | P00.04: RunFreq Up Limit | | | | | P00.05: RunFreq Low Limit | | | | | Return Edit Select | | | | | <p>Step 4 After pressing the key  corresponding to Edit, press the key  corresponding to Place top to confirm.</p> <table border="1"> <tr> <td>16:02:35</td> <td>Fwd</td> <td>Local</td> <td>Ready</td> <td>GD28</td> </tr> <tr> <td colspan="5">Place top ▶</td> </tr> <tr> <td colspan="5">Move up</td> </tr> <tr> <td colspan="5">Move down</td> </tr> <tr> <td colspan="5">Delete from the list</td> </tr> <tr> <td colspan="5">Restore to default parameters</td> </tr> <tr> <td colspan="5">Return Homepage Select</td> </tr> </table> | 16:02:35 | Fwd | Local | Ready | GD28 | Place top ▶ | | | | | Move up | | | | | Move down | | | | | Delete from the list | | | | | Restore to default parameters | | | | | Return Homepage Select | | | | |
| 16:02:35 | Fwd | Local | Ready | GD28 | | | | | | | | | | | | | | | | | | | | | | | | | | | | | | | | | | | | | | | | | | | | | | | | | | | | | | | | | | | | | | | | | | | | | | | | |
| P00.00: Speed Control Mode | | | | | | | | | | | | | | | | | | | | | | | | | | | | | | | | | | | | | | | | | | | | | | | | | | | | | | | | | | | | | | | | | | | | | | | | | | | | |
| P00.01: Run Cmd Channel ▶ | | | | | | | | | | | | | | | | | | | | | | | | | | | | | | | | | | | | | | | | | | | | | | | | | | | | | | | | | | | | | | | | | | | | | | | | | | | | |
| P00.02: Comm Cmd Channel | | | | | | | | | | | | | | | | | | | | | | | | | | | | | | | | | | | | | | | | | | | | | | | | | | | | | | | | | | | | | | | | | | | | | | | | | | | | |
| P00.03: Max Output Freq | | | | | | | | | | | | | | | | | | | | | | | | | | | | | | | | | | | | | | | | | | | | | | | | | | | | | | | | | | | | | | | | | | | | | | | | | | | | |
| P00.04: RunFreq Up Limit | | | | | | | | | | | | | | | | | | | | | | | | | | | | | | | | | | | | | | | | | | | | | | | | | | | | | | | | | | | | | | | | | | | | | | | | | | | | |
| P00.05: RunFreq Low Limit | | | | | | | | | | | | | | | | | | | | | | | | | | | | | | | | | | | | | | | | | | | | | | | | | | | | | | | | | | | | | | | | | | | | | | | | | | | | |
| Return Edit Select | | | | | | | | | | | | | | | | | | | | | | | | | | | | | | | | | | | | | | | | | | | | | | | | | | | | | | | | | | | | | | | | | | | | | | | | | | | | |
| 16:02:35 | Fwd | Local | Ready | GD28 | | | | | | | | | | | | | | | | | | | | | | | | | | | | | | | | | | | | | | | | | | | | | | | | | | | | | | | | | | | | | | | | | | | | | | | | |
| Place top ▶ | | | | | | | | | | | | | | | | | | | | | | | | | | | | | | | | | | | | | | | | | | | | | | | | | | | | | | | | | | | | | | | | | | | | | | | | | | | | |
| Move up | | | | | | | | | | | | | | | | | | | | | | | | | | | | | | | | | | | | | | | | | | | | | | | | | | | | | | | | | | | | | | | | | | | | | | | | | | | | |
| Move down | | | | | | | | | | | | | | | | | | | | | | | | | | | | | | | | | | | | | | | | | | | | | | | | | | | | | | | | | | | | | | | | | | | | | | | | | | | | |
| Delete from the list | | | | | | | | | | | | | | | | | | | | | | | | | | | | | | | | | | | | | | | | | | | | | | | | | | | | | | | | | | | | | | | | | | | | | | | | | | | | |
| Restore to default parameters | | | | | | | | | | | | | | | | | | | | | | | | | | | | | | | | | | | | | | | | | | | | | | | | | | | | | | | | | | | | | | | | | | | | | | | | | | | | |
| Return Homepage Select | | | | | | | | | | | | | | | | | | | | | | | | | | | | | | | | | | | | | | | | | | | | | | | | | | | | | | | | | | | | | | | | | | | | | | | | | | | | |
| <p>Step 5 Press the key  corresponding to Return to return to the previous menu.</p> <table border="1"> <tr> <td>16:02:35</td> <td>Fwd</td> <td>Local</td> <td>Ready</td> <td>GD28</td> </tr> <tr> <td colspan="5">P00.01: Run Cmd Channel</td> </tr> <tr> <td colspan="5">P00.00: Speed Control Mode ▶</td> </tr> <tr> <td colspan="5">P00.02: Comm Cmd Channel</td> </tr> <tr> <td colspan="5">P00.03: Max Output Freq</td> </tr> <tr> <td colspan="5">P00.04: RunFreq Up Limit</td> </tr> <tr> <td colspan="5">P00.05: RunFreq Low Limit</td> </tr> <tr> <td colspan="5">Return Edit Select</td> </tr> </table> | 16:02:35 | Fwd | Local | Ready | GD28 | P00.01: Run Cmd Channel | | | | | P00.00: Speed Control Mode ▶ | | | | | P00.02: Comm Cmd Channel | | | | | P00.03: Max Output Freq | | | | | P00.04: RunFreq Up Limit | | | | | P00.05: RunFreq Low Limit | | | | | Return Edit Select | | | | | <p>Step 6 Press the key  corresponding to Return or press the key  corresponding to Homepage to return to the homepage.</p> <table border="1"> <tr> <td>16:02:35</td> <td>Fwd</td> <td>Local</td> <td>Ready</td> <td>GD28</td> </tr> <tr> <td>Set Freq P17.00</td> <td>Hz</td> <td></td> <td>50.00</td> <td></td> </tr> <tr> <td>DC BusVolt P17.11</td> <td>V</td> <td></td> <td>540.0</td> <td></td> </tr> <tr> <td>DigInpTrmlState P17.12</td> <td></td> <td></td> <td>000000</td> <td></td> </tr> <tr> <td colspan="5">Parameters About Menu</td> </tr> </table> | 16:02:35 | Fwd | Local | Ready | GD28 | Set Freq P17.00 | Hz | | 50.00 | | DC BusVolt P17.11 | V | | 540.0 | | DigInpTrmlState P17.12 | | | 000000 | | Parameters About Menu | | | | | | | | | | | | | | |
| 16:02:35 | Fwd | Local | Ready | GD28 | | | | | | | | | | | | | | | | | | | | | | | | | | | | | | | | | | | | | | | | | | | | | | | | | | | | | | | | | | | | | | | | | | | | | | | | |
| P00.01: Run Cmd Channel | | | | | | | | | | | | | | | | | | | | | | | | | | | | | | | | | | | | | | | | | | | | | | | | | | | | | | | | | | | | | | | | | | | | | | | | | | | | |
| P00.00: Speed Control Mode ▶ | | | | | | | | | | | | | | | | | | | | | | | | | | | | | | | | | | | | | | | | | | | | | | | | | | | | | | | | | | | | | | | | | | | | | | | | | | | | |
| P00.02: Comm Cmd Channel | | | | | | | | | | | | | | | | | | | | | | | | | | | | | | | | | | | | | | | | | | | | | | | | | | | | | | | | | | | | | | | | | | | | | | | | | | | | |
| P00.03: Max Output Freq | | | | | | | | | | | | | | | | | | | | | | | | | | | | | | | | | | | | | | | | | | | | | | | | | | | | | | | | | | | | | | | | | | | | | | | | | | | | |
| P00.04: RunFreq Up Limit | | | | | | | | | | | | | | | | | | | | | | | | | | | | | | | | | | | | | | | | | | | | | | | | | | | | | | | | | | | | | | | | | | | | | | | | | | | | |
| P00.05: RunFreq Low Limit | | | | | | | | | | | | | | | | | | | | | | | | | | | | | | | | | | | | | | | | | | | | | | | | | | | | | | | | | | | | | | | | | | | | | | | | | | | | |
| Return Edit Select | | | | | | | | | | | | | | | | | | | | | | | | | | | | | | | | | | | | | | | | | | | | | | | | | | | | | | | | | | | | | | | | | | | | | | | | | | | | |
| 16:02:35 | Fwd | Local | Ready | GD28 | | | | | | | | | | | | | | | | | | | | | | | | | | | | | | | | | | | | | | | | | | | | | | | | | | | | | | | | | | | | | | | | | | | | | | | | |
| Set Freq P17.00 | Hz | | 50.00 | | | | | | | | | | | | | | | | | | | | | | | | | | | | | | | | | | | | | | | | | | | | | | | | | | | | | | | | | | | | | | | | | | | | | | | | | |
| DC BusVolt P17.11 | V | | 540.0 | | | | | | | | | | | | | | | | | | | | | | | | | | | | | | | | | | | | | | | | | | | | | | | | | | | | | | | | | | | | | | | | | | | | | | | | | |
| DigInpTrmlState P17.12 | | | 000000 | | | | | | | | | | | | | | | | | | | | | | | | | | | | | | | | | | | | | | | | | | | | | | | | | | | | | | | | | | | | | | | | | | | | | | | | | |
| Parameters About Menu | | | | | | | | | | | | | | | | | | | | | | | | | | | | | | | | | | | | | | | | | | | | | | | | | | | | | | | | | | | | | | | | | | | | | | | | | | | | |

5.4.3.2 Editing the parameter list

You can edit the user-defined parameter list (in the stopped state or running state), and the editing operations include **Place top**, **Move up**, **Move down**, **Delete from the list**, and **Restore to default parameters**.

























The operation example is as follows:

| | | | | | | | | | | | | | | | | | | | | | | | | | | | | | | | | | | | | | | | | | | | | | | | | | | | | | | | | | | | | | | | | | | | | | | | | | | | | |
|--|----------|--------|-------|-------|------|----------------------------|----|-------|--|--|----------------------|---|-------|--|--|---------------------------|--|--------|--|--|-----------------------------|--|--|--|--|---|----------|-----|-------|-------|-------------------------------------|---------------------|--|--|--|------------------------------|--------------------------------|--|--|--|---|-------------------------|-----|-------|-------|------|---|--|--|--|--|---|--|--|--|--|------------------------------|--|--|--|--|------------------------------|--|--|--|--|-------------------------------|--|--|--|--|------------------------------|--|--|--|--|
| <p>Step 1 In the stopped state homepage, press the key  corresponding to Menu to select the menu item.</p> <table border="1" data-bbox="135 464 423 667"> <tr> <td>16:02:35</td> <td>Fwd</td> <td>Local</td> <td>Ready</td> <td>GD28</td> </tr> <tr> <td>Set Freq P17.00</td> <td>Hz</td> <td colspan="3">50.00</td> </tr> <tr> <td>DC BusVolt P17.11</td> <td>V</td> <td colspan="3">540.0</td> </tr> <tr> <td>DigInpTrmlState P17.12</td> <td></td> <td colspan="3">000000</td> </tr> <tr> <td colspan="5">Parameters About Menu</td> </tr> </table> | 16:02:35 | Fwd | Local | Ready | GD28 | Set Freq P17.00 | Hz | 50.00 | | | DC BusVolt P17.11 | V | 540.0 | | | DigInpTrmlState P17.12 | | 000000 | | | Parameters About Menu | | | | | <p>Step 2 Press  to select State monitoring and press  to confirm.</p> <table border="1" data-bbox="568 464 856 667"> <tr> <td>16:02:35</td> <td>Fwd</td> <td>Local</td> <td>Ready</td> <td>GD28</td> </tr> <tr> <td colspan="5">Grouping parameters</td> </tr> <tr> <td colspan="5">User defined parameter setting</td> </tr> <tr> <td colspan="5">State monitoring</td> </tr> <tr> <td colspan="5">Motor parameter autotuning</td> </tr> <tr> <td colspan="5">Parameter backup/Restore default</td> </tr> <tr> <td colspan="5">System setting</td> </tr> <tr> <td colspan="5">Return Homepage Select</td> </tr> </table> | 16:02:35 | Fwd | Local | Ready | GD28 | Grouping parameters | | | | | User defined parameter setting | | | | | State monitoring | | | | | Motor parameter autotuning | | | | | Parameter backup/Restore default | | | | | System setting | | | | | Return Homepage Select | | | | | | | | | | | | | | |
| 16:02:35 | Fwd | Local | Ready | GD28 | | | | | | | | | | | | | | | | | | | | | | | | | | | | | | | | | | | | | | | | | | | | | | | | | | | | | | | | | | | | | | | | | | | | | | | | |
| Set Freq P17.00 | Hz | 50.00 | | | | | | | | | | | | | | | | | | | | | | | | | | | | | | | | | | | | | | | | | | | | | | | | | | | | | | | | | | | | | | | | | | | | | | | | | | |
| DC BusVolt P17.11 | V | 540.0 | | | | | | | | | | | | | | | | | | | | | | | | | | | | | | | | | | | | | | | | | | | | | | | | | | | | | | | | | | | | | | | | | | | | | | | | | | |
| DigInpTrmlState P17.12 | | 000000 | | | | | | | | | | | | | | | | | | | | | | | | | | | | | | | | | | | | | | | | | | | | | | | | | | | | | | | | | | | | | | | | | | | | | | | | | | |
| Parameters About Menu | | | | | | | | | | | | | | | | | | | | | | | | | | | | | | | | | | | | | | | | | | | | | | | | | | | | | | | | | | | | | | | | | | | | | | | | | | | | |
| 16:02:35 | Fwd | Local | Ready | GD28 | | | | | | | | | | | | | | | | | | | | | | | | | | | | | | | | | | | | | | | | | | | | | | | | | | | | | | | | | | | | | | | | | | | | | | | | |
| Grouping parameters | | | | | | | | | | | | | | | | | | | | | | | | | | | | | | | | | | | | | | | | | | | | | | | | | | | | | | | | | | | | | | | | | | | | | | | | | | | | |
| User defined parameter setting | | | | | | | | | | | | | | | | | | | | | | | | | | | | | | | | | | | | | | | | | | | | | | | | | | | | | | | | | | | | | | | | | | | | | | | | | | | | |
| State monitoring | | | | | | | | | | | | | | | | | | | | | | | | | | | | | | | | | | | | | | | | | | | | | | | | | | | | | | | | | | | | | | | | | | | | | | | | | | | | |
| Motor parameter autotuning | | | | | | | | | | | | | | | | | | | | | | | | | | | | | | | | | | | | | | | | | | | | | | | | | | | | | | | | | | | | | | | | | | | | | | | | | | | | |
| Parameter backup/Restore default | | | | | | | | | | | | | | | | | | | | | | | | | | | | | | | | | | | | | | | | | | | | | | | | | | | | | | | | | | | | | | | | | | | | | | | | | | | | |
| System setting | | | | | | | | | | | | | | | | | | | | | | | | | | | | | | | | | | | | | | | | | | | | | | | | | | | | | | | | | | | | | | | | | | | | | | | | | | | | |
| Return Homepage Select | | | | | | | | | | | | | | | | | | | | | | | | | | | | | | | | | | | | | | | | | | | | | | | | | | | | | | | | | | | | | | | | | | | | | | | | | | | | |
| <p>Step 3 Press  to select User defined home parameters and press  to confirm.</p> <table border="1" data-bbox="135 799 423 1002"> <tr> <td>16:02:35</td> <td>Fwd</td> <td>Local</td> <td>Ready</td> <td>GD28</td> </tr> <tr> <td colspan="5">State parameter monitoring</td> </tr> <tr> <td colspan="5">Fault type record</td> </tr> <tr> <td colspan="5">View fault parameter</td> </tr> <tr> <td colspan="5">Clear fault record</td> </tr> <tr> <td colspan="5">Modified parameter</td> </tr> <tr> <td colspan="5">User defined home parameters</td> </tr> <tr> <td colspan="5">Return Homepage Select</td> </tr> </table> | 16:02:35 | Fwd | Local | Ready | GD28 | State parameter monitoring | | | | | Fault type record | | | | | View fault parameter | | | | | Clear fault record | | | | | Modified parameter | | | | | User defined home parameters | | | | | Return Homepage Select | | | | | <p>Step 4 Press  to select User defined prm displayed in stop state.</p> <table border="1" data-bbox="568 799 856 1002"> <tr> <td>16:02:35</td> <td>Fwd</td> <td>Local</td> <td>Ready</td> <td>GD28</td> </tr> <tr> <td colspan="5">User defined prm displayed in stop state</td> </tr> <tr> <td colspan="5">User defined prm displayed in run state</td> </tr> <tr> <td colspan="5">Return Homepage Select</td> </tr> </table> | 16:02:35 | Fwd | Local | Ready | GD28 | User defined prm displayed in stop state | | | | | User defined prm displayed in run state | | | | | Return Homepage Select | | | | | | | | | | | | | | | | | | | |
| 16:02:35 | Fwd | Local | Ready | GD28 | | | | | | | | | | | | | | | | | | | | | | | | | | | | | | | | | | | | | | | | | | | | | | | | | | | | | | | | | | | | | | | | | | | | | | | | |
| State parameter monitoring | | | | | | | | | | | | | | | | | | | | | | | | | | | | | | | | | | | | | | | | | | | | | | | | | | | | | | | | | | | | | | | | | | | | | | | | | | | | |
| Fault type record | | | | | | | | | | | | | | | | | | | | | | | | | | | | | | | | | | | | | | | | | | | | | | | | | | | | | | | | | | | | | | | | | | | | | | | | | | | | |
| View fault parameter | | | | | | | | | | | | | | | | | | | | | | | | | | | | | | | | | | | | | | | | | | | | | | | | | | | | | | | | | | | | | | | | | | | | | | | | | | | | |
| Clear fault record | | | | | | | | | | | | | | | | | | | | | | | | | | | | | | | | | | | | | | | | | | | | | | | | | | | | | | | | | | | | | | | | | | | | | | | | | | | | |
| Modified parameter | | | | | | | | | | | | | | | | | | | | | | | | | | | | | | | | | | | | | | | | | | | | | | | | | | | | | | | | | | | | | | | | | | | | | | | | | | | | |
| User defined home parameters | | | | | | | | | | | | | | | | | | | | | | | | | | | | | | | | | | | | | | | | | | | | | | | | | | | | | | | | | | | | | | | | | | | | | | | | | | | | |
| Return Homepage Select | | | | | | | | | | | | | | | | | | | | | | | | | | | | | | | | | | | | | | | | | | | | | | | | | | | | | | | | | | | | | | | | | | | | | | | | | | | | |
| 16:02:35 | Fwd | Local | Ready | GD28 | | | | | | | | | | | | | | | | | | | | | | | | | | | | | | | | | | | | | | | | | | | | | | | | | | | | | | | | | | | | | | | | | | | | | | | | |
| User defined prm displayed in stop state | | | | | | | | | | | | | | | | | | | | | | | | | | | | | | | | | | | | | | | | | | | | | | | | | | | | | | | | | | | | | | | | | | | | | | | | | | | | |
| User defined prm displayed in run state | | | | | | | | | | | | | | | | | | | | | | | | | | | | | | | | | | | | | | | | | | | | | | | | | | | | | | | | | | | | | | | | | | | | | | | | | | | | |
| Return Homepage Select | | | | | | | | | | | | | | | | | | | | | | | | | | | | | | | | | | | | | | | | | | | | | | | | | | | | | | | | | | | | | | | | | | | | | | | | | | | | |
| <p>Step 5 Press  to select the function code P17.00.</p> <table border="1" data-bbox="135 1094 423 1297"> <tr> <td>16:02:35</td> <td>Fwd</td> <td>Local</td> <td>Ready</td> <td>GD28</td> </tr> <tr> <td colspan="5">P17.00: Set Freq</td> </tr> <tr> <td colspan="5">P17.11: DC BusVolt</td> </tr> <tr> <td colspan="5">P17.12: DigInpTrmlState</td> </tr> <tr> <td colspan="5">P17.13: RO2/RO1/HDO/Y1</td> </tr> <tr> <td colspan="5">P17.26: Present OperTime</td> </tr> <tr> <td colspan="5">P17.15: Motor Trq Ref</td> </tr> <tr> <td colspan="5">Return Edit Select</td> </tr> </table> | 16:02:35 | Fwd | Local | Ready | GD28 | P17.00: Set Freq | | | | | P17.11: DC BusVolt | | | | | P17.12: DigInpTrmlState | | | | | P17.13: RO2/RO1/HDO/Y1 | | | | | P17.26: Present OperTime | | | | | P17.15: Motor Trq Ref | | | | | Return Edit Select | | | | | <p>Step 6 Press  to select Place top.</p> <table border="1" data-bbox="568 1094 856 1297"> <tr> <td>16:02:35</td> <td>Fwd</td> <td>Local</td> <td>Ready</td> <td>GD28</td> </tr> <tr> <td colspan="5">Place top</td> </tr> <tr> <td colspan="5">Move up</td> </tr> <tr> <td colspan="5">Move down</td> </tr> <tr> <td colspan="5">Delete from the list</td> </tr> <tr> <td colspan="5">Restore to default parameters</td> </tr> <tr> <td colspan="5">Return Homepage Select</td> </tr> </table> | 16:02:35 | Fwd | Local | Ready | GD28 | Place top | | | | | Move up | | | | | Move down | | | | | Delete from the list | | | | | Restore to default parameters | | | | | Return Homepage Select | | | | |
| 16:02:35 | Fwd | Local | Ready | GD28 | | | | | | | | | | | | | | | | | | | | | | | | | | | | | | | | | | | | | | | | | | | | | | | | | | | | | | | | | | | | | | | | | | | | | | | | |
| P17.00: Set Freq | | | | | | | | | | | | | | | | | | | | | | | | | | | | | | | | | | | | | | | | | | | | | | | | | | | | | | | | | | | | | | | | | | | | | | | | | | | | |
| P17.11: DC BusVolt | | | | | | | | | | | | | | | | | | | | | | | | | | | | | | | | | | | | | | | | | | | | | | | | | | | | | | | | | | | | | | | | | | | | | | | | | | | | |
| P17.12: DigInpTrmlState | | | | | | | | | | | | | | | | | | | | | | | | | | | | | | | | | | | | | | | | | | | | | | | | | | | | | | | | | | | | | | | | | | | | | | | | | | | | |
| P17.13: RO2/RO1/HDO/Y1 | | | | | | | | | | | | | | | | | | | | | | | | | | | | | | | | | | | | | | | | | | | | | | | | | | | | | | | | | | | | | | | | | | | | | | | | | | | | |
| P17.26: Present OperTime | | | | | | | | | | | | | | | | | | | | | | | | | | | | | | | | | | | | | | | | | | | | | | | | | | | | | | | | | | | | | | | | | | | | | | | | | | | | |
| P17.15: Motor Trq Ref | | | | | | | | | | | | | | | | | | | | | | | | | | | | | | | | | | | | | | | | | | | | | | | | | | | | | | | | | | | | | | | | | | | | | | | | | | | | |
| Return Edit Select | | | | | | | | | | | | | | | | | | | | | | | | | | | | | | | | | | | | | | | | | | | | | | | | | | | | | | | | | | | | | | | | | | | | | | | | | | | | |
| 16:02:35 | Fwd | Local | Ready | GD28 | | | | | | | | | | | | | | | | | | | | | | | | | | | | | | | | | | | | | | | | | | | | | | | | | | | | | | | | | | | | | | | | | | | | | | | | |
| Place top | | | | | | | | | | | | | | | | | | | | | | | | | | | | | | | | | | | | | | | | | | | | | | | | | | | | | | | | | | | | | | | | | | | | | | | | | | | | |
| Move up | | | | | | | | | | | | | | | | | | | | | | | | | | | | | | | | | | | | | | | | | | | | | | | | | | | | | | | | | | | | | | | | | | | | | | | | | | | | |
| Move down | | | | | | | | | | | | | | | | | | | | | | | | | | | | | | | | | | | | | | | | | | | | | | | | | | | | | | | | | | | | | | | | | | | | | | | | | | | | |
| Delete from the list | | | | | | | | | | | | | | | | | | | | | | | | | | | | | | | | | | | | | | | | | | | | | | | | | | | | | | | | | | | | | | | | | | | | | | | | | | | | |
| Restore to default parameters | | | | | | | | | | | | | | | | | | | | | | | | | | | | | | | | | | | | | | | | | | | | | | | | | | | | | | | | | | | | | | | | | | | | | | | | | | | | |
| Return Homepage Select | | | | | | | | | | | | | | | | | | | | | | | | | | | | | | | | | | | | | | | | | | | | | | | | | | | | | | | | | | | | | | | | | | | | | | | | | | | | |

5.4.3.3 Adding parameters

Parameter list displayed in the stopped/running state

The operation example is as follows:

| | | | | | | | | | | | | | | | | | | | | | | | | | | | | | | | | | | | | | | | | | | | | | | | | | | | | | | | | | | | | | | | | | | | | | | | | | | | | |
|--|--|----------|--------|--------|------|---|----|--|-------|--|----------------------|---|--|-------|--|--------------------------|--|--|--------|--|--------------------|--|-------|--|------|---|----------|-----|-------|-------|------------------------------|---------------------|--|--|--|--------|--------------------------------|----------|--|--------|--|---|-----|-------|-------|------|--|--|--|--|--|--|--|--|--|--|-------------------------|--|----------|--|--------|------------------------|--|----------|--|--------|-------------------------------|--|--|--|--|--------|--|----------|--|--------|
| <p>Step 1 In the stopped state homepage, press the key  corresponding to Menu to select the menu item.</p> <table border="1" style="width: 100%; border-collapse: collapse; margin-top: 10px;"> <tr> <td style="font-size: small;">16:02:35</td> <td style="font-size: small;">Fwd</td> <td style="font-size: small;">Local</td> <td style="font-size: small;">Ready</td> <td style="font-size: small;">GD28</td> </tr> <tr> <td>Set Freq P17.00</td> <td colspan="2">Hz</td> <td colspan="2">50.00</td> </tr> <tr> <td>DC BusVolt P17.11</td> <td colspan="2">V</td> <td colspan="2">540.0</td> </tr> <tr> <td>DigInPrmiState P17.12</td> <td colspan="2"></td> <td colspan="2">000000</td> </tr> <tr> <td colspan="2" style="text-align: center;">Parameters</td> <td colspan="2" style="text-align: center;">About</td> <td style="text-align: center;">Menu</td> </tr> </table> | 16:02:35 | Fwd | Local | Ready | GD28 | Set Freq P17.00 | Hz | | 50.00 | | DC BusVolt P17.11 | V | | 540.0 | | DigInPrmiState P17.12 | | | 000000 | | Parameters | | About | | Menu | <p>Step 2 Press  to select State monitoring and press  to confirm.</p> <table border="1" style="width: 100%; border-collapse: collapse; margin-top: 10px;"> <tr> <td style="font-size: small;">16:02:35</td> <td style="font-size: small;">Fwd</td> <td style="font-size: small;">Local</td> <td style="font-size: small;">Ready</td> <td style="font-size: small;">GD28</td> </tr> <tr> <td colspan="5">Grouping parameters</td> </tr> <tr> <td colspan="5">User defined parameter setting</td> </tr> <tr> <td colspan="5">State monitoring </td> </tr> <tr> <td colspan="5">Motor parameter autotuning</td> </tr> <tr> <td colspan="5">Parameter backup/Restore default</td> </tr> <tr> <td colspan="5">System setting</td> </tr> <tr> <td colspan="2" style="text-align: center;">Return</td> <td colspan="2" style="text-align: center;">Homepage</td> <td style="text-align: center;">Select</td> </tr> </table> | 16:02:35 | Fwd | Local | Ready | GD28 | Grouping parameters | | | | | User defined parameter setting | | | | | State monitoring  | | | | | Motor parameter autotuning | | | | | Parameter backup/Restore default | | | | | System setting | | | | | Return | | Homepage | | Select | | | | | | | | | | |
| 16:02:35 | Fwd | Local | Ready | GD28 | | | | | | | | | | | | | | | | | | | | | | | | | | | | | | | | | | | | | | | | | | | | | | | | | | | | | | | | | | | | | | | | | | | | | | | | |
| Set Freq P17.00 | Hz | | 50.00 | | | | | | | | | | | | | | | | | | | | | | | | | | | | | | | | | | | | | | | | | | | | | | | | | | | | | | | | | | | | | | | | | | | | | | | | | |
| DC BusVolt P17.11 | V | | 540.0 | | | | | | | | | | | | | | | | | | | | | | | | | | | | | | | | | | | | | | | | | | | | | | | | | | | | | | | | | | | | | | | | | | | | | | | | | |
| DigInPrmiState P17.12 | | | 000000 | | | | | | | | | | | | | | | | | | | | | | | | | | | | | | | | | | | | | | | | | | | | | | | | | | | | | | | | | | | | | | | | | | | | | | | | | |
| Parameters | | About | | Menu | | | | | | | | | | | | | | | | | | | | | | | | | | | | | | | | | | | | | | | | | | | | | | | | | | | | | | | | | | | | | | | | | | | | | | | | |
| 16:02:35 | Fwd | Local | Ready | GD28 | | | | | | | | | | | | | | | | | | | | | | | | | | | | | | | | | | | | | | | | | | | | | | | | | | | | | | | | | | | | | | | | | | | | | | | | |
| Grouping parameters | | | | | | | | | | | | | | | | | | | | | | | | | | | | | | | | | | | | | | | | | | | | | | | | | | | | | | | | | | | | | | | | | | | | | | | | | | | | |
| User defined parameter setting | | | | | | | | | | | | | | | | | | | | | | | | | | | | | | | | | | | | | | | | | | | | | | | | | | | | | | | | | | | | | | | | | | | | | | | | | | | | |
| State monitoring  | | | | | | | | | | | | | | | | | | | | | | | | | | | | | | | | | | | | | | | | | | | | | | | | | | | | | | | | | | | | | | | | | | | | | | | | | | | | |
| Motor parameter autotuning | | | | | | | | | | | | | | | | | | | | | | | | | | | | | | | | | | | | | | | | | | | | | | | | | | | | | | | | | | | | | | | | | | | | | | | | | | | | |
| Parameter backup/Restore default | | | | | | | | | | | | | | | | | | | | | | | | | | | | | | | | | | | | | | | | | | | | | | | | | | | | | | | | | | | | | | | | | | | | | | | | | | | | |
| System setting | | | | | | | | | | | | | | | | | | | | | | | | | | | | | | | | | | | | | | | | | | | | | | | | | | | | | | | | | | | | | | | | | | | | | | | | | | | | |
| Return | | Homepage | | Select | | | | | | | | | | | | | | | | | | | | | | | | | | | | | | | | | | | | | | | | | | | | | | | | | | | | | | | | | | | | | | | | | | | | | | | | |
| <p>Step 3 Select State parameter monitoring and press  to confirm.</p> <table border="1" style="width: 100%; border-collapse: collapse; margin-top: 10px;"> <tr> <td style="font-size: small;">16:02:35</td> <td style="font-size: small;">Fwd</td> <td style="font-size: small;">Local</td> <td style="font-size: small;">Ready</td> <td style="font-size: small;">GD28</td> </tr> <tr> <td colspan="5">State parameter monitoring </td> </tr> <tr> <td colspan="5">Fault type record</td> </tr> <tr> <td colspan="5">View fault parameter</td> </tr> <tr> <td colspan="5">Clear fault record</td> </tr> <tr> <td colspan="5">Modified parameter</td> </tr> <tr> <td colspan="5">User defined home parameters</td> </tr> <tr> <td colspan="2" style="text-align: center;">Return</td> <td colspan="2" style="text-align: center;">Homepage</td> <td style="text-align: center;">Select</td> </tr> </table> | 16:02:35 | Fwd | Local | Ready | GD28 | State parameter monitoring  | | | | | Fault type record | | | | | View fault parameter | | | | | Clear fault record | | | | | Modified parameter | | | | | User defined home parameters | | | | | Return | | Homepage | | Select | <p>Step 4 Press  to select function code group P17 and press  to confirm.</p> <table border="1" style="width: 100%; border-collapse: collapse; margin-top: 10px;"> <tr> <td style="font-size: small;">16:02:35</td> <td style="font-size: small;">Fwd</td> <td style="font-size: small;">Local</td> <td style="font-size: small;">Ready</td> <td style="font-size: small;">GD28</td> </tr> <tr> <td colspan="5">P07: HMI</td> </tr> <tr> <td colspan="5">P17: State Viewing Func </td> </tr> <tr> <td colspan="5">P18: Cl-IpCtrlStateView</td> </tr> <tr> <td colspan="5">P19: Ex-card StateView</td> </tr> <tr> <td colspan="5">P93: TensionCtrl StateViewing</td> </tr> <tr> <td colspan="2" style="text-align: center;">Return</td> <td colspan="2" style="text-align: center;">Homepage</td> <td style="text-align: center;">Select</td> </tr> </table> | 16:02:35 | Fwd | Local | Ready | GD28 | P07: HMI | | | | | P17: State Viewing Func  | | | | | P18: Cl-IpCtrlStateView | | | | | P19: Ex-card StateView | | | | | P93: TensionCtrl StateViewing | | | | | Return | | Homepage | | Select |
| 16:02:35 | Fwd | Local | Ready | GD28 | | | | | | | | | | | | | | | | | | | | | | | | | | | | | | | | | | | | | | | | | | | | | | | | | | | | | | | | | | | | | | | | | | | | | | | | |
| State parameter monitoring  | | | | | | | | | | | | | | | | | | | | | | | | | | | | | | | | | | | | | | | | | | | | | | | | | | | | | | | | | | | | | | | | | | | | | | | | | | | | |
| Fault type record | | | | | | | | | | | | | | | | | | | | | | | | | | | | | | | | | | | | | | | | | | | | | | | | | | | | | | | | | | | | | | | | | | | | | | | | | | | | |
| View fault parameter | | | | | | | | | | | | | | | | | | | | | | | | | | | | | | | | | | | | | | | | | | | | | | | | | | | | | | | | | | | | | | | | | | | | | | | | | | | | |
| Clear fault record | | | | | | | | | | | | | | | | | | | | | | | | | | | | | | | | | | | | | | | | | | | | | | | | | | | | | | | | | | | | | | | | | | | | | | | | | | | | |
| Modified parameter | | | | | | | | | | | | | | | | | | | | | | | | | | | | | | | | | | | | | | | | | | | | | | | | | | | | | | | | | | | | | | | | | | | | | | | | | | | | |
| User defined home parameters | | | | | | | | | | | | | | | | | | | | | | | | | | | | | | | | | | | | | | | | | | | | | | | | | | | | | | | | | | | | | | | | | | | | | | | | | | | | |
| Return | | Homepage | | Select | | | | | | | | | | | | | | | | | | | | | | | | | | | | | | | | | | | | | | | | | | | | | | | | | | | | | | | | | | | | | | | | | | | | | | | | |
| 16:02:35 | Fwd | Local | Ready | GD28 | | | | | | | | | | | | | | | | | | | | | | | | | | | | | | | | | | | | | | | | | | | | | | | | | | | | | | | | | | | | | | | | | | | | | | | | |
| P07: HMI | | | | | | | | | | | | | | | | | | | | | | | | | | | | | | | | | | | | | | | | | | | | | | | | | | | | | | | | | | | | | | | | | | | | | | | | | | | | |
| P17: State Viewing Func  | | | | | | | | | | | | | | | | | | | | | | | | | | | | | | | | | | | | | | | | | | | | | | | | | | | | | | | | | | | | | | | | | | | | | | | | | | | | |
| P18: Cl-IpCtrlStateView | | | | | | | | | | | | | | | | | | | | | | | | | | | | | | | | | | | | | | | | | | | | | | | | | | | | | | | | | | | | | | | | | | | | | | | | | | | | |
| P19: Ex-card StateView | | | | | | | | | | | | | | | | | | | | | | | | | | | | | | | | | | | | | | | | | | | | | | | | | | | | | | | | | | | | | | | | | | | | | | | | | | | | |
| P93: TensionCtrl StateViewing | | | | | | | | | | | | | | | | | | | | | | | | | | | | | | | | | | | | | | | | | | | | | | | | | | | | | | | | | | | | | | | | | | | | | | | | | | | | |
| Return | | Homepage | | Select | | | | | | | | | | | | | | | | | | | | | | | | | | | | | | | | | | | | | | | | | | | | | | | | | | | | | | | | | | | | | | | | | | | | | | | | |
| <p>Step 5 Press the key  corresponding to Add.</p> <table border="1" style="width: 100%; border-collapse: collapse; margin-top: 10px;"> <tr> <td style="font-size: small;">16:02:35</td> <td style="font-size: small;">Fwd</td> <td style="font-size: small;">Local</td> <td style="font-size: small;">Ready</td> <td style="font-size: small;">GD28</td> </tr> <tr> <td colspan="5">P17.00: Set Freq </td> </tr> <tr> <td colspan="5">P17.01: Output Freq</td> </tr> <tr> <td colspan="5">P17.02: Ramp RefFreq</td> </tr> <tr> <td colspan="5">P17.03: OutpVolt</td> </tr> <tr> <td colspan="5">P17.04: OutpCur</td> </tr> <tr> <td colspan="5">P17.05: Motor Speed</td> </tr> <tr> <td colspan="2" style="text-align: center;">Return</td> <td colspan="2" style="text-align: center;">Add</td> <td style="text-align: center;">Select</td> </tr> </table> | 16:02:35 | Fwd | Local | Ready | GD28 | P17.00: Set Freq  | | | | | P17.01: Output Freq | | | | | P17.02: Ramp RefFreq | | | | | P17.03: OutpVolt | | | | | P17.04: OutpCur | | | | | P17.05: Motor Speed | | | | | Return | | Add | | Select | <p>Step 6 Press  to select User defined prm displayed in stop state.</p> <table border="1" style="width: 100%; border-collapse: collapse; margin-top: 10px;"> <tr> <td style="font-size: small;">16:02:35</td> <td style="font-size: small;">Fwd</td> <td style="font-size: small;">Local</td> <td style="font-size: small;">Ready</td> <td style="font-size: small;">GD28</td> </tr> <tr> <td colspan="5">User defined prm displayed in stop state </td> </tr> <tr> <td colspan="5">User defined prm displayed in run state</td> </tr> <tr> <td colspan="2" style="text-align: center;">Return</td> <td colspan="2" style="text-align: center;">Homepage</td> <td style="text-align: center;">Select</td> </tr> </table> | 16:02:35 | Fwd | Local | Ready | GD28 | User defined prm displayed in stop state  | | | | | User defined prm displayed in run state | | | | | Return | | Homepage | | Select | | | | | | | | | | | | | | | |
| 16:02:35 | Fwd | Local | Ready | GD28 | | | | | | | | | | | | | | | | | | | | | | | | | | | | | | | | | | | | | | | | | | | | | | | | | | | | | | | | | | | | | | | | | | | | | | | | |
| P17.00: Set Freq  | | | | | | | | | | | | | | | | | | | | | | | | | | | | | | | | | | | | | | | | | | | | | | | | | | | | | | | | | | | | | | | | | | | | | | | | | | | | |
| P17.01: Output Freq | | | | | | | | | | | | | | | | | | | | | | | | | | | | | | | | | | | | | | | | | | | | | | | | | | | | | | | | | | | | | | | | | | | | | | | | | | | | |
| P17.02: Ramp RefFreq | | | | | | | | | | | | | | | | | | | | | | | | | | | | | | | | | | | | | | | | | | | | | | | | | | | | | | | | | | | | | | | | | | | | | | | | | | | | |
| P17.03: OutpVolt | | | | | | | | | | | | | | | | | | | | | | | | | | | | | | | | | | | | | | | | | | | | | | | | | | | | | | | | | | | | | | | | | | | | | | | | | | | | |
| P17.04: OutpCur | | | | | | | | | | | | | | | | | | | | | | | | | | | | | | | | | | | | | | | | | | | | | | | | | | | | | | | | | | | | | | | | | | | | | | | | | | | | |
| P17.05: Motor Speed | | | | | | | | | | | | | | | | | | | | | | | | | | | | | | | | | | | | | | | | | | | | | | | | | | | | | | | | | | | | | | | | | | | | | | | | | | | | |
| Return | | Add | | Select | | | | | | | | | | | | | | | | | | | | | | | | | | | | | | | | | | | | | | | | | | | | | | | | | | | | | | | | | | | | | | | | | | | | | | | | |
| 16:02:35 | Fwd | Local | Ready | GD28 | | | | | | | | | | | | | | | | | | | | | | | | | | | | | | | | | | | | | | | | | | | | | | | | | | | | | | | | | | | | | | | | | | | | | | | | |
| User defined prm displayed in stop state  | | | | | | | | | | | | | | | | | | | | | | | | | | | | | | | | | | | | | | | | | | | | | | | | | | | | | | | | | | | | | | | | | | | | | | | | | | | | |
| User defined prm displayed in run state | | | | | | | | | | | | | | | | | | | | | | | | | | | | | | | | | | | | | | | | | | | | | | | | | | | | | | | | | | | | | | | | | | | | | | | | | | | | |
| Return | | Homepage | | Select | | | | | | | | | | | | | | | | | | | | | | | | | | | | | | | | | | | | | | | | | | | | | | | | | | | | | | | | | | | | | | | | | | | | | | | | |
| <p>Step 7 Press the key  corresponding to confirm.</p> | <p>Step 8 After the page returns to the current function code group, continue adding function codes or return to the previous menu.</p> | | | | | | | | | | | | | | | | | | | | | | | | | | | | | | | | | | | | | | | | | | | | | | | | | | | | | | | | | | | | | | | | | | | | | | | | | | | |

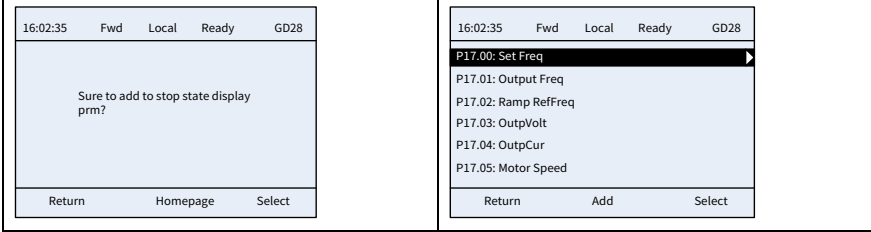

User defined parameter list

The operation example is as follows:

| | | | | | | | | | | | | | | | | | | | | | | | | | | | | | | | | | | | | | | | | | | | | | | |
|--|--|----------|-------|--------|------|------------------------|----|--|--|-------|--------------------------------|---|--|--|-------|--|--|--|--|--------|------------|--|----------|--|--------|--|----------|-----|-------|-------|------|----------------------------|--|--|--|--|---|--|--|--|--|--------|--|----------|--|--------|
| <p>Step 1 In the stopped state homepage, press the key corresponding to Menu to select the menu item.</p> <table border="1" style="width: 100%; border-collapse: collapse; margin-top: 10px;"> <tr> <td style="font-size: small;">16:02:35</td> <td style="font-size: small;">Fwd</td> <td style="font-size: small;">Local</td> <td style="font-size: small;">Ready</td> <td style="font-size: small;">GD28</td> </tr> <tr> <td style="font-size: small;">Set Freq P17.00</td> <td style="font-size: small;">Hz</td> <td colspan="2"></td> <td style="font-size: small;">50.00</td> </tr> <tr> <td style="font-size: small;">DC BusVolt P17.11</td> <td style="font-size: small;">V</td> <td colspan="2"></td> <td style="font-size: small;">540.0</td> </tr> <tr> <td style="font-size: small;">DigInpTrmiState P17.12</td> <td></td> <td colspan="2"></td> <td style="font-size: small;">000000</td> </tr> <tr> <td colspan="2" style="font-size: small;">Parameters</td> <td colspan="2" style="font-size: small;">About</td> <td style="font-size: small;">Menu</td> </tr> </table> | 16:02:35 | Fwd | Local | Ready | GD28 | Set Freq P17.00 | Hz | | | 50.00 | DC BusVolt P17.11 | V | | | 540.0 | DigInpTrmiState P17.12 | | | | 000000 | Parameters | | About | | Menu | <p>Step 2 Select Grouping parameters and press to confirm.</p> <table border="1" style="width: 100%; border-collapse: collapse; margin-top: 10px;"> <tr> <td style="font-size: small;">16:02:35</td> <td style="font-size: small;">Fwd</td> <td style="font-size: small;">Local</td> <td style="font-size: small;">Ready</td> <td style="font-size: small;">GD28</td> </tr> <tr> <td colspan="5" style="padding: 5px;"> Grouping parameters </td> </tr> <tr> <td colspan="5" style="padding: 5px;"> User defined parameter setting State monitoring Motor parameter autotuning Parameter backup/Restore default System setting </td> </tr> <tr> <td colspan="2" style="font-size: small;">Return</td> <td colspan="2" style="font-size: small;">Homepage</td> <td style="font-size: small;">Select</td> </tr> </table> | 16:02:35 | Fwd | Local | Ready | GD28 | Grouping parameters | | | | | User defined parameter setting State monitoring Motor parameter autotuning Parameter backup/Restore default System setting | | | | | Return | | Homepage | | Select |
| 16:02:35 | Fwd | Local | Ready | GD28 | | | | | | | | | | | | | | | | | | | | | | | | | | | | | | | | | | | | | | | | | | |
| Set Freq P17.00 | Hz | | | 50.00 | | | | | | | | | | | | | | | | | | | | | | | | | | | | | | | | | | | | | | | | | | |
| DC BusVolt P17.11 | V | | | 540.0 | | | | | | | | | | | | | | | | | | | | | | | | | | | | | | | | | | | | | | | | | | |
| DigInpTrmiState P17.12 | | | | 000000 | | | | | | | | | | | | | | | | | | | | | | | | | | | | | | | | | | | | | | | | | | |
| Parameters | | About | | Menu | | | | | | | | | | | | | | | | | | | | | | | | | | | | | | | | | | | | | | | | | | |
| 16:02:35 | Fwd | Local | Ready | GD28 | | | | | | | | | | | | | | | | | | | | | | | | | | | | | | | | | | | | | | | | | | |
| Grouping parameters | | | | | | | | | | | | | | | | | | | | | | | | | | | | | | | | | | | | | | | | | | | | | | |
| User defined parameter setting State monitoring Motor parameter autotuning Parameter backup/Restore default System setting | | | | | | | | | | | | | | | | | | | | | | | | | | | | | | | | | | | | | | | | | | | | | | |
| Return | | Homepage | | Select | | | | | | | | | | | | | | | | | | | | | | | | | | | | | | | | | | | | | | | | | | |
| <p>Step 3 Press to select P01, and press to confirm.</p> <table border="1" style="width: 100%; border-collapse: collapse; margin-top: 10px;"> <tr> <td style="font-size: small;">16:02:35</td> <td style="font-size: small;">Fwd</td> <td style="font-size: small;">Local</td> <td style="font-size: small;">Ready</td> <td style="font-size: small;">GD28</td> </tr> <tr> <td colspan="5" style="padding: 5px;"> P00: Basic Func </td> </tr> <tr> <td colspan="5" style="padding: 5px;"> P01: Start/stop Control </td> </tr> <tr> <td colspan="5" style="padding: 5px;"> P03: Motor 1 Vector Ctrl P04: V/F control P07: HMI P08: Enhanced Function </td> </tr> <tr> <td colspan="2" style="font-size: small;">Return</td> <td colspan="2" style="font-size: small;">Homepage</td> <td style="font-size: small;">Select</td> </tr> </table> | 16:02:35 | Fwd | Local | Ready | GD28 | P00: Basic Func | | | | | P01: Start/stop Control | | | | | P03: Motor 1 Vector Ctrl P04: V/F control P07: HMI P08: Enhanced Function | | | | | Return | | Homepage | | Select | <p>Step 4 Press the key corresponding to Add.</p> <table border="1" style="width: 100%; border-collapse: collapse; margin-top: 10px;"> <tr> <td style="font-size: small;">16:02:35</td> <td style="font-size: small;">Fwd</td> <td style="font-size: small;">Local</td> <td style="font-size: small;">Ready</td> <td style="font-size: small;">GD28</td> </tr> <tr> <td colspan="5" style="padding: 5px;"> P01.00: Start mode </td> </tr> <tr> <td colspan="5" style="padding: 5px;"> P01.01: DirectStart Freq P01.02: StartFreq HoldTime P01.03: Prestart BrakeCur P01.04: Prestart BrakeTime P01.05: ACC/DEC Mode </td> </tr> <tr> <td colspan="2" style="font-size: small;">Return</td> <td colspan="2" style="font-size: small;">Add</td> <td style="font-size: small;">Select</td> </tr> </table> | 16:02:35 | Fwd | Local | Ready | GD28 | P01.00: Start mode | | | | | P01.01: DirectStart Freq P01.02: StartFreq HoldTime P01.03: Prestart BrakeCur P01.04: Prestart BrakeTime P01.05: ACC/DEC Mode | | | | | Return | | Add | | Select |
| 16:02:35 | Fwd | Local | Ready | GD28 | | | | | | | | | | | | | | | | | | | | | | | | | | | | | | | | | | | | | | | | | | |
| P00: Basic Func | | | | | | | | | | | | | | | | | | | | | | | | | | | | | | | | | | | | | | | | | | | | | | |
| P01: Start/stop Control | | | | | | | | | | | | | | | | | | | | | | | | | | | | | | | | | | | | | | | | | | | | | | |
| P03: Motor 1 Vector Ctrl P04: V/F control P07: HMI P08: Enhanced Function | | | | | | | | | | | | | | | | | | | | | | | | | | | | | | | | | | | | | | | | | | | | | | |
| Return | | Homepage | | Select | | | | | | | | | | | | | | | | | | | | | | | | | | | | | | | | | | | | | | | | | | |
| 16:02:35 | Fwd | Local | Ready | GD28 | | | | | | | | | | | | | | | | | | | | | | | | | | | | | | | | | | | | | | | | | | |
| P01.00: Start mode | | | | | | | | | | | | | | | | | | | | | | | | | | | | | | | | | | | | | | | | | | | | | | |
| P01.01: DirectStart Freq P01.02: StartFreq HoldTime P01.03: Prestart BrakeCur P01.04: Prestart BrakeTime P01.05: ACC/DEC Mode | | | | | | | | | | | | | | | | | | | | | | | | | | | | | | | | | | | | | | | | | | | | | | |
| Return | | Add | | Select | | | | | | | | | | | | | | | | | | | | | | | | | | | | | | | | | | | | | | | | | | |
| <p>Step 5 Press the key for confirmation.</p> | <p>Step 6 After the page returns to the current function code group, continue adding function codes or return to the previous menu.</p> | | | | | | | | | | | | | | | | | | | | | | | | | | | | | | | | | | | | | | | | | | | | | |

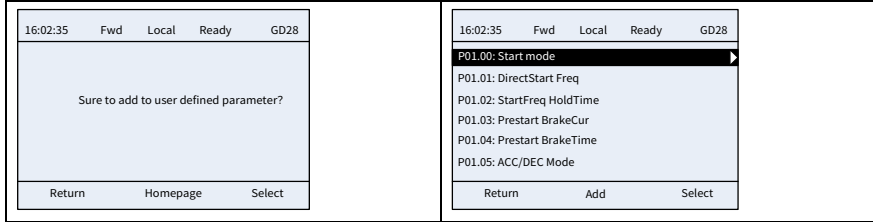

5.4.3.4 Modifying parameters

You can quickly modify the parameter value through **Parameters** on the homepage in the stopped/running state, or through **Menu > Grouping Parameters** or **User defined parameter setting**.

In parameter value modification interface, **Authority** on the top right indicates whether the parameter can be modified.





"√": It indicates that the value of the parameter can be modified under current VFD state.

"×": It indicates that the value of the parameter cannot be modified under current VFD state.

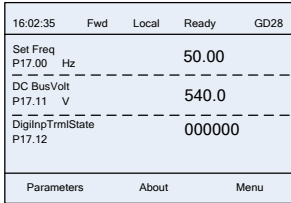
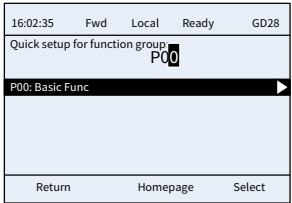
Quick parameter modification

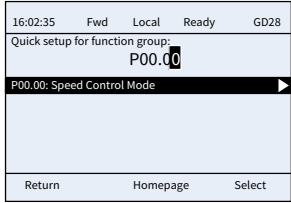
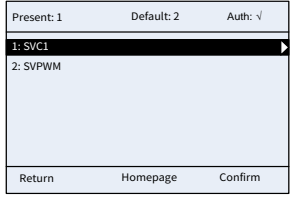

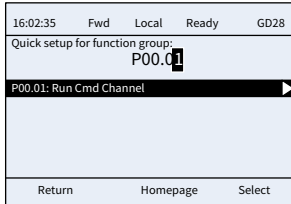

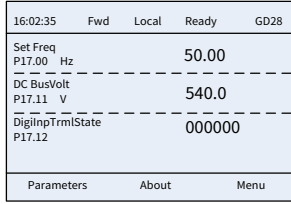



















The operation example is as follows:

| | |
|--|--|
| <p>Step 1 In the stopped state homepage, press the key corresponding to Parameters to select the menu item.</p> | <p>Step 2 Press or to select a function code group; press the key corresponding to Select to keep the current selection.</p> |
|  |  |
| <p>Step 3 Press or to select a function code; press the key corresponding to Select to keep the current selection.</p> | <p>Step 4 Press or to change the value.</p> |

| | |
|--|---|
|  <p>16:02:35 Fwd Local Ready GD28</p> <p>Quick setup for function group: P00.00</p> <p>P00.00: Speed Control Mode</p> <p>Return Homepage Select</p> |  <p>Present: 1 Default: 2 Auth: √</p> <p>1: SVC1</p> <p>2: SVPWM</p> <p>Return Homepage Confirm</p> <p>Press the key  corresponding to Confirm. The page returns to the current group function code list. You can continue with the modification or to return to the previous menu.</p> |
| <p>Step5 Press the key  to confirm. The page goes to the next function code.</p>  <p>16:02:35 Fwd Local Ready GD28</p> <p>Quick setup for function group: P00.01</p> <p>P00.01: Run Cmd Channel</p> <p>Return Homepage Select</p> | <p>Step6 Repeating the preceding steps to modify other parameters, or press the key  corresponding to Return to return to previous menu, or press the key  corresponding to Homepage to go to the homepage.</p>  <p>16:02:35 Fwd Local Ready GD28</p> <p>Set Freq P17.00 Hz 50.00</p> <p>DC BusVolt P17.11 V 540.0</p> <p>DigInpTrmlState P17.12 000000</p> <p>Parameters About Menu</p> |



















Grouping parameters

The operation example is as follows:

| | | | | | | | | | | | | | | | | | | | | | | | | | | | | | | | | | | | | | | | | | | | | | | | | | | | | | | | | | | | | | | | | | | | | | | | | | | | | | | | | | |
|--|---|---------|-----------------|---|-------------|---|-------------|-------|----------------|--|-----------------------------------|---|--|----------|-----|---------------------------|-------|--------|----------------------------|--|---------------------------------|--|--|-------------------------|--|--|----------|-----|--------------------------|-------|------------------------|---|--|---|--|----------------------------------|--------------------------------|--|--------------------------|--|--|------------------|-----|---------------------------|-------|------|----------------------------|--|-----------------------------|--|--|----------------------------------|--|--|--|--|--------------------------|--|--|--|--|---|--|--|--|--|--------------------------|--|--|--|--|---------------------------|--|--|--|--|-----------------------------|--|--|--|--|
| <p>Step 1 In the stopped state homepage, press the key  corresponding to Menu to select the menu item.</p> <table border="1" style="width: 100%; border-collapse: collapse; margin-top: 10px;"> <tr> <td style="font-size: small;">16:02:35</td> <td style="font-size: small;">Fwd</td> <td style="font-size: small;">Local</td> <td style="font-size: small;">Ready</td> <td style="font-size: small;">GD28</td> </tr> <tr> <td>Set Freq P17.00</td> <td>Hz</td> <td colspan="3" style="text-align: center;">50.00</td> </tr> <tr> <td>DC BusVolt P17.11</td> <td>V</td> <td colspan="3" style="text-align: center;">540.0</td> </tr> <tr> <td>DigInpTrmlState P17.12</td> <td></td> <td colspan="3" style="text-align: center;">000000</td> </tr> <tr> <td colspan="5" style="text-align: center;">Parameters About Menu</td> </tr> </table> | 16:02:35 | Fwd | Local | Ready | GD28 | Set Freq P17.00 | Hz | 50.00 | | | DC BusVolt P17.11 | V | 540.0 | | | DigInpTrmlState P17.12 | | 000000 | | | Parameters About Menu | | | | | <p>Step 2 Select Grouping parameters and press  to confirm.</p> <table border="1" style="width: 100%; border-collapse: collapse; margin-top: 10px;"> <tr> <td style="font-size: small;">16:02:35</td> <td style="font-size: small;">Fwd</td> <td style="font-size: small;">Local</td> <td style="font-size: small;">Ready</td> <td style="font-size: small;">GD28</td> </tr> <tr> <td colspan="5" style="text-align: center;">Grouping parameters </td> </tr> <tr> <td colspan="5" style="font-size: x-small;">User defined parameter setting</td> </tr> <tr> <td colspan="5" style="font-size: x-small;">State monitoring</td> </tr> <tr> <td colspan="5" style="font-size: x-small;">Motor parameter autotuning</td> </tr> <tr> <td colspan="5" style="font-size: x-small;">Parameter backup/Restore default</td> </tr> <tr> <td colspan="5" style="font-size: x-small;">System setting</td> </tr> <tr> <td colspan="5" style="text-align: center;">Return Homepage Select</td> </tr> </table> | 16:02:35 | Fwd | Local | Ready | GD28 | Grouping parameters  | | | | | User defined parameter setting | | | | | State monitoring | | | | | Motor parameter autotuning | | | | | Parameter backup/Restore default | | | | | System setting | | | | | Return Homepage Select | | | | | | | | | | | | | | | | | | | |
| 16:02:35 | Fwd | Local | Ready | GD28 | | | | | | | | | | | | | | | | | | | | | | | | | | | | | | | | | | | | | | | | | | | | | | | | | | | | | | | | | | | | | | | | | | | | | | | | | | | | | |
| Set Freq P17.00 | Hz | 50.00 | | | | | | | | | | | | | | | | | | | | | | | | | | | | | | | | | | | | | | | | | | | | | | | | | | | | | | | | | | | | | | | | | | | | | | | | | | | | | | | |
| DC BusVolt P17.11 | V | 540.0 | | | | | | | | | | | | | | | | | | | | | | | | | | | | | | | | | | | | | | | | | | | | | | | | | | | | | | | | | | | | | | | | | | | | | | | | | | | | | | | |
| DigInpTrmlState P17.12 | | 000000 | | | | | | | | | | | | | | | | | | | | | | | | | | | | | | | | | | | | | | | | | | | | | | | | | | | | | | | | | | | | | | | | | | | | | | | | | | | | | | | |
| Parameters About Menu | | | | | | | | | | | | | | | | | | | | | | | | | | | | | | | | | | | | | | | | | | | | | | | | | | | | | | | | | | | | | | | | | | | | | | | | | | | | | | | | | |
| 16:02:35 | Fwd | Local | Ready | GD28 | | | | | | | | | | | | | | | | | | | | | | | | | | | | | | | | | | | | | | | | | | | | | | | | | | | | | | | | | | | | | | | | | | | | | | | | | | | | | |
| Grouping parameters  | | | | | | | | | | | | | | | | | | | | | | | | | | | | | | | | | | | | | | | | | | | | | | | | | | | | | | | | | | | | | | | | | | | | | | | | | | | | | | | | | |
| User defined parameter setting | | | | | | | | | | | | | | | | | | | | | | | | | | | | | | | | | | | | | | | | | | | | | | | | | | | | | | | | | | | | | | | | | | | | | | | | | | | | | | | | | |
| State monitoring | | | | | | | | | | | | | | | | | | | | | | | | | | | | | | | | | | | | | | | | | | | | | | | | | | | | | | | | | | | | | | | | | | | | | | | | | | | | | | | | | |
| Motor parameter autotuning | | | | | | | | | | | | | | | | | | | | | | | | | | | | | | | | | | | | | | | | | | | | | | | | | | | | | | | | | | | | | | | | | | | | | | | | | | | | | | | | | |
| Parameter backup/Restore default | | | | | | | | | | | | | | | | | | | | | | | | | | | | | | | | | | | | | | | | | | | | | | | | | | | | | | | | | | | | | | | | | | | | | | | | | | | | | | | | | |
| System setting | | | | | | | | | | | | | | | | | | | | | | | | | | | | | | | | | | | | | | | | | | | | | | | | | | | | | | | | | | | | | | | | | | | | | | | | | | | | | | | | | |
| Return Homepage Select | | | | | | | | | | | | | | | | | | | | | | | | | | | | | | | | | | | | | | | | | | | | | | | | | | | | | | | | | | | | | | | | | | | | | | | | | | | | | | | | | |
| <p>Step 3 Select Basic parameters, and press  to select function code group P00.</p> <table border="1" style="width: 100%; border-collapse: collapse; margin-top: 10px;"> <tr> <td style="font-size: small;">16:02:35</td> <td style="font-size: small;">Fwd</td> <td style="font-size: small;">Local</td> <td style="font-size: small;">Ready</td> <td style="font-size: small;">GD28</td> </tr> <tr> <td colspan="5" style="text-align: center;">P00: Basic Func </td> </tr> <tr> <td colspan="5" style="font-size: x-small;">P01: Start/stop Control</td> </tr> <tr> <td colspan="5" style="font-size: x-small;">P03: Motor 1 Vector Ctrl</td> </tr> <tr> <td colspan="5" style="font-size: x-small;">P04: V/F Control</td> </tr> <tr> <td colspan="5" style="font-size: x-small;">P07: HMI</td> </tr> <tr> <td colspan="5" style="font-size: x-small;">P08: Enhanced Function</td> </tr> <tr> <td colspan="5" style="text-align: center;">Return Homepage Select</td> </tr> </table> | 16:02:35 | Fwd | Local | Ready | GD28 | P00: Basic Func  | | | | | P01: Start/stop Control | | | | | P03: Motor 1 Vector Ctrl | | | | | P04: V/F Control | | | | | P07: HMI | | | | | P08: Enhanced Function | | | | | Return Homepage Select | | | | | <p>Step 4 Press  to select a function code, and press  to confirm.</p> <table border="1" style="width: 100%; border-collapse: collapse; margin-top: 10px;"> <tr> <td style="font-size: small;">16:02:35</td> <td style="font-size: small;">Fwd</td> <td style="font-size: small;">Local</td> <td style="font-size: small;">Ready</td> <td style="font-size: small;">GD28</td> </tr> <tr> <td colspan="5" style="font-size: x-small;">P00.00: Speed Control Mode</td> </tr> <tr> <td colspan="5" style="font-size: x-small;">P00.01: Run Cmd Channel</td> </tr> <tr> <td colspan="5" style="font-size: x-small;">P00.02: Comm Cmd Channel</td> </tr> <tr> <td colspan="5" style="text-align: center;">P00.03: Max Output Freq </td> </tr> <tr> <td colspan="5" style="font-size: x-small;">P00.04: RunFreq Up limit</td> </tr> <tr> <td colspan="5" style="font-size: x-small;">P00.05: RunFreq Low limit</td> </tr> <tr> <td colspan="5" style="text-align: center;">Return Add Select</td> </tr> </table> | 16:02:35 | Fwd | Local | Ready | GD28 | P00.00: Speed Control Mode | | | | | P00.01: Run Cmd Channel | | | | | P00.02: Comm Cmd Channel | | | | | P00.03: Max Output Freq  | | | | | P00.04: RunFreq Up limit | | | | | P00.05: RunFreq Low limit | | | | | Return Add Select | | | | |
| 16:02:35 | Fwd | Local | Ready | GD28 | | | | | | | | | | | | | | | | | | | | | | | | | | | | | | | | | | | | | | | | | | | | | | | | | | | | | | | | | | | | | | | | | | | | | | | | | | | | | |
| P00: Basic Func  | | | | | | | | | | | | | | | | | | | | | | | | | | | | | | | | | | | | | | | | | | | | | | | | | | | | | | | | | | | | | | | | | | | | | | | | | | | | | | | | | |
| P01: Start/stop Control | | | | | | | | | | | | | | | | | | | | | | | | | | | | | | | | | | | | | | | | | | | | | | | | | | | | | | | | | | | | | | | | | | | | | | | | | | | | | | | | | |
| P03: Motor 1 Vector Ctrl | | | | | | | | | | | | | | | | | | | | | | | | | | | | | | | | | | | | | | | | | | | | | | | | | | | | | | | | | | | | | | | | | | | | | | | | | | | | | | | | | |
| P04: V/F Control | | | | | | | | | | | | | | | | | | | | | | | | | | | | | | | | | | | | | | | | | | | | | | | | | | | | | | | | | | | | | | | | | | | | | | | | | | | | | | | | | |
| P07: HMI | | | | | | | | | | | | | | | | | | | | | | | | | | | | | | | | | | | | | | | | | | | | | | | | | | | | | | | | | | | | | | | | | | | | | | | | | | | | | | | | | |
| P08: Enhanced Function | | | | | | | | | | | | | | | | | | | | | | | | | | | | | | | | | | | | | | | | | | | | | | | | | | | | | | | | | | | | | | | | | | | | | | | | | | | | | | | | | |
| Return Homepage Select | | | | | | | | | | | | | | | | | | | | | | | | | | | | | | | | | | | | | | | | | | | | | | | | | | | | | | | | | | | | | | | | | | | | | | | | | | | | | | | | | |
| 16:02:35 | Fwd | Local | Ready | GD28 | | | | | | | | | | | | | | | | | | | | | | | | | | | | | | | | | | | | | | | | | | | | | | | | | | | | | | | | | | | | | | | | | | | | | | | | | | | | | |
| P00.00: Speed Control Mode | | | | | | | | | | | | | | | | | | | | | | | | | | | | | | | | | | | | | | | | | | | | | | | | | | | | | | | | | | | | | | | | | | | | | | | | | | | | | | | | | |
| P00.01: Run Cmd Channel | | | | | | | | | | | | | | | | | | | | | | | | | | | | | | | | | | | | | | | | | | | | | | | | | | | | | | | | | | | | | | | | | | | | | | | | | | | | | | | | | |
| P00.02: Comm Cmd Channel | | | | | | | | | | | | | | | | | | | | | | | | | | | | | | | | | | | | | | | | | | | | | | | | | | | | | | | | | | | | | | | | | | | | | | | | | | | | | | | | | |
| P00.03: Max Output Freq  | | | | | | | | | | | | | | | | | | | | | | | | | | | | | | | | | | | | | | | | | | | | | | | | | | | | | | | | | | | | | | | | | | | | | | | | | | | | | | | | | |
| P00.04: RunFreq Up limit | | | | | | | | | | | | | | | | | | | | | | | | | | | | | | | | | | | | | | | | | | | | | | | | | | | | | | | | | | | | | | | | | | | | | | | | | | | | | | | | | |
| P00.05: RunFreq Low limit | | | | | | | | | | | | | | | | | | | | | | | | | | | | | | | | | | | | | | | | | | | | | | | | | | | | | | | | | | | | | | | | | | | | | | | | | | | | | | | | | |
| Return Add Select | | | | | | | | | | | | | | | | | | | | | | | | | | | | | | | | | | | | | | | | | | | | | | | | | | | | | | | | | | | | | | | | | | | | | | | | | | | | | | | | | |
| <p>Step 5 Press  or  to increase or decrease the value.</p> <table border="1" style="width: 100%; border-collapse: collapse; margin-top: 10px;"> <tr> <td style="font-size: x-small;">Present: 50.00</td> <td style="font-size: x-small;">Auth: √</td> </tr> <tr> <td>Max. OutputFreq</td> <td style="text-align: center;">050.0 </td> </tr> <tr> <td>Max: 630.00</td> <td></td> </tr> <tr> <td>Min.: 50.00</td> <td></td> </tr> <tr> <td>Default: 50.00</td> <td></td> </tr> <tr> <td colspan="2" style="text-align: center;">Return Homepage Confirm</td> </tr> </table> | Present: 50.00 | Auth: √ | Max. OutputFreq | 050.0  | Max: 630.00 | | Min.: 50.00 | | Default: 50.00 | | Return Homepage Confirm | | <p>Step 6 Press the key  corresponding to Confirm. The page returns to the current group function code list. You can continue with the modification or  to return to the previous menu.</p> <table border="1" style="width: 100%; border-collapse: collapse; margin-top: 10px;"> <tr> <td style="font-size: small;">16:02:35</td> <td style="font-size: small;">Fwd</td> <td style="font-size: small;">Local</td> <td style="font-size: small;">Ready</td> <td style="font-size: small;">GD28</td> </tr> <tr> <td colspan="5" style="font-size: x-small;">P00.00: Speed Control Mode</td> </tr> <tr> <td colspan="5" style="font-size: x-small;">P00.01: Run Cmd Channel</td> </tr> <tr> <td colspan="5" style="font-size: x-small;">P00.02: Comm Cmd Channel</td> </tr> <tr> <td colspan="5" style="text-align: center;">P00.03: Max Output Freq </td> </tr> <tr> <td colspan="5" style="font-size: x-small;">P00.04: RunFreq Up limit</td> </tr> <tr> <td colspan="5" style="font-size: x-small;">P00.05: RunFreq Low limit</td> </tr> <tr> <td colspan="5" style="text-align: center;">Return Add Select</td> </tr> </table> | 16:02:35 | Fwd | Local | Ready | GD28 | P00.00: Speed Control Mode | | | | | P00.01: Run Cmd Channel | | | | | P00.02: Comm Cmd Channel | | | | | P00.03: Max Output Freq  | | | | | P00.04: RunFreq Up limit | | | | | P00.05: RunFreq Low limit | | | | | Return Add Select | | | | | | | | | | | | | | | | | | | | | | | | | | | | | | | | |
| Present: 50.00 | Auth: √ | | | | | | | | | | | | | | | | | | | | | | | | | | | | | | | | | | | | | | | | | | | | | | | | | | | | | | | | | | | | | | | | | | | | | | | | | | | | | | | | |
| Max. OutputFreq | 050.0  | | | | | | | | | | | | | | | | | | | | | | | | | | | | | | | | | | | | | | | | | | | | | | | | | | | | | | | | | | | | | | | | | | | | | | | | | | | | | | | | |
| Max: 630.00 | | | | | | | | | | | | | | | | | | | | | | | | | | | | | | | | | | | | | | | | | | | | | | | | | | | | | | | | | | | | | | | | | | | | | | | | | | | | | | | | | |
| Min.: 50.00 | | | | | | | | | | | | | | | | | | | | | | | | | | | | | | | | | | | | | | | | | | | | | | | | | | | | | | | | | | | | | | | | | | | | | | | | | | | | | | | | | |
| Default: 50.00 | | | | | | | | | | | | | | | | | | | | | | | | | | | | | | | | | | | | | | | | | | | | | | | | | | | | | | | | | | | | | | | | | | | | | | | | | | | | | | | | | |
| Return Homepage Confirm | | | | | | | | | | | | | | | | | | | | | | | | | | | | | | | | | | | | | | | | | | | | | | | | | | | | | | | | | | | | | | | | | | | | | | | | | | | | | | | | | |
| 16:02:35 | Fwd | Local | Ready | GD28 | | | | | | | | | | | | | | | | | | | | | | | | | | | | | | | | | | | | | | | | | | | | | | | | | | | | | | | | | | | | | | | | | | | | | | | | | | | | | |
| P00.00: Speed Control Mode | | | | | | | | | | | | | | | | | | | | | | | | | | | | | | | | | | | | | | | | | | | | | | | | | | | | | | | | | | | | | | | | | | | | | | | | | | | | | | | | | |
| P00.01: Run Cmd Channel | | | | | | | | | | | | | | | | | | | | | | | | | | | | | | | | | | | | | | | | | | | | | | | | | | | | | | | | | | | | | | | | | | | | | | | | | | | | | | | | | |
| P00.02: Comm Cmd Channel | | | | | | | | | | | | | | | | | | | | | | | | | | | | | | | | | | | | | | | | | | | | | | | | | | | | | | | | | | | | | | | | | | | | | | | | | | | | | | | | | |
| P00.03: Max Output Freq  | | | | | | | | | | | | | | | | | | | | | | | | | | | | | | | | | | | | | | | | | | | | | | | | | | | | | | | | | | | | | | | | | | | | | | | | | | | | | | | | | |
| P00.04: RunFreq Up limit | | | | | | | | | | | | | | | | | | | | | | | | | | | | | | | | | | | | | | | | | | | | | | | | | | | | | | | | | | | | | | | | | | | | | | | | | | | | | | | | | |
| P00.05: RunFreq Low limit | | | | | | | | | | | | | | | | | | | | | | | | | | | | | | | | | | | | | | | | | | | | | | | | | | | | | | | | | | | | | | | | | | | | | | | | | | | | | | | | | |
| Return Add Select | | | | | | | | | | | | | | | | | | | | | | | | | | | | | | | | | | | | | | | | | | | | | | | | | | | | | | | | | | | | | | | | | | | | | | | | | | | | | | | | | |

User defined parameter setting



The operation example is as follows:

| | | | | | | | | | | | | | | | | | | | | | | | | | | | | | | | | | | | | | | | | | | | | | | | | | | | | | | | | | | | | | | | | | | |
|---|------------|----------|-------|-------|-------|--|---|-------|--|--|-------------------------|-------------------------|-------|--|--|--------------------------|--------------------------|--------|--|--|---------------------------------|-------------------------|--|--|--|---|--------------------------|-----|-------|-------|---------------------------|---------------------------|--|--|--|-----------------------------|--|--|--|--|--|------------------|------------|---------|--|--|----------------------------|---------|--|--|----------|----------------------------------|--|-----------------------------------|--|--|----------------|--|--|--|--|----------------------------------|--|--|--|--|
| <p>Step 1 In the stopped state homepage, press the key  corresponding to Menu to select the menu item.</p> <table border="1" style="width: 100%; border-collapse: collapse; margin-top: 10px;"> <tr> <td style="font-size: small;">16:02:35</td> <td style="font-size: small;">Fwd</td> <td style="font-size: small;">Local</td> <td style="font-size: small;">Ready</td> <td style="font-size: small;">GD28</td> </tr> <tr> <td>Set Freq P17.00</td> <td>Hz</td> <td colspan="3" style="text-align: right;">50.00</td> </tr> <tr> <td>DC BusVolt P17.11</td> <td>V</td> <td colspan="3" style="text-align: right;">540.0</td> </tr> <tr> <td>DigInPrmIState P17.12</td> <td></td> <td colspan="3" style="text-align: right;">000000</td> </tr> <tr> <td colspan="5" style="text-align: center; font-size: small;">Parameters About Menu</td> </tr> </table> | 16:02:35 | Fwd | Local | Ready | GD28 | Set Freq P17.00 | Hz | 50.00 | | | DC BusVolt P17.11 | V | 540.0 | | | DigInPrmIState P17.12 | | 000000 | | | Parameters About Menu | | | | | <p>Step 2 Press  to select User defined parameter setting, and press  to confirm.</p> <table border="1" style="width: 100%; border-collapse: collapse; margin-top: 10px;"> <tr> <td style="font-size: small;">16:02:35</td> <td style="font-size: small;">Fwd</td> <td style="font-size: small;">Local</td> <td style="font-size: small;">Ready</td> <td style="font-size: small;">GD28</td> </tr> <tr> <td colspan="5" style="font-size: small;">Grouping parameters</td> </tr> <tr> <td colspan="5" style="font-size: small;">User defined parameter setting </td> </tr> <tr> <td colspan="5" style="font-size: small;">State monitoring</td> </tr> <tr> <td colspan="5" style="font-size: small;">Motor parameter autotuning</td> </tr> <tr> <td colspan="5" style="font-size: small;">Parameter backup/Restore default</td> </tr> <tr> <td colspan="5" style="font-size: small;">System setting</td> </tr> <tr> <td colspan="5" style="text-align: center; font-size: small;">Return Homepage Select</td> </tr> </table> | 16:02:35 | Fwd | Local | Ready | GD28 | Grouping parameters | | | | | User defined parameter setting  | | | | | State monitoring | | | | | Motor parameter autotuning | | | | | Parameter backup/Restore default | | | | | System setting | | | | | Return Homepage Select | | | | |
| 16:02:35 | Fwd | Local | Ready | GD28 | | | | | | | | | | | | | | | | | | | | | | | | | | | | | | | | | | | | | | | | | | | | | | | | | | | | | | | | | | | | | | |
| Set Freq P17.00 | Hz | 50.00 | | | | | | | | | | | | | | | | | | | | | | | | | | | | | | | | | | | | | | | | | | | | | | | | | | | | | | | | | | | | | | | | |
| DC BusVolt P17.11 | V | 540.0 | | | | | | | | | | | | | | | | | | | | | | | | | | | | | | | | | | | | | | | | | | | | | | | | | | | | | | | | | | | | | | | | |
| DigInPrmIState P17.12 | | 000000 | | | | | | | | | | | | | | | | | | | | | | | | | | | | | | | | | | | | | | | | | | | | | | | | | | | | | | | | | | | | | | | | |
| Parameters About Menu | | | | | | | | | | | | | | | | | | | | | | | | | | | | | | | | | | | | | | | | | | | | | | | | | | | | | | | | | | | | | | | | | | |
| 16:02:35 | Fwd | Local | Ready | GD28 | | | | | | | | | | | | | | | | | | | | | | | | | | | | | | | | | | | | | | | | | | | | | | | | | | | | | | | | | | | | | | |
| Grouping parameters | | | | | | | | | | | | | | | | | | | | | | | | | | | | | | | | | | | | | | | | | | | | | | | | | | | | | | | | | | | | | | | | | | |
| User defined parameter setting  | | | | | | | | | | | | | | | | | | | | | | | | | | | | | | | | | | | | | | | | | | | | | | | | | | | | | | | | | | | | | | | | | | |
| State monitoring | | | | | | | | | | | | | | | | | | | | | | | | | | | | | | | | | | | | | | | | | | | | | | | | | | | | | | | | | | | | | | | | | | |
| Motor parameter autotuning | | | | | | | | | | | | | | | | | | | | | | | | | | | | | | | | | | | | | | | | | | | | | | | | | | | | | | | | | | | | | | | | | | |
| Parameter backup/Restore default | | | | | | | | | | | | | | | | | | | | | | | | | | | | | | | | | | | | | | | | | | | | | | | | | | | | | | | | | | | | | | | | | | |
| System setting | | | | | | | | | | | | | | | | | | | | | | | | | | | | | | | | | | | | | | | | | | | | | | | | | | | | | | | | | | | | | | | | | | |
| Return Homepage Select | | | | | | | | | | | | | | | | | | | | | | | | | | | | | | | | | | | | | | | | | | | | | | | | | | | | | | | | | | | | | | | | | | |
| <p>Step 3 Press the key  corresponding to Select.</p> <table border="1" style="width: 100%; border-collapse: collapse; margin-top: 10px;"> <tr> <td style="font-size: small;">16:02:35</td> <td style="font-size: small;">Fwd</td> <td style="font-size: small;">Local</td> <td style="font-size: small;">Ready</td> <td style="font-size: small;">GD28</td> </tr> <tr> <td colspan="5" style="font-size: small;">P00.00: Speed Control Mode </td> </tr> <tr> <td colspan="5" style="font-size: small;">P00.01: Run Cmd Channel</td> </tr> <tr> <td colspan="5" style="font-size: small;">P00.02: Comm Cmd Channel</td> </tr> <tr> <td colspan="5" style="font-size: small;">P00.03: Max Output Freq</td> </tr> <tr> <td colspan="5" style="font-size: small;">P00.04: RunFreq Up limit</td> </tr> <tr> <td colspan="5" style="font-size: small;">P00.05: RunFreq Low limit</td> </tr> <tr> <td colspan="5" style="text-align: center; font-size: small;">Return Add Select</td> </tr> </table> | 16:02:35 | Fwd | Local | Ready | GD28 | P00.00: Speed Control Mode  | | | | | P00.01: Run Cmd Channel | | | | | P00.02: Comm Cmd Channel | | | | | P00.03: Max Output Freq | | | | | P00.04: RunFreq Up limit | | | | | P00.05: RunFreq Low limit | | | | | Return Add Select | | | | | <p>Step 4 Press  or  to change the value.</p> <table border="1" style="width: 100%; border-collapse: collapse; margin-top: 10px;"> <tr> <td style="font-size: small;">Present: 0</td> <td style="font-size: small;">Default: 2</td> <td style="font-size: small;">Auth: √</td> </tr> <tr> <td colspan="3" style="font-size: small;">0: SVC 0 </td> </tr> <tr> <td colspan="3" style="font-size: small;">1: SVC1</td> </tr> <tr> <td colspan="3" style="font-size: small;">2: SVPWM</td> </tr> <tr> <td colspan="3" style="text-align: center; font-size: small;">Return Homepage Confirm</td> </tr> </table> | Present: 0 | Default: 2 | Auth: √ | 0: SVC 0  | | | 1: SVC1 | | | 2: SVPWM | | | Return Homepage Confirm | | | | | | | | | | | | |
| 16:02:35 | Fwd | Local | Ready | GD28 | | | | | | | | | | | | | | | | | | | | | | | | | | | | | | | | | | | | | | | | | | | | | | | | | | | | | | | | | | | | | | |
| P00.00: Speed Control Mode  | | | | | | | | | | | | | | | | | | | | | | | | | | | | | | | | | | | | | | | | | | | | | | | | | | | | | | | | | | | | | | | | | | |
| P00.01: Run Cmd Channel | | | | | | | | | | | | | | | | | | | | | | | | | | | | | | | | | | | | | | | | | | | | | | | | | | | | | | | | | | | | | | | | | | |
| P00.02: Comm Cmd Channel | | | | | | | | | | | | | | | | | | | | | | | | | | | | | | | | | | | | | | | | | | | | | | | | | | | | | | | | | | | | | | | | | | |
| P00.03: Max Output Freq | | | | | | | | | | | | | | | | | | | | | | | | | | | | | | | | | | | | | | | | | | | | | | | | | | | | | | | | | | | | | | | | | | |
| P00.04: RunFreq Up limit | | | | | | | | | | | | | | | | | | | | | | | | | | | | | | | | | | | | | | | | | | | | | | | | | | | | | | | | | | | | | | | | | | |
| P00.05: RunFreq Low limit | | | | | | | | | | | | | | | | | | | | | | | | | | | | | | | | | | | | | | | | | | | | | | | | | | | | | | | | | | | | | | | | | | |
| Return Add Select | | | | | | | | | | | | | | | | | | | | | | | | | | | | | | | | | | | | | | | | | | | | | | | | | | | | | | | | | | | | | | | | | | |
| Present: 0 | Default: 2 | Auth: √ | | | | | | | | | | | | | | | | | | | | | | | | | | | | | | | | | | | | | | | | | | | | | | | | | | | | | | | | | | | | | | | | |
| 0: SVC 0  | | | | | | | | | | | | | | | | | | | | | | | | | | | | | | | | | | | | | | | | | | | | | | | | | | | | | | | | | | | | | | | | | | |
| 1: SVC1 | | | | | | | | | | | | | | | | | | | | | | | | | | | | | | | | | | | | | | | | | | | | | | | | | | | | | | | | | | | | | | | | | | |
| 2: SVPWM | | | | | | | | | | | | | | | | | | | | | | | | | | | | | | | | | | | | | | | | | | | | | | | | | | | | | | | | | | | | | | | | | | |
| Return Homepage Confirm | | | | | | | | | | | | | | | | | | | | | | | | | | | | | | | | | | | | | | | | | | | | | | | | | | | | | | | | | | | | | | | | | | |
| <p>Step 5 Press the key  to confirm. The page returns to the user defined parameter list, and you can continue to modify parameters or return to the previous menu.</p> <table border="1" style="width: 100%; border-collapse: collapse; margin-top: 10px;"> <tr> <td style="font-size: small;">16:02:35</td> <td style="font-size: small;">Fwd</td> <td style="font-size: small;">Local</td> <td style="font-size: small;">Ready</td> <td style="font-size: small;">GD28</td> </tr> <tr> <td colspan="5" style="font-size: small;">P00.00: Speed Control Mode </td> </tr> <tr> <td colspan="5" style="font-size: small;">P00.01: Run Cmd Channel</td> </tr> <tr> <td colspan="5" style="font-size: small;">P00.02: Comm Cmd Channel</td> </tr> <tr> <td colspan="5" style="font-size: small;">P00.03: Max Output Freq</td> </tr> <tr> <td colspan="5" style="font-size: small;">P00.04: RunFreq Up limit</td> </tr> <tr> <td colspan="5" style="font-size: small;">P00.05: RunFreq Low limit</td> </tr> <tr> <td colspan="5" style="text-align: center; font-size: small;">Return Add Select</td> </tr> </table> | | 16:02:35 | Fwd | Local | Ready | GD28 | P00.00: Speed Control Mode  | | | | | P00.01: Run Cmd Channel | | | | | P00.02: Comm Cmd Channel | | | | | P00.03: Max Output Freq | | | | | P00.04: RunFreq Up limit | | | | | P00.05: RunFreq Low limit | | | | | Return Add Select | | | | | | | | | | | | | | | | | | | | | | | | | | | | | |
| 16:02:35 | Fwd | Local | Ready | GD28 | | | | | | | | | | | | | | | | | | | | | | | | | | | | | | | | | | | | | | | | | | | | | | | | | | | | | | | | | | | | | | |
| P00.00: Speed Control Mode  | | | | | | | | | | | | | | | | | | | | | | | | | | | | | | | | | | | | | | | | | | | | | | | | | | | | | | | | | | | | | | | | | | |
| P00.01: Run Cmd Channel | | | | | | | | | | | | | | | | | | | | | | | | | | | | | | | | | | | | | | | | | | | | | | | | | | | | | | | | | | | | | | | | | | |
| P00.02: Comm Cmd Channel | | | | | | | | | | | | | | | | | | | | | | | | | | | | | | | | | | | | | | | | | | | | | | | | | | | | | | | | | | | | | | | | | | |
| P00.03: Max Output Freq | | | | | | | | | | | | | | | | | | | | | | | | | | | | | | | | | | | | | | | | | | | | | | | | | | | | | | | | | | | | | | | | | | |
| P00.04: RunFreq Up limit | | | | | | | | | | | | | | | | | | | | | | | | | | | | | | | | | | | | | | | | | | | | | | | | | | | | | | | | | | | | | | | | | | |
| P00.05: RunFreq Low limit | | | | | | | | | | | | | | | | | | | | | | | | | | | | | | | | | | | | | | | | | | | | | | | | | | | | | | | | | | | | | | | | | | |
| Return Add Select | | | | | | | | | | | | | | | | | | | | | | | | | | | | | | | | | | | | | | | | | | | | | | | | | | | | | | | | | | | | | | | | | | |

5.4.3.5 Viewing parameters

You can know the VFD state through viewing related parameters.

The operation example is as follows:







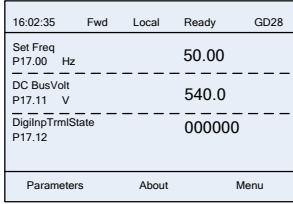
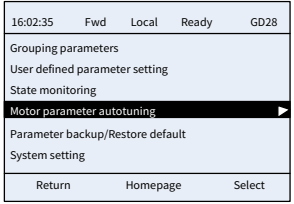

| | |
|---|--|
| <p>Step 1 In the stopped state homepage, press the key  corresponding to Menu to select the menu item.</p> | <p>Step 2 Press  to select State monitoring and press  to confirm.</p> |
|---|--|

| | | | | | | | | | | | | | | | | | | | | | | | | | | | | | | | | | | | | | | | | | | | | | | | | | | | | | | | | | | | | | | | | | | | | | | | | | | | | |
|--|----------|-------|--------|-------|------|----------------------------|--------|----|-------|--|---------------------|--------|---|-------|--|----------------------|--------|--|--------|--|--|--|--|--|--|---|----------|-----|-------|-------|------------------------------|---------------------|--|--|--|---|--------------------------------|--|--|--|---|------------------|-----|-------|-------|------|----------------------------|--|--|-------|----|----------------------------------|--|--|--|--|-------------------------|--|--|--|--|---|--|--|--|--|--|--|--|--|--|---|--|--|--|--|
| <table border="1" style="width: 100%; border-collapse: collapse;"> <tr> <td style="font-size: small;">16:02:35</td> <td style="font-size: small;">Fwd</td> <td style="font-size: small;">Local</td> <td style="font-size: small;">Ready</td> <td style="font-size: small;">GD28</td> </tr> <tr> <td>Set Freq</td> <td>P17.00</td> <td>Hz</td> <td>50.00</td> <td></td> </tr> <tr> <td>DC BusVolt</td> <td>P17.11</td> <td>V</td> <td>540.0</td> <td></td> </tr> <tr> <td>DigInpTrmlState</td> <td>P17.12</td> <td></td> <td>000000</td> <td></td> </tr> <tr> <td colspan="5" style="text-align: center; border-top: 1px dashed black;"> Parameters About Menu </td> </tr> </table> | 16:02:35 | Fwd | Local | Ready | GD28 | Set Freq | P17.00 | Hz | 50.00 | | DC BusVolt | P17.11 | V | 540.0 | | DigInpTrmlState | P17.12 | | 000000 | | Parameters About Menu | | | | | <table border="1" style="width: 100%; border-collapse: collapse;"> <tr> <td style="font-size: small;">16:02:35</td> <td style="font-size: small;">Fwd</td> <td style="font-size: small;">Local</td> <td style="font-size: small;">Ready</td> <td style="font-size: small;">GD28</td> </tr> <tr> <td colspan="5">Grouping parameters</td> </tr> <tr> <td colspan="5">User defined parameter setting</td> </tr> <tr> <td colspan="5" style="background-color: #e0e0e0;">State monitoring</td> </tr> <tr> <td colspan="5">Motor parameter autotuning</td> </tr> <tr> <td colspan="5">Parameter backup/Restore default</td> </tr> <tr> <td colspan="5">System setting</td> </tr> <tr> <td colspan="5" style="text-align: center; border-top: 1px dashed black;"> Return Homepage Select </td> </tr> </table> | 16:02:35 | Fwd | Local | Ready | GD28 | Grouping parameters | | | | | User defined parameter setting | | | | | State monitoring | | | | | Motor parameter autotuning | | | | | Parameter backup/Restore default | | | | | System setting | | | | | Return Homepage Select | | | | | | | | | | | | | | |
| 16:02:35 | Fwd | Local | Ready | GD28 | | | | | | | | | | | | | | | | | | | | | | | | | | | | | | | | | | | | | | | | | | | | | | | | | | | | | | | | | | | | | | | | | | | | | | | | |
| Set Freq | P17.00 | Hz | 50.00 | | | | | | | | | | | | | | | | | | | | | | | | | | | | | | | | | | | | | | | | | | | | | | | | | | | | | | | | | | | | | | | | | | | | | | | | | |
| DC BusVolt | P17.11 | V | 540.0 | | | | | | | | | | | | | | | | | | | | | | | | | | | | | | | | | | | | | | | | | | | | | | | | | | | | | | | | | | | | | | | | | | | | | | | | | |
| DigInpTrmlState | P17.12 | | 000000 | | | | | | | | | | | | | | | | | | | | | | | | | | | | | | | | | | | | | | | | | | | | | | | | | | | | | | | | | | | | | | | | | | | | | | | | | |
| Parameters About Menu | | | | | | | | | | | | | | | | | | | | | | | | | | | | | | | | | | | | | | | | | | | | | | | | | | | | | | | | | | | | | | | | | | | | | | | | | | | | |
| 16:02:35 | Fwd | Local | Ready | GD28 | | | | | | | | | | | | | | | | | | | | | | | | | | | | | | | | | | | | | | | | | | | | | | | | | | | | | | | | | | | | | | | | | | | | | | | | |
| Grouping parameters | | | | | | | | | | | | | | | | | | | | | | | | | | | | | | | | | | | | | | | | | | | | | | | | | | | | | | | | | | | | | | | | | | | | | | | | | | | | |
| User defined parameter setting | | | | | | | | | | | | | | | | | | | | | | | | | | | | | | | | | | | | | | | | | | | | | | | | | | | | | | | | | | | | | | | | | | | | | | | | | | | | |
| State monitoring | | | | | | | | | | | | | | | | | | | | | | | | | | | | | | | | | | | | | | | | | | | | | | | | | | | | | | | | | | | | | | | | | | | | | | | | | | | | |
| Motor parameter autotuning | | | | | | | | | | | | | | | | | | | | | | | | | | | | | | | | | | | | | | | | | | | | | | | | | | | | | | | | | | | | | | | | | | | | | | | | | | | | |
| Parameter backup/Restore default | | | | | | | | | | | | | | | | | | | | | | | | | | | | | | | | | | | | | | | | | | | | | | | | | | | | | | | | | | | | | | | | | | | | | | | | | | | | |
| System setting | | | | | | | | | | | | | | | | | | | | | | | | | | | | | | | | | | | | | | | | | | | | | | | | | | | | | | | | | | | | | | | | | | | | | | | | | | | | |
| Return Homepage Select | | | | | | | | | | | | | | | | | | | | | | | | | | | | | | | | | | | | | | | | | | | | | | | | | | | | | | | | | | | | | | | | | | | | | | | | | | | | |
| <p>Step 3 Press to select State parameter monitoring, and press to confirm.</p> <table border="1" style="width: 100%; border-collapse: collapse;"> <tr> <td style="font-size: small;">16:02:35</td> <td style="font-size: small;">Fwd</td> <td style="font-size: small;">Local</td> <td style="font-size: small;">Ready</td> <td style="font-size: small;">GD28</td> </tr> <tr> <td colspan="5" style="background-color: #e0e0e0;">State parameter monitoring</td> </tr> <tr> <td colspan="5">Fault type record</td> </tr> <tr> <td colspan="5">View fault parameter</td> </tr> <tr> <td colspan="5">Clear fault record</td> </tr> <tr> <td colspan="5">Modified parameter</td> </tr> <tr> <td colspan="5">User defined home parameters</td> </tr> <tr> <td colspan="5" style="text-align: center; border-top: 1px dashed black;"> Return Homepage Select </td> </tr> </table> | 16:02:35 | Fwd | Local | Ready | GD28 | State parameter monitoring | | | | | Fault type record | | | | | View fault parameter | | | | | Clear fault record | | | | | Modified parameter | | | | | User defined home parameters | | | | | Return Homepage Select | | | | | <p>Step 4 Press to select function code group P17, and press to confirm.</p> <table border="1" style="width: 100%; border-collapse: collapse;"> <tr> <td style="font-size: small;">16:02:35</td> <td style="font-size: small;">Fwd</td> <td style="font-size: small;">Local</td> <td style="font-size: small;">Ready</td> <td style="font-size: small;">GD28</td> </tr> <tr> <td colspan="5">P07: HMI</td> </tr> <tr> <td colspan="5" style="background-color: #e0e0e0;">P17: State Viewing Func</td> </tr> <tr> <td colspan="5">P18: Cl-IpCtrlStateView</td> </tr> <tr> <td colspan="5">P19: Ex-card StateView</td> </tr> <tr> <td colspan="5">P93: TensionCtrl StateViewing</td> </tr> <tr> <td colspan="5" style="text-align: center; border-top: 1px dashed black;"> Return Homepage Select </td> </tr> </table> | 16:02:35 | Fwd | Local | Ready | GD28 | P07: HMI | | | | | P17: State Viewing Func | | | | | P18: Cl-IpCtrlStateView | | | | | P19: Ex-card StateView | | | | | P93: TensionCtrl StateViewing | | | | | Return Homepage Select | | | | |
| 16:02:35 | Fwd | Local | Ready | GD28 | | | | | | | | | | | | | | | | | | | | | | | | | | | | | | | | | | | | | | | | | | | | | | | | | | | | | | | | | | | | | | | | | | | | | | | | |
| State parameter monitoring | | | | | | | | | | | | | | | | | | | | | | | | | | | | | | | | | | | | | | | | | | | | | | | | | | | | | | | | | | | | | | | | | | | | | | | | | | | | |
| Fault type record | | | | | | | | | | | | | | | | | | | | | | | | | | | | | | | | | | | | | | | | | | | | | | | | | | | | | | | | | | | | | | | | | | | | | | | | | | | | |
| View fault parameter | | | | | | | | | | | | | | | | | | | | | | | | | | | | | | | | | | | | | | | | | | | | | | | | | | | | | | | | | | | | | | | | | | | | | | | | | | | | |
| Clear fault record | | | | | | | | | | | | | | | | | | | | | | | | | | | | | | | | | | | | | | | | | | | | | | | | | | | | | | | | | | | | | | | | | | | | | | | | | | | | |
| Modified parameter | | | | | | | | | | | | | | | | | | | | | | | | | | | | | | | | | | | | | | | | | | | | | | | | | | | | | | | | | | | | | | | | | | | | | | | | | | | | |
| User defined home parameters | | | | | | | | | | | | | | | | | | | | | | | | | | | | | | | | | | | | | | | | | | | | | | | | | | | | | | | | | | | | | | | | | | | | | | | | | | | | |
| Return Homepage Select | | | | | | | | | | | | | | | | | | | | | | | | | | | | | | | | | | | | | | | | | | | | | | | | | | | | | | | | | | | | | | | | | | | | | | | | | | | | |
| 16:02:35 | Fwd | Local | Ready | GD28 | | | | | | | | | | | | | | | | | | | | | | | | | | | | | | | | | | | | | | | | | | | | | | | | | | | | | | | | | | | | | | | | | | | | | | | | |
| P07: HMI | | | | | | | | | | | | | | | | | | | | | | | | | | | | | | | | | | | | | | | | | | | | | | | | | | | | | | | | | | | | | | | | | | | | | | | | | | | | |
| P17: State Viewing Func | | | | | | | | | | | | | | | | | | | | | | | | | | | | | | | | | | | | | | | | | | | | | | | | | | | | | | | | | | | | | | | | | | | | | | | | | | | | |
| P18: Cl-IpCtrlStateView | | | | | | | | | | | | | | | | | | | | | | | | | | | | | | | | | | | | | | | | | | | | | | | | | | | | | | | | | | | | | | | | | | | | | | | | | | | | |
| P19: Ex-card StateView | | | | | | | | | | | | | | | | | | | | | | | | | | | | | | | | | | | | | | | | | | | | | | | | | | | | | | | | | | | | | | | | | | | | | | | | | | | | |
| P93: TensionCtrl StateViewing | | | | | | | | | | | | | | | | | | | | | | | | | | | | | | | | | | | | | | | | | | | | | | | | | | | | | | | | | | | | | | | | | | | | | | | | | | | | |
| Return Homepage Select | | | | | | | | | | | | | | | | | | | | | | | | | | | | | | | | | | | | | | | | | | | | | | | | | | | | | | | | | | | | | | | | | | | | | | | | | | | | |
| <p>Step 5 Press the key corresponding to Select.</p> <table border="1" style="width: 100%; border-collapse: collapse;"> <tr> <td style="font-size: small;">16:02:35</td> <td style="font-size: small;">Fwd</td> <td style="font-size: small;">Local</td> <td style="font-size: small;">Ready</td> <td style="font-size: small;">GD28</td> </tr> <tr> <td colspan="5" style="background-color: #e0e0e0;">P17.00: Set Freq</td> </tr> <tr> <td colspan="5">P17.01: Output Freq</td> </tr> <tr> <td colspan="5">P17.02: Ramp RefFreq</td> </tr> <tr> <td colspan="5">P17.03: OutpVolt</td> </tr> <tr> <td colspan="5">P17.04: OutpCur</td> </tr> <tr> <td colspan="5">P17.05: Motor Speed</td> </tr> <tr> <td colspan="5" style="text-align: center; border-top: 1px dashed black;"> Return Add Select </td> </tr> </table> | 16:02:35 | Fwd | Local | Ready | GD28 | P17.00: Set Freq | | | | | P17.01: Output Freq | | | | | P17.02: Ramp RefFreq | | | | | P17.03: OutpVolt | | | | | P17.04: OutpCur | | | | | P17.05: Motor Speed | | | | | Return Add Select | | | | | <p>Step 6 Press the key corresponding to Confirm to display the next function code, or press the key corresponding to Return to return to the current function code group.</p> <table border="1" style="width: 100%; border-collapse: collapse;"> <tr> <td style="font-size: small;">16:02:35</td> <td style="font-size: small;">Fwd</td> <td style="font-size: small;">Local</td> <td style="font-size: small;">Ready</td> <td style="font-size: small;">GD28</td> </tr> <tr> <td colspan="2">Max. OutputFreq</td> <td></td> <td>50.00</td> <td>Hz</td> </tr> <tr> <td colspan="5">Max: 50.00</td> </tr> <tr> <td colspan="5">Min: 0.0</td> </tr> <tr> <td colspan="5">Default: 0.0</td> </tr> <tr> <td colspan="5" style="text-align: center; border-top: 1px dashed black;"> Return Homepage Confirm </td> </tr> </table> | 16:02:35 | Fwd | Local | Ready | GD28 | Max. OutputFreq | | | 50.00 | Hz | Max: 50.00 | | | | | Min: 0.0 | | | | | Default: 0.0 | | | | | Return Homepage Confirm | | | | | | | | | |
| 16:02:35 | Fwd | Local | Ready | GD28 | | | | | | | | | | | | | | | | | | | | | | | | | | | | | | | | | | | | | | | | | | | | | | | | | | | | | | | | | | | | | | | | | | | | | | | | |
| P17.00: Set Freq | | | | | | | | | | | | | | | | | | | | | | | | | | | | | | | | | | | | | | | | | | | | | | | | | | | | | | | | | | | | | | | | | | | | | | | | | | | | |
| P17.01: Output Freq | | | | | | | | | | | | | | | | | | | | | | | | | | | | | | | | | | | | | | | | | | | | | | | | | | | | | | | | | | | | | | | | | | | | | | | | | | | | |
| P17.02: Ramp RefFreq | | | | | | | | | | | | | | | | | | | | | | | | | | | | | | | | | | | | | | | | | | | | | | | | | | | | | | | | | | | | | | | | | | | | | | | | | | | | |
| P17.03: OutpVolt | | | | | | | | | | | | | | | | | | | | | | | | | | | | | | | | | | | | | | | | | | | | | | | | | | | | | | | | | | | | | | | | | | | | | | | | | | | | |
| P17.04: OutpCur | | | | | | | | | | | | | | | | | | | | | | | | | | | | | | | | | | | | | | | | | | | | | | | | | | | | | | | | | | | | | | | | | | | | | | | | | | | | |
| P17.05: Motor Speed | | | | | | | | | | | | | | | | | | | | | | | | | | | | | | | | | | | | | | | | | | | | | | | | | | | | | | | | | | | | | | | | | | | | | | | | | | | | |
| Return Add Select | | | | | | | | | | | | | | | | | | | | | | | | | | | | | | | | | | | | | | | | | | | | | | | | | | | | | | | | | | | | | | | | | | | | | | | | | | | | |
| 16:02:35 | Fwd | Local | Ready | GD28 | | | | | | | | | | | | | | | | | | | | | | | | | | | | | | | | | | | | | | | | | | | | | | | | | | | | | | | | | | | | | | | | | | | | | | | | |
| Max. OutputFreq | | | 50.00 | Hz | | | | | | | | | | | | | | | | | | | | | | | | | | | | | | | | | | | | | | | | | | | | | | | | | | | | | | | | | | | | | | | | | | | | | | | | |
| Max: 50.00 | | | | | | | | | | | | | | | | | | | | | | | | | | | | | | | | | | | | | | | | | | | | | | | | | | | | | | | | | | | | | | | | | | | | | | | | | | | | |
| Min: 0.0 | | | | | | | | | | | | | | | | | | | | | | | | | | | | | | | | | | | | | | | | | | | | | | | | | | | | | | | | | | | | | | | | | | | | | | | | | | | | |
| Default: 0.0 | | | | | | | | | | | | | | | | | | | | | | | | | | | | | | | | | | | | | | | | | | | | | | | | | | | | | | | | | | | | | | | | | | | | | | | | | | | | |
| Return Homepage Confirm | | | | | | | | | | | | | | | | | | | | | | | | | | | | | | | | | | | | | | | | | | | | | | | | | | | | | | | | | | | | | | | | | | | | | | | | | | | | |

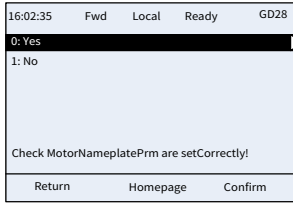
5.4.3.6 Motor parameter autotuning

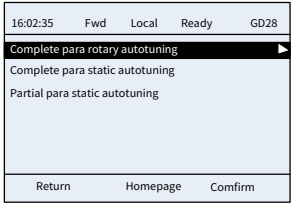
The operation example is as follows:

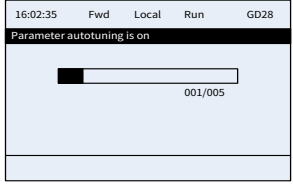

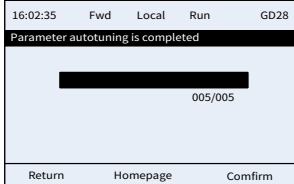
| | |
|---|--|
| <p>Step 1 In the stopped state homepage, press the key corresponding to Menu to select the menu item.</p> | <p>Step 2 Press to select Motor parameter autotuning, and press to confirm.</p> |
|---|--|

| | |
|--|---|
|  |  |
| <p>Step 3 (Assume that the motor nameplate parameters have been set.) Press the key  corresponding to Confirm.</p>  | <p>Step 4 Press  to select Complete para rotary autotuning.</p>  |
| <p>Step 5 The page shows the autotuning progress, and you can press the key  corresponding to Stop to end the autotuning.</p>  | <p>Step 6 Press the key  corresponding to Confirm.</p>  |

5.4.3.7 Backing up parameters

The keypad provides three different storage areas for parameter backup, and each storage area can save the parameters of one VFD, namely it can save parameters of three VFDs in total.

The operation example is as follows:

| | |
|--|--|
| <p>Step 1 In the stopped state homepage, press the key  corresponding to Menu to select the menu item.</p> | <p>Step 2 Press  to select Parameter backup/Restore default, and press  to confirm.</p> |
|--|--|

| | | | | | | | | | | | | | | | | | | | | | | | | | | | | | | | | | | | | | | | | | | | | | | | | | | | | | | | | | | | | | | | | | | | | | | | | | | | | | | | | | | | | | | | | | | | | | | | | | | | | | |
|---|----------|----------|--------|-------|------|----------------------|-----------------------------------|--|-------|--|----------------------|---|--|--|--|----------------------|--|--|--|--|--------------------------------------|--------|----------|---------|--|-------------------------------|---|--|--|--|---------------------------------------|--|--|--|--|----------------|--|--|--------|--|--------|------|--------|--|--|---|----------|-----|-------|-------|------------|----------------------------|------|--|--|---|--------------------------------|-----|-------|-------|------|-------------------------------------|--|--|--|--|-----------------------------------|--|--|--|--|------------------|--|--|--|--|----------------------------|----------|---------|--|--|----------------------------------|--|--|--|--|----------------|--|--|--|--|--|--|--|--|--|--------|----------|--------|--|--|
| <table border="1" style="width: 100%; border-collapse: collapse;"> <tr> <td style="font-size: small;">16:02:35</td> <td style="font-size: small;">Fwd</td> <td style="font-size: small;">Local</td> <td style="font-size: small;">Ready</td> <td style="font-size: small;">GD28</td> </tr> <tr> <td>Set Freq</td> <td colspan="2"></td> <td>50.00</td> <td></td> </tr> <tr> <td>P17.00</td> <td>Hz</td> <td colspan="2"></td> <td></td> </tr> <tr> <td colspan="5" style="border-top: 1px dashed black;"></td> </tr> <tr> <td>DC BusVolt</td> <td colspan="2"></td> <td>540.0</td> <td></td> </tr> <tr> <td>P17.11</td> <td>V</td> <td colspan="2"></td> <td></td> </tr> <tr> <td colspan="5" style="border-top: 1px dashed black;"></td> </tr> <tr> <td>DigInPrmIState</td> <td colspan="2"></td> <td>000000</td> <td></td> </tr> <tr> <td>P17.12</td> <td colspan="4"></td> </tr> <tr> <td colspan="5" style="border-top: 1px dashed black;"></td> </tr> <tr> <td style="text-align: center;">Parameters</td> <td style="text-align: center;">About</td> <td colspan="3" style="text-align: center;">Menu</td> </tr> </table> | 16:02:35 | Fwd | Local | Ready | GD28 | Set Freq | | | 50.00 | | P17.00 | Hz | | | | | | | | | DC BusVolt | | | 540.0 | | P17.11 | V | | | | | | | | | DigInPrmIState | | | 000000 | | P17.12 | | | | | | | | | | Parameters | About | Menu | | | <table border="1" style="width: 100%; border-collapse: collapse;"> <tr> <td style="font-size: small;">16:02:35</td> <td style="font-size: small;">Fwd</td> <td style="font-size: small;">Local</td> <td style="font-size: small;">Ready</td> <td style="font-size: small;">GD28</td> </tr> <tr> <td colspan="5">Grouping parameters</td> </tr> <tr> <td colspan="5">User defined parameter setting</td> </tr> <tr> <td colspan="5">State monitoring</td> </tr> <tr> <td colspan="5">Motor parameter autotuning</td> </tr> <tr> <td colspan="5" style="border-top: 2px solid black;">Parameter backup/Restore default</td> </tr> <tr> <td colspan="5">System setting</td> </tr> <tr> <td colspan="5" style="border-top: 1px dashed black;"></td> </tr> <tr> <td style="text-align: center;">Return</td> <td style="text-align: center;">Homepage</td> <td colspan="3" style="text-align: center;">Select</td> </tr> </table> | 16:02:35 | Fwd | Local | Ready | GD28 | Grouping parameters | | | | | User defined parameter setting | | | | | State monitoring | | | | | Motor parameter autotuning | | | | | Parameter backup/Restore default | | | | | System setting | | | | | | | | | | Return | Homepage | Select | | |
| 16:02:35 | Fwd | Local | Ready | GD28 | | | | | | | | | | | | | | | | | | | | | | | | | | | | | | | | | | | | | | | | | | | | | | | | | | | | | | | | | | | | | | | | | | | | | | | | | | | | | | | | | | | | | | | | | | | | | | | | | |
| Set Freq | | | 50.00 | | | | | | | | | | | | | | | | | | | | | | | | | | | | | | | | | | | | | | | | | | | | | | | | | | | | | | | | | | | | | | | | | | | | | | | | | | | | | | | | | | | | | | | | | | | | | | | | | | |
| P17.00 | Hz | | | | | | | | | | | | | | | | | | | | | | | | | | | | | | | | | | | | | | | | | | | | | | | | | | | | | | | | | | | | | | | | | | | | | | | | | | | | | | | | | | | | | | | | | | | | | | | | | | | | |
| | | | | | | | | | | | | | | | | | | | | | | | | | | | | | | | | | | | | | | | | | | | | | | | | | | | | | | | | | | | | | | | | | | | | | | | | | | | | | | | | | | | | | | | | | | | | | | | | | | | | | |
| DC BusVolt | | | 540.0 | | | | | | | | | | | | | | | | | | | | | | | | | | | | | | | | | | | | | | | | | | | | | | | | | | | | | | | | | | | | | | | | | | | | | | | | | | | | | | | | | | | | | | | | | | | | | | | | | | |
| P17.11 | V | | | | | | | | | | | | | | | | | | | | | | | | | | | | | | | | | | | | | | | | | | | | | | | | | | | | | | | | | | | | | | | | | | | | | | | | | | | | | | | | | | | | | | | | | | | | | | | | | | | | |
| | | | | | | | | | | | | | | | | | | | | | | | | | | | | | | | | | | | | | | | | | | | | | | | | | | | | | | | | | | | | | | | | | | | | | | | | | | | | | | | | | | | | | | | | | | | | | | | | | | | | | |
| DigInPrmIState | | | 000000 | | | | | | | | | | | | | | | | | | | | | | | | | | | | | | | | | | | | | | | | | | | | | | | | | | | | | | | | | | | | | | | | | | | | | | | | | | | | | | | | | | | | | | | | | | | | | | | | | | |
| P17.12 | | | | | | | | | | | | | | | | | | | | | | | | | | | | | | | | | | | | | | | | | | | | | | | | | | | | | | | | | | | | | | | | | | | | | | | | | | | | | | | | | | | | | | | | | | | | | | | | | | | | | |
| | | | | | | | | | | | | | | | | | | | | | | | | | | | | | | | | | | | | | | | | | | | | | | | | | | | | | | | | | | | | | | | | | | | | | | | | | | | | | | | | | | | | | | | | | | | | | | | | | | | | | |
| Parameters | About | Menu | | | | | | | | | | | | | | | | | | | | | | | | | | | | | | | | | | | | | | | | | | | | | | | | | | | | | | | | | | | | | | | | | | | | | | | | | | | | | | | | | | | | | | | | | | | | | | | | | | | |
| 16:02:35 | Fwd | Local | Ready | GD28 | | | | | | | | | | | | | | | | | | | | | | | | | | | | | | | | | | | | | | | | | | | | | | | | | | | | | | | | | | | | | | | | | | | | | | | | | | | | | | | | | | | | | | | | | | | | | | | | | |
| Grouping parameters | | | | | | | | | | | | | | | | | | | | | | | | | | | | | | | | | | | | | | | | | | | | | | | | | | | | | | | | | | | | | | | | | | | | | | | | | | | | | | | | | | | | | | | | | | | | | | | | | | | | | |
| User defined parameter setting | | | | | | | | | | | | | | | | | | | | | | | | | | | | | | | | | | | | | | | | | | | | | | | | | | | | | | | | | | | | | | | | | | | | | | | | | | | | | | | | | | | | | | | | | | | | | | | | | | | | | |
| State monitoring | | | | | | | | | | | | | | | | | | | | | | | | | | | | | | | | | | | | | | | | | | | | | | | | | | | | | | | | | | | | | | | | | | | | | | | | | | | | | | | | | | | | | | | | | | | | | | | | | | | | | |
| Motor parameter autotuning | | | | | | | | | | | | | | | | | | | | | | | | | | | | | | | | | | | | | | | | | | | | | | | | | | | | | | | | | | | | | | | | | | | | | | | | | | | | | | | | | | | | | | | | | | | | | | | | | | | | | |
| Parameter backup/Restore default | | | | | | | | | | | | | | | | | | | | | | | | | | | | | | | | | | | | | | | | | | | | | | | | | | | | | | | | | | | | | | | | | | | | | | | | | | | | | | | | | | | | | | | | | | | | | | | | | | | | | |
| System setting | | | | | | | | | | | | | | | | | | | | | | | | | | | | | | | | | | | | | | | | | | | | | | | | | | | | | | | | | | | | | | | | | | | | | | | | | | | | | | | | | | | | | | | | | | | | | | | | | | | | | |
| | | | | | | | | | | | | | | | | | | | | | | | | | | | | | | | | | | | | | | | | | | | | | | | | | | | | | | | | | | | | | | | | | | | | | | | | | | | | | | | | | | | | | | | | | | | | | | | | | | | | | |
| Return | Homepage | Select | | | | | | | | | | | | | | | | | | | | | | | | | | | | | | | | | | | | | | | | | | | | | | | | | | | | | | | | | | | | | | | | | | | | | | | | | | | | | | | | | | | | | | | | | | | | | | | | | | | |
| <p>Step 3 Press to select MemoryArea1: BACKUP01.</p> <table border="1" style="width: 100%; border-collapse: collapse;"> <tr> <td style="font-size: small;">16:02:35</td> <td style="font-size: small;">Fwd</td> <td style="font-size: small;">Local</td> <td style="font-size: small;">Ready</td> <td style="font-size: small;">GD28</td> </tr> <tr> <td colspan="5" style="border-top: 2px solid black;">MemoryArea1:BACKUP01</td> </tr> <tr> <td colspan="5">MemoryArea2:BACKUP02</td> </tr> <tr> <td colspan="5">MemoryArea3:BACKUP03</td> </tr> <tr> <td colspan="5">Restore to default(except motor prm)</td> </tr> <tr> <td colspan="5">Restore to default(test mode)</td> </tr> <tr> <td colspan="5">Restore to default(include motor prm)</td> </tr> <tr> <td colspan="5" style="border-top: 1px dashed black;"></td> </tr> <tr> <td style="text-align: center;">Return</td> <td style="text-align: center;">Edit</td> <td colspan="3" style="text-align: center;">Select</td> </tr> </table> | 16:02:35 | Fwd | Local | Ready | GD28 | MemoryArea1:BACKUP01 | | | | | MemoryArea2:BACKUP02 | | | | | MemoryArea3:BACKUP03 | | | | | Restore to default(except motor prm) | | | | | Restore to default(test mode) | | | | | Restore to default(include motor prm) | | | | | | | | | | Return | Edit | Select | | | <p>Step 4 Press to select UL local FuncPrm to keypad.</p> <table border="1" style="width: 100%; border-collapse: collapse;"> <tr> <td style="font-size: small;">16:02:35</td> <td style="font-size: small;">Fwd</td> <td style="font-size: small;">Local</td> <td style="font-size: small;">Ready</td> <td style="font-size: small;">GD28</td> </tr> <tr> <td colspan="5" style="border-top: 2px solid black;">UL local FuncPrm to keypad</td> </tr> <tr> <td colspan="5">DL complete func prm of keypad</td> </tr> <tr> <td colspan="5">DL Non-motor GroupFuncPrm of keypad</td> </tr> <tr> <td colspan="5">DL motor group func prm of keypad</td> </tr> <tr> <td colspan="5" style="border-top: 1px dashed black;"></td> </tr> <tr> <td style="text-align: center;">Return</td> <td style="text-align: center;">Homepage</td> <td colspan="3" style="text-align: center;">Confirm</td> </tr> </table> | 16:02:35 | Fwd | Local | Ready | GD28 | UL local FuncPrm to keypad | | | | | DL complete func prm of keypad | | | | | DL Non-motor GroupFuncPrm of keypad | | | | | DL motor group func prm of keypad | | | | | | | | | | Return | Homepage | Confirm | | | | | | | | | | | | | | | | | | | | | | |
| 16:02:35 | Fwd | Local | Ready | GD28 | | | | | | | | | | | | | | | | | | | | | | | | | | | | | | | | | | | | | | | | | | | | | | | | | | | | | | | | | | | | | | | | | | | | | | | | | | | | | | | | | | | | | | | | | | | | | | | | | |
| MemoryArea1:BACKUP01 | | | | | | | | | | | | | | | | | | | | | | | | | | | | | | | | | | | | | | | | | | | | | | | | | | | | | | | | | | | | | | | | | | | | | | | | | | | | | | | | | | | | | | | | | | | | | | | | | | | | | |
| MemoryArea2:BACKUP02 | | | | | | | | | | | | | | | | | | | | | | | | | | | | | | | | | | | | | | | | | | | | | | | | | | | | | | | | | | | | | | | | | | | | | | | | | | | | | | | | | | | | | | | | | | | | | | | | | | | | | |
| MemoryArea3:BACKUP03 | | | | | | | | | | | | | | | | | | | | | | | | | | | | | | | | | | | | | | | | | | | | | | | | | | | | | | | | | | | | | | | | | | | | | | | | | | | | | | | | | | | | | | | | | | | | | | | | | | | | | |
| Restore to default(except motor prm) | | | | | | | | | | | | | | | | | | | | | | | | | | | | | | | | | | | | | | | | | | | | | | | | | | | | | | | | | | | | | | | | | | | | | | | | | | | | | | | | | | | | | | | | | | | | | | | | | | | | | |
| Restore to default(test mode) | | | | | | | | | | | | | | | | | | | | | | | | | | | | | | | | | | | | | | | | | | | | | | | | | | | | | | | | | | | | | | | | | | | | | | | | | | | | | | | | | | | | | | | | | | | | | | | | | | | | | |
| Restore to default(include motor prm) | | | | | | | | | | | | | | | | | | | | | | | | | | | | | | | | | | | | | | | | | | | | | | | | | | | | | | | | | | | | | | | | | | | | | | | | | | | | | | | | | | | | | | | | | | | | | | | | | | | | | |
| | | | | | | | | | | | | | | | | | | | | | | | | | | | | | | | | | | | | | | | | | | | | | | | | | | | | | | | | | | | | | | | | | | | | | | | | | | | | | | | | | | | | | | | | | | | | | | | | | | | | | |
| Return | Edit | Select | | | | | | | | | | | | | | | | | | | | | | | | | | | | | | | | | | | | | | | | | | | | | | | | | | | | | | | | | | | | | | | | | | | | | | | | | | | | | | | | | | | | | | | | | | | | | | | | | | | |
| 16:02:35 | Fwd | Local | Ready | GD28 | | | | | | | | | | | | | | | | | | | | | | | | | | | | | | | | | | | | | | | | | | | | | | | | | | | | | | | | | | | | | | | | | | | | | | | | | | | | | | | | | | | | | | | | | | | | | | | | | |
| UL local FuncPrm to keypad | | | | | | | | | | | | | | | | | | | | | | | | | | | | | | | | | | | | | | | | | | | | | | | | | | | | | | | | | | | | | | | | | | | | | | | | | | | | | | | | | | | | | | | | | | | | | | | | | | | | | |
| DL complete func prm of keypad | | | | | | | | | | | | | | | | | | | | | | | | | | | | | | | | | | | | | | | | | | | | | | | | | | | | | | | | | | | | | | | | | | | | | | | | | | | | | | | | | | | | | | | | | | | | | | | | | | | | | |
| DL Non-motor GroupFuncPrm of keypad | | | | | | | | | | | | | | | | | | | | | | | | | | | | | | | | | | | | | | | | | | | | | | | | | | | | | | | | | | | | | | | | | | | | | | | | | | | | | | | | | | | | | | | | | | | | | | | | | | | | | |
| DL motor group func prm of keypad | | | | | | | | | | | | | | | | | | | | | | | | | | | | | | | | | | | | | | | | | | | | | | | | | | | | | | | | | | | | | | | | | | | | | | | | | | | | | | | | | | | | | | | | | | | | | | | | | | | | | |
| | | | | | | | | | | | | | | | | | | | | | | | | | | | | | | | | | | | | | | | | | | | | | | | | | | | | | | | | | | | | | | | | | | | | | | | | | | | | | | | | | | | | | | | | | | | | | | | | | | | | | |
| Return | Homepage | Confirm | | | | | | | | | | | | | | | | | | | | | | | | | | | | | | | | | | | | | | | | | | | | | | | | | | | | | | | | | | | | | | | | | | | | | | | | | | | | | | | | | | | | | | | | | | | | | | | | | | | |
| <p>Step 5 After parameter uploading is completed, press Confirm or Return to return to the previous menu.</p> <table border="1" style="width: 100%; border-collapse: collapse;"> <tr> <td style="font-size: small;">16:02:35</td> <td style="font-size: small;">Fwd</td> <td style="font-size: small;">Local</td> <td style="font-size: small;">Run</td> <td style="font-size: small;">GD28</td> </tr> <tr> <td colspan="5" style="border-top: 2px solid black;">Prm in memory area 1 have been UL</td> </tr> <tr> <td colspan="5" style="height: 50px; text-align: center; vertical-align: middle;"> <div style="background-color: black; width: 100%; height: 15px; margin: 0 auto;"></div> </td> </tr> <tr> <td colspan="5" style="border-top: 1px dashed black;"></td> </tr> <tr> <td style="text-align: center;">Return</td> <td style="text-align: center;">Homepage</td> <td colspan="3" style="text-align: center;">Confirm</td> </tr> </table> | | 16:02:35 | Fwd | Local | Run | GD28 | Prm in memory area 1 have been UL | | | | | <div style="background-color: black; width: 100%; height: 15px; margin: 0 auto;"></div> | | | | | | | | | | Return | Homepage | Confirm | | | | | | | | | | | | | | | | | | | | | | | | | | | | | | | | | | | | | | | | | | | | | | | | | | | | | | | | | | | | | | | | | | | | | | | | | | | | | |
| 16:02:35 | Fwd | Local | Run | GD28 | | | | | | | | | | | | | | | | | | | | | | | | | | | | | | | | | | | | | | | | | | | | | | | | | | | | | | | | | | | | | | | | | | | | | | | | | | | | | | | | | | | | | | | | | | | | | | | | | |
| Prm in memory area 1 have been UL | | | | | | | | | | | | | | | | | | | | | | | | | | | | | | | | | | | | | | | | | | | | | | | | | | | | | | | | | | | | | | | | | | | | | | | | | | | | | | | | | | | | | | | | | | | | | | | | | | | | | |
| <div style="background-color: black; width: 100%; height: 15px; margin: 0 auto;"></div> | | | | | | | | | | | | | | | | | | | | | | | | | | | | | | | | | | | | | | | | | | | | | | | | | | | | | | | | | | | | | | | | | | | | | | | | | | | | | | | | | | | | | | | | | | | | | | | | | | | | | |
| | | | | | | | | | | | | | | | | | | | | | | | | | | | | | | | | | | | | | | | | | | | | | | | | | | | | | | | | | | | | | | | | | | | | | | | | | | | | | | | | | | | | | | | | | | | | | | | | | | | | | |
| Return | Homepage | Confirm | | | | | | | | | | | | | | | | | | | | | | | | | | | | | | | | | | | | | | | | | | | | | | | | | | | | | | | | | | | | | | | | | | | | | | | | | | | | | | | | | | | | | | | | | | | | | | | | | | | |

5.4.3.8 System setup

You can set keypad language, time/date, backlight brightness, backlight time and restore parameters.

Note: The keypad time/date needs to be reset after power off.

The operation example is as follows:

| | |
|---|---|
| <p>Step 1 In the stopped state homepage, press the key corresponding to Menu to select the menu item.</p> | <p>Step 2 Press to select Language.</p> |
|---|---|

| | | | | | | | | | | | | | | | | | | | | | | | | | | | | | | | | | | | | | | | | | | | | | | | | | | | | | | | | | | | | | | | | | | | | | | | | | | | | | | | | | |
|--|------------|---------------------|---------|-----------------------|-------|----------|-------------------------------------|-------|--|------------------------------|-----------|--------|--|------------|------------|---|---------------|-------|--|--------------|----------|--|---|--|---------|--|----------|---------------------|-------|-------|--------|--------------------|-------|--|--|------------|------------------------------|-------|--|------|--|----------|-----|-------|-------|------|----------|--|--|--|--|-----------|--|--|--|--|----------------------|--|--|--|--|----------------|--|--|--|--|------------------------------|--|--|--|--|-----------------------|--|--|--|--|--------|--|----------|--|--------|
| <table border="1" style="width: 100%; border-collapse: collapse;"> <tr> <td style="font-size: small;">16:02:35</td> <td style="font-size: small;">Fwd</td> <td style="font-size: small;">Local</td> <td style="font-size: small;">Ready</td> <td style="font-size: small;">GD28</td> </tr> <tr> <td colspan="2">Set Freq</td> <td colspan="3" style="text-align: right;">50.00</td> </tr> <tr> <td colspan="2">P17.00 Hz</td> <td colspan="3">-----</td> </tr> <tr> <td colspan="2">DC BusVolt</td> <td colspan="3" style="text-align: right;">540.0</td> </tr> <tr> <td colspan="2">P17.11 V</td> <td colspan="3">-----</td> </tr> <tr> <td colspan="2">DigInPrmIState</td> <td colspan="3" style="text-align: right;">000000</td> </tr> <tr> <td colspan="2">P17.12</td> <td colspan="3">-----</td> </tr> <tr> <td colspan="2" style="text-align: center;">Parameters</td> <td colspan="2" style="text-align: center;">About</td> <td style="text-align: center;">Menu</td> </tr> </table> | 16:02:35 | Fwd | Local | Ready | GD28 | Set Freq | | 50.00 | | | P17.00 Hz | | ----- | | | DC BusVolt | | 540.0 | | | P17.11 V | | ----- | | | DigInPrmIState | | 000000 | | | P17.12 | | ----- | | | Parameters | | About | | Menu | <table border="1" style="width: 100%; border-collapse: collapse;"> <tr> <td style="font-size: small;">16:02:35</td> <td style="font-size: small;">Fwd</td> <td style="font-size: small;">Local</td> <td style="font-size: small;">Ready</td> <td style="font-size: small;">GD28</td> </tr> <tr> <td colspan="5">Language</td> </tr> <tr> <td colspan="5">Time/date</td> </tr> <tr> <td colspan="5">Backlight brightness</td> </tr> <tr> <td colspan="5">Backlight time</td> </tr> <tr> <td colspan="5">Enable power-on setup wizard</td> </tr> <tr> <td colspan="5">Power-on setup wizard</td> </tr> <tr> <td colspan="2" style="text-align: center;">Return</td> <td colspan="2" style="text-align: center;">Homepage</td> <td style="text-align: center;">Select</td> </tr> </table> | 16:02:35 | Fwd | Local | Ready | GD28 | Language | | | | | Time/date | | | | | Backlight brightness | | | | | Backlight time | | | | | Enable power-on setup wizard | | | | | Power-on setup wizard | | | | | Return | | Homepage | | Select |
| 16:02:35 | Fwd | Local | Ready | GD28 | | | | | | | | | | | | | | | | | | | | | | | | | | | | | | | | | | | | | | | | | | | | | | | | | | | | | | | | | | | | | | | | | | | | | | | | | | | | | |
| Set Freq | | 50.00 | | | | | | | | | | | | | | | | | | | | | | | | | | | | | | | | | | | | | | | | | | | | | | | | | | | | | | | | | | | | | | | | | | | | | | | | | | | | | | | |
| P17.00 Hz | | ----- | | | | | | | | | | | | | | | | | | | | | | | | | | | | | | | | | | | | | | | | | | | | | | | | | | | | | | | | | | | | | | | | | | | | | | | | | | | | | | | |
| DC BusVolt | | 540.0 | | | | | | | | | | | | | | | | | | | | | | | | | | | | | | | | | | | | | | | | | | | | | | | | | | | | | | | | | | | | | | | | | | | | | | | | | | | | | | | |
| P17.11 V | | ----- | | | | | | | | | | | | | | | | | | | | | | | | | | | | | | | | | | | | | | | | | | | | | | | | | | | | | | | | | | | | | | | | | | | | | | | | | | | | | | | |
| DigInPrmIState | | 000000 | | | | | | | | | | | | | | | | | | | | | | | | | | | | | | | | | | | | | | | | | | | | | | | | | | | | | | | | | | | | | | | | | | | | | | | | | | | | | | | |
| P17.12 | | ----- | | | | | | | | | | | | | | | | | | | | | | | | | | | | | | | | | | | | | | | | | | | | | | | | | | | | | | | | | | | | | | | | | | | | | | | | | | | | | | | |
| Parameters | | About | | Menu | | | | | | | | | | | | | | | | | | | | | | | | | | | | | | | | | | | | | | | | | | | | | | | | | | | | | | | | | | | | | | | | | | | | | | | | | | | | | |
| 16:02:35 | Fwd | Local | Ready | GD28 | | | | | | | | | | | | | | | | | | | | | | | | | | | | | | | | | | | | | | | | | | | | | | | | | | | | | | | | | | | | | | | | | | | | | | | | | | | | | |
| Language | | | | | | | | | | | | | | | | | | | | | | | | | | | | | | | | | | | | | | | | | | | | | | | | | | | | | | | | | | | | | | | | | | | | | | | | | | | | | | | | | |
| Time/date | | | | | | | | | | | | | | | | | | | | | | | | | | | | | | | | | | | | | | | | | | | | | | | | | | | | | | | | | | | | | | | | | | | | | | | | | | | | | | | | | |
| Backlight brightness | | | | | | | | | | | | | | | | | | | | | | | | | | | | | | | | | | | | | | | | | | | | | | | | | | | | | | | | | | | | | | | | | | | | | | | | | | | | | | | | | |
| Backlight time | | | | | | | | | | | | | | | | | | | | | | | | | | | | | | | | | | | | | | | | | | | | | | | | | | | | | | | | | | | | | | | | | | | | | | | | | | | | | | | | | |
| Enable power-on setup wizard | | | | | | | | | | | | | | | | | | | | | | | | | | | | | | | | | | | | | | | | | | | | | | | | | | | | | | | | | | | | | | | | | | | | | | | | | | | | | | | | | |
| Power-on setup wizard | | | | | | | | | | | | | | | | | | | | | | | | | | | | | | | | | | | | | | | | | | | | | | | | | | | | | | | | | | | | | | | | | | | | | | | | | | | | | | | | | |
| Return | | Homepage | | Select | | | | | | | | | | | | | | | | | | | | | | | | | | | | | | | | | | | | | | | | | | | | | | | | | | | | | | | | | | | | | | | | | | | | | | | | | | | | | |
| <p>Step 3 Press to select 1: English.</p> <table border="1" style="width: 100%; border-collapse: collapse;"> <tr> <td style="font-size: small;">Present: 0</td> <td style="font-size: small;">Default: 0</td> <td style="font-size: small;">Auth: ✓</td> </tr> <tr> <td colspan="3">0: Simplified Chinese</td> </tr> <tr> <td colspan="3">1: English</td> </tr> <tr> <td colspan="3" style="text-align: center;">Return Homepage Select</td> </tr> </table> | Present: 0 | Default: 0 | Auth: ✓ | 0: Simplified Chinese | | | 1: English | | | Return Homepage Select | | | <p>Step 4 Press to select 1: Just once, and press the key corresponding to Confirm.</p> <table border="1" style="width: 100%; border-collapse: collapse;"> <tr> <td style="font-size: small;">Present: 0</td> <td style="font-size: small;">Default: 0</td> <td style="font-size: small;">Auth: ✓</td> </tr> <tr> <td colspan="3">0: Every time</td> </tr> <tr> <td colspan="3">1: Just once</td> </tr> <tr> <td colspan="3" style="font-size: x-small;">Every time: Enable each time power up Just once: Prohibited next time Next, check whether to enter power-on guiding settings.</td> </tr> <tr> <td colspan="2" style="text-align: center;">Return</td> <td style="text-align: center;">Homepage Confirm</td> </tr> </table> | Present: 0 | Default: 0 | Auth: ✓ | 0: Every time | | | 1: Just once | | | Every time: Enable each time power up Just once: Prohibited next time Next, check whether to enter power-on guiding settings. | | | Return | | Homepage Confirm | | | | | | | | | | | | | | | | | | | | | | | | | | | | | | | | | | | | | | | | | | | | | | | | | | | | | |
| Present: 0 | Default: 0 | Auth: ✓ | | | | | | | | | | | | | | | | | | | | | | | | | | | | | | | | | | | | | | | | | | | | | | | | | | | | | | | | | | | | | | | | | | | | | | | | | | | | | | | |
| 0: Simplified Chinese | | | | | | | | | | | | | | | | | | | | | | | | | | | | | | | | | | | | | | | | | | | | | | | | | | | | | | | | | | | | | | | | | | | | | | | | | | | | | | | | | |
| 1: English | | | | | | | | | | | | | | | | | | | | | | | | | | | | | | | | | | | | | | | | | | | | | | | | | | | | | | | | | | | | | | | | | | | | | | | | | | | | | | | | | |
| Return Homepage Select | | | | | | | | | | | | | | | | | | | | | | | | | | | | | | | | | | | | | | | | | | | | | | | | | | | | | | | | | | | | | | | | | | | | | | | | | | | | | | | | | |
| Present: 0 | Default: 0 | Auth: ✓ | | | | | | | | | | | | | | | | | | | | | | | | | | | | | | | | | | | | | | | | | | | | | | | | | | | | | | | | | | | | | | | | | | | | | | | | | | | | | | | |
| 0: Every time | | | | | | | | | | | | | | | | | | | | | | | | | | | | | | | | | | | | | | | | | | | | | | | | | | | | | | | | | | | | | | | | | | | | | | | | | | | | | | | | | |
| 1: Just once | | | | | | | | | | | | | | | | | | | | | | | | | | | | | | | | | | | | | | | | | | | | | | | | | | | | | | | | | | | | | | | | | | | | | | | | | | | | | | | | | |
| Every time: Enable each time power up Just once: Prohibited next time Next, check whether to enter power-on guiding settings. | | | | | | | | | | | | | | | | | | | | | | | | | | | | | | | | | | | | | | | | | | | | | | | | | | | | | | | | | | | | | | | | | | | | | | | | | | | | | | | | | |
| Return | | Homepage Confirm | | | | | | | | | | | | | | | | | | | | | | | | | | | | | | | | | | | | | | | | | | | | | | | | | | | | | | | | | | | | | | | | | | | | | | | | | | | | | | | |
| <p>Step 5 Select the option corresponding to Yes and press the key to confirm.</p> <table border="1" style="width: 100%; border-collapse: collapse;"> <tr> <td style="font-size: small;">16:02:35</td> <td style="font-size: small;">Fwd</td> <td style="font-size: small;">Local</td> <td style="font-size: small;">Ready</td> <td style="font-size: small;">GD28</td> </tr> <tr> <td colspan="5">0: Yes</td> </tr> <tr> <td colspan="5">1: No</td> </tr> <tr> <td colspan="5" style="text-align: center;">Whether to enter the power-on guiding settings?</td> </tr> <tr> <td colspan="2" style="text-align: center;">Return</td> <td colspan="2" style="text-align: center;">Homepage</td> <td style="text-align: center;">Confirm</td> </tr> </table> | 16:02:35 | Fwd | Local | Ready | GD28 | 0: Yes | | | | | 1: No | | | | | Whether to enter the power-on guiding settings? | | | | | Return | | Homepage | | Confirm | <p>Step 6 Complete all parameter settings according to the on-screen instructions.</p> <table border="1" style="width: 100%; border-collapse: collapse;"> <tr> <td style="font-size: small;">16:02:35</td> <td style="font-size: small;">Fwd</td> <td style="font-size: small;">Local</td> <td style="font-size: small;">Ready</td> <td style="font-size: small;">GD28</td> </tr> <tr> <td colspan="5">P00.06: A Freq Cmd</td> </tr> <tr> <td colspan="5" style="text-align: center;">Return Homepage Select</td> </tr> </table> | 16:02:35 | Fwd | Local | Ready | GD28 | P00.06: A Freq Cmd | | | | | Return Homepage Select | | | | | | | | | | | | | | | | | | | | | | | | | | | | | | | | | | | | | | | | | | | | |
| 16:02:35 | Fwd | Local | Ready | GD28 | | | | | | | | | | | | | | | | | | | | | | | | | | | | | | | | | | | | | | | | | | | | | | | | | | | | | | | | | | | | | | | | | | | | | | | | | | | | | |
| 0: Yes | | | | | | | | | | | | | | | | | | | | | | | | | | | | | | | | | | | | | | | | | | | | | | | | | | | | | | | | | | | | | | | | | | | | | | | | | | | | | | | | | |
| 1: No | | | | | | | | | | | | | | | | | | | | | | | | | | | | | | | | | | | | | | | | | | | | | | | | | | | | | | | | | | | | | | | | | | | | | | | | | | | | | | | | | |
| Whether to enter the power-on guiding settings? | | | | | | | | | | | | | | | | | | | | | | | | | | | | | | | | | | | | | | | | | | | | | | | | | | | | | | | | | | | | | | | | | | | | | | | | | | | | | | | | | |
| Return | | Homepage | | Confirm | | | | | | | | | | | | | | | | | | | | | | | | | | | | | | | | | | | | | | | | | | | | | | | | | | | | | | | | | | | | | | | | | | | | | | | | | | | | | |
| 16:02:35 | Fwd | Local | Ready | GD28 | | | | | | | | | | | | | | | | | | | | | | | | | | | | | | | | | | | | | | | | | | | | | | | | | | | | | | | | | | | | | | | | | | | | | | | | | | | | | |
| P00.06: A Freq Cmd | | | | | | | | | | | | | | | | | | | | | | | | | | | | | | | | | | | | | | | | | | | | | | | | | | | | | | | | | | | | | | | | | | | | | | | | | | | | | | | | | |
| Return Homepage Select | | | | | | | | | | | | | | | | | | | | | | | | | | | | | | | | | | | | | | | | | | | | | | | | | | | | | | | | | | | | | | | | | | | | | | | | | | | | | | | | | |
| <p>Step 7 When finished, press the key corresponding to Confirm to go to the homepage.</p> <table border="1" style="width: 100%; border-collapse: collapse;"> <tr> <td style="font-size: small;">16:02:35</td> <td style="font-size: small;">Fwd</td> <td style="font-size: small;">Local</td> <td style="font-size: small;">Ready</td> <td style="font-size: small;">GD28</td> </tr> <tr> <td colspan="5" style="text-align: center;">Power-on guiding settings completed</td> </tr> <tr> <td colspan="2" style="text-align: center;">Return</td> <td colspan="2" style="text-align: center;">Homepage</td> <td style="text-align: center;">Confirm</td> </tr> </table> | | 16:02:35 | Fwd | Local | Ready | GD28 | Power-on guiding settings completed | | | | | Return | | Homepage | | Confirm | | | | | | | | | | | | | | | | | | | | | | | | | | | | | | | | | | | | | | | | | | | | | | | | | | | | | | | | | | | | | | | | | |
| 16:02:35 | Fwd | Local | Ready | GD28 | | | | | | | | | | | | | | | | | | | | | | | | | | | | | | | | | | | | | | | | | | | | | | | | | | | | | | | | | | | | | | | | | | | | | | | | | | | | | |
| Power-on guiding settings completed | | | | | | | | | | | | | | | | | | | | | | | | | | | | | | | | | | | | | | | | | | | | | | | | | | | | | | | | | | | | | | | | | | | | | | | | | | | | | | | | | |
| Return | | Homepage | | Confirm | | | | | | | | | | | | | | | | | | | | | | | | | | | | | | | | | | | | | | | | | | | | | | | | | | | | | | | | | | | | | | | | | | | | | | | | | | | | | |

6 Commissioning

The simplified VFD commissioning flowchart is as follows.

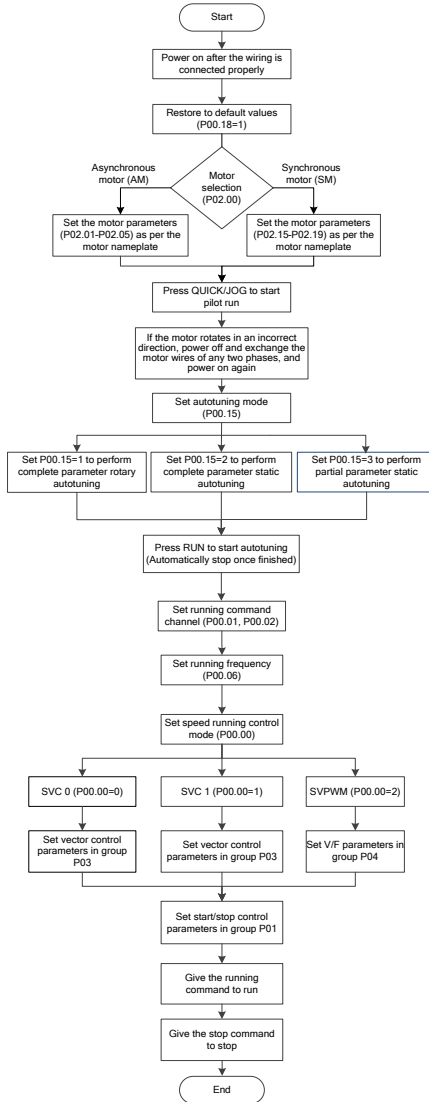

6.1 Motor parameter setting

The product supports the control of three-phase AC asynchronous motors and permanent magnet synchronous motors. The VFD supports the setting of two groups of motor parameters. Motor 1 corresponds to Group P02—Parameters of motor 1, and motor 2 corresponds to Group P34—Parameters of motor 2. Switching between the two sets of motor parameters can be achieved through multifunctional digital input terminals or communication methods.

6.1.1 Motor type selection

You can select the motor type by setting P02.00.

| Function code | Name | Default | Setting range | Description |
|---------------|-----------------|---------|---------------|---|
| P02.00 | Type of motor 1 | 0 | 0–1 | 0: Asynchronous motor (AM) 1: Permanent magnet synchronous motor |
| P34.00 | Type of motor 2 | 0 | 0–1 | 0: Asynchronous motor (AM) 1: Permanent magnet synchronous motor |

 **Note:** The types of motors that are driven at the same time must be the same.

6.1.2 Rated motor parameter setting

- **Set the rated parameters of three-phase AC asynchronous motors according to the motor nameplate.**

P02.01–P02.05 are used to set parameters of AM 1, and P34.01–P34.05 are used to set parameters of AM 2.

| Function code | Name | Default | Setting range | Description |
|---------------|-------------------------|----------------|---------------|---|
| P02.01 | Rated power of AM 1 | Model depended | 0.1–3000.0kW | - |
| P02.02 | Rated frequency of AM 1 | 50.00Hz | 0.01Hz–P00.03 | P00.03 specifies the max. output frequency. |
| P02.03 | Rated speed of AM 1 | Model depended | 1–60000Rpm | - |
| P02.04 | Rated voltage of AM 1 | Model depended | 0–1200V | - |
| P02.05 | Rated current of AM 1 | Model depended | 0.08–600.00A | - |

| Function code | Name | Default | Setting range | Description |
|---------------|-------------------------|----------------|---------------|---|
| P34.01 | Rated power of AM 2 | Model depended | 0.1–3000.0kW | - |
| P34.02 | Rated frequency of AM 2 | 50.00Hz | 0.01Hz–P00.03 | P00.03 specifies the max. output frequency. |
| P34.03 | Rated speed of AM 2 | Model depended | 1–60000Rpm | - |
| P34.04 | Rated voltage of AM 2 | Model depended | 0–1200V | - |
| P34.05 | Rated current of AM 2 | Model depended | 0.8–6000.0A | - |

- **Set the rated parameters of three-phase permanent magnetic synchronous motors according to the motor nameplate.**

P02.15–P02.19 are used to set parameters of SM 1, and P34.15–P34.19 are used to set parameters of SM 2.

| Function code | Name | Default | Setting range | Description |
|---------------|------------------------------|----------------|---------------|---|
| P02.15 | Rated power of SM 1 | Model depended | 0.1–3000.0kW | - |
| P02.16 | Rated frequency of SM 1 | 50.00Hz | 0.01Hz–P00.03 | P00.03 specifies the max. output frequency. |
| P02.17 | Number of pole pairs of SM 1 | 2 | 1–128 | - |
| P02.18 | Rated voltage of SM 1 | Model depended | 0–1200V | - |
| P02.19 | Rated current of SM 1 | Model depended | 0.08–600.00A | - |
| P34.15 | Rated power of SM 2 | Model depended | 0.1–3000.0kW | - |
| P34.16 | Rated frequency of SM 2 | 50.00Hz | 0.01Hz–P00.03 | P00.03 specifies the max. output frequency. |
| P34.17 | Number of pole pairs of SM 2 | 2 | 1–128 | - |
| P34.18 | Rated voltage of SM 2 | Model depended | 0–1200V | - |

| Function code | Name | Default | Setting range | Description |
|---------------|-----------------------|----------------|---------------|-------------|
| P34.19 | Rated current of SM 2 | Model depended | 0.8–6000.0A | - |

6.1.3 Motor switchover

Set P05.01–P05.08, P05.11, or P08.31 to switch between two sets of motor parameters. There are two switching methods.

Method 1 Switching through multifunction digital input terminal function setting

Set any one terminal function from P05.01–P05.08 or P05.11 to 32.

| Function code | Name | Default | Setting range | Description |
|---------------|-------------------------------------|---------|---------------|---|
| P05.01–P05.08 | DI1–DI8 terminal function selection | 1 | 0–95 | 32: Motor switchover Note: DI5–DI8 are virtual terminals enabled by P05.16 and can only be modified through communication. For Modbus/Modbus TCP communication, the virtual terminal address is 0x200A. For other communication protocols, see the PZD receiving function code options. |
| | | 4 | | |
| | | 7 | | |
| | | 0 | | |
| | | 0 | | |
| | | 0 | | |
| | | 0 | | |
| P05.11 | Function of HD11 | 0 | | |

Method 2 Switch through communication

Set the ones place of P08.31 to a value greater than zero, and select any channel to switch between motor 1 and motor 2. For example, during Modbus/Modbus TCP communication, it is switched by bit 0 of address 2009H. For other communication methods, see their corresponding control words.

| Function code | Name | Default | Setting range | Description |
|---------------|----------------------------|---------|---------------|--|
| P08.31 | Motor switchover selection | 0x00 | 0x00–0x14 | Ones place: Switchover channel 0: Terminal 1: Modbus/Modbus TCP communication 2: Reserved 3: Ethernet 4: EtherCAT/PROFINET/EtherNet |

| Function code | Name | Default | Setting range | Description |
|---------------|------|---------|---------------|--|
| | | | | IP communication Tens place: indicates whether to enable switchover during running 0: Disable 1: Enable |

6.2 Parameter autotuning setting

To improve motor control effect, you are recommended to set motor rated parameters according to the motor nameplate after the first power on, and then conduct parameter autotuning. The VFD parameter autotuning includes motor parameter autotuning and motor inertia autotuning. You can select an autotuning mode based on actual conditions.

6.2.1 Motor parameter autotuning

Motor parameters have a significant impact on the calculation of the control model, especially in the case of vector control, which requires motor parameter autotuning first.

After setting motor parameters, you can set P00.15 to select the autotuning method. The setting procedure is as follows:

Step 1 Set P00.01 to 0 to select the keypad.

Step 2 Set P00.15 to select one method from the three motor parameter autotuning methods. Set P00.15 to a value greater than 0 and press **ENT/SHIFT** for confirmation. Then the keypad displays "-TUN-".

Step 3 Press **RUN** to give the start command. The VFD enters parameter autotuning, during which the autotuning steps are displayed. For example, at autotuning step 1, the keypad displays "TUN-1". Once the autotuning is complete, the keypad displays "-End-".

| Function code | Name | Default | Setting range | Description |
|---------------|----------------------------|---------|---------------|---|
| P00.15 | Motor parameter autotuning | 0 | 0-3 | 0: No operation 1: Complete parameter rotary autotuning 2: Complete parameter static autotuning 3: Partial parameter static autotuning |

Note:

- When P00.15 is set to 1, disconnect the motor from the load to put the motor in static and no-load state.
- When P00.15 is set to 2 or 3, there is no need to disconnect the motor from the load.
- Motor autotuning can be carried out on the present motor only. If you need to perform autotuning on the other motor, switch the motor first.

Table 6-1 Motor parameters obtained in different autotuning methods

| Setting of P00.15 | Autotuning parameters | | | |
|-------------------|-----------------------|---------------|---------------|---------------|
| | AM 1 | AM 2 | SM 1 | SM 2 |
| 1 | P02.06–P02.14 | P34.06–P34.14 | P02.20–P02.23 | P34.20–P34.23 |
| 2 | P02.06–P02.10 | P34.06–P34.10 | P02.20–P02.22 | P34.20–P34.22 |
| 3 | P02.06–P02.08 | P34.06–P34.08 | | |

Note: The synchronous motor back-EMF constant P02.23/P34.23 can also be calculated based on the parameters on the motor nameplate, and there are three calculation methods.

Method 1: If the back-EMF coefficient K_e is marked on the nameplate, the calculation is as follows:

$$E=(K_e * n_N * 2\pi)/60$$

Method 2: If the back-EMF E' (unit: V/1000r/min) is marked on the nameplate, the calculation is as follows:

$$E=E' * n_N / 1000$$

Method 3: If none of the two preceding parameters is marked on the nameplate, the calculation is as follows:

$$E=P/(\sqrt{3} * I)$$

In the preceding formulas, " n_N " indicates the rated rotation speed, " P " indicates the rated power, and " I " indicates the rated current.

6.2.2 Motor inertia identifying

Inertia identifying is applicable to the scenarios where large inertia exists and speed dynamic response follows up well in the vector control mode. Inertia identifying is required before inertia compensation enabling. During the identifying process, the VFD controls the automatic start and stop of the motor and prompts for autotuning completion. Set P03.44 (Motor 2 inertia identifying is specified by function code P35.44) for motor inertia identifying as follows:

Step 1 Set P00.01 to 0 to select the keypad.

Step 2 Set P03.44 to 1 for enabling.

Step 3 After the RUN key is pressed to give the VFD start command, the VFD starts inertia identifying and automatically controls the motor start and stop.

| Function code | Name | Default | Setting range | Description |
|---------------|---|---------|------------------------------------|---|
| P03.43 | Motor 1 inertia identification torque | 10.0% | 0.0–100.0% (Motor rated torque) | Due to friction force, it is required to set certain identification torque for the inertia identification to be performed properly. |
| P35.43 | Motor 2 inertia identification torque | | | |
| P03.44 | Enabling motor 1 inertia identification | 0 | 0–1 | 0: Disable 1: Enable |
| P35.44 | Enabling motor 2 inertia identification | | | |

 **Note:** If the motor is running at low speed for a long time, which indicates that P03.43 (Inertia identification torque) is set too low, perform manual stop, increase the value of P03.43, and execute inertia identification again.

6.3 Running command selection

Running commands are used to control the start, stop, forward running reverse running, and jogging of the VFD. The channels of running commands include keypad, terminal, and communication. Set P00.01 to select a channel of running commands.

| Function code | Name | Default | Setting range | Description |
|---------------|-----------------------------|---------|---------------|--|
| P00.01 | Channel of running commands | 0 | 0–2 | 0: Keypad 1: Terminal 2: Communication |

Keypad

When P00.01 is set to 0, you can control the VFD start or stop through the keypad key **RUN** or **STOP/RST**. After pressing the **RUN** key, the VFD starts running, and the **RUN** indicator turns on. In running state, if you press the **STOP/RST** key, the VFD stops running, and the **RUN** indicator turns off. For details about keypad operations, see chapter 5 Keypad operation guidelines.

Terminal

When P00.01 is set to 1, you can control the VFD start or stop through terminals. The setting procedure is as follows:

Step 1 Set P05.01–P05.08 and P05.11 to the required running commands. For example, if you need to set DI2 to reverse running, set P05.02 to 2.

| Function code | Name | Default | Setting range | Description |
|-------------------|--|---------|---------------|---|
| P05.01– P05.08 | DI1–DI8 terminal function selection | 1 | 0–95 | 1: Run forward (FWD) |
| | | 4 | | 2: Run reversely (REV) |
| | | 7 | | 3: Three-wire running control (D _{in}) |
| | | 0 | | 4: Jog forward |
| | | 0 | | 5: Jog reversely |
| | | 0 | | 6: Coast to stop |
| | | 0 | | 7: Reset faults |
| | | 0 | | ⚡ Note: DI5–DI8 are virtual terminals enabled by P05.16 and can only be modified through communication. For Modbus/Modbus TCP communication, the virtual terminal address is 0x200A. For other communication protocols, see the PZD receiving function code options. |
| P05.11 | Function of HDI1 | 0 | | |

Step 2 Set P05.17 to select the terminal control mode.

| Function code | Name | Default | Setting range | Description |
|---------------|-----------------------|---------|---------------|--|
| P05.17 | Terminal control mode | 0 | 0–3 | 0: Two-wire control mode 1 1: Two-wire control mode 2 2: Three-wire control mode 1 3: Three-wire control mode 2 |

Two-wire control mode 1: P05.17=0

The enabling is combined with the direction. This mode is widely used. The defined FWD/REV terminal command determines the motor rotation direction.

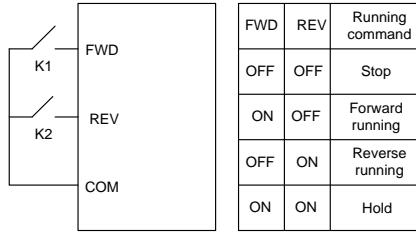

Two-wire control mode 2: P05.17=1

The enabling separated from the direction. In this mode, FWD is the enabling terminal. The direction depends on the defined REV state.

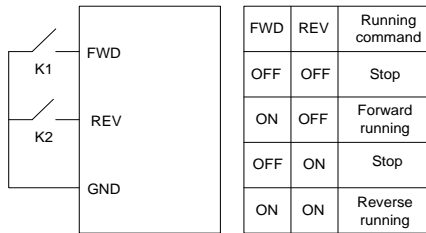

Three-wire control mode 1: P05.17=2

This mode defines DI_{in} as the enabling terminal, and the running command is generated by FWD, while the direction is controlled by REV. During running, the DI_{in} terminal needs to be closed, and when terminal FWD generates a rising edge signal, the VFD starts to run in the direction set by the state of terminal REV; the VFD needs to be stopped by disconnecting terminal DI_{in}.

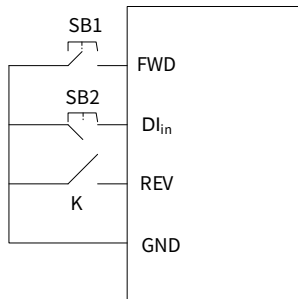

The direction control is as follows during running:

| DI _{in} | REV | Previous direction | Present direction |
|------------------|--------|--------------------|-------------------|
| ON | OFF→ON | FWD run | REV run |
| | | REV run | FWD run |

| DI _{in} | REV | Previous direction | Present direction |
|------------------|--------|--------------------|-------------------|
| ON | ON→OFF | REV run | FWD run |
| | | FWD run | REV run |
| ON→OFF | ON | Decelerate to stop | |
| | OFF | | |

Three-wire control mode 2: P05.17=3

This mode defines DI_{in} as the enabling terminal, and the running command is generated by FWD or REV, but the direction is controlled by both FWD and REV. During running, the DI_{in} terminal needs to be closed, and terminal FWD or REV generates a rising edge signal to control the running and direction of the VFD; the VFD needs to be stopped by disconnecting terminal DI_{in}.

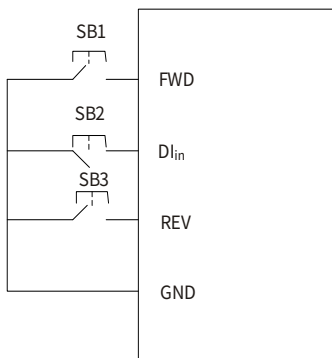

The direction control is as follows during running:

| DI _{in} | FWD | REV | Running direction |
|------------------|--------|--------|--------------------|
| ON | OFF→ON | ON | FWD run |
| | | OFF | FWD run |
| ON | ON | OFF→ON | REV run |
| | OFF | | REV run |
| ON→OFF | - | - | Decelerate to stop |

Note: For two-wire controlled running mode, when the FWD/REV terminal is valid, if the VFD stops due to a stop command given by another source, the VFD does not run again after the stop command disappears even if the control terminal FWD/REV is still valid. To make the VFD run, you need to trigger FWD/REV again, for example, PLC single-cycle stop, fixed-length stop, and valid STOP/RST stop during terminal control. (See P07.04.)

Communication

When P00.01 is set to 2, you can control the VFD start or stop by setting commands

through communication. For details, see chapter 7 Communication.

| Function code | Name | Default | Setting range | Description |
|---------------|--|---------|---------------|---|
| P00.02 | Communication mode of running commands | 0 | 0-6 | 0: Modbus/Modbus TCP 2: Ethernet 3: EtherCAT/PROFINET/EtherNet IP Others: Reserved |

6.4 Frequency setting

The VFD supports multiple kinds of frequency reference modes, which can be categorized into two types: main reference channel and auxiliary reference channel.

There are two main reference channels, namely frequency reference channel A and frequency reference channel B. These two channels support simple arithmetical operation between each other, and they can be switched dynamically.

There is one auxiliary reference channel, namely the UP/DOWN terminal. By setting P08.46, you can enable the reference mode corresponding to the UP/DOWN terminal and its effect on the VFD frequency reference.

The actual VFD reference is comprised of the main reference channel and auxiliary reference channel. The schematic diagram is as follows:

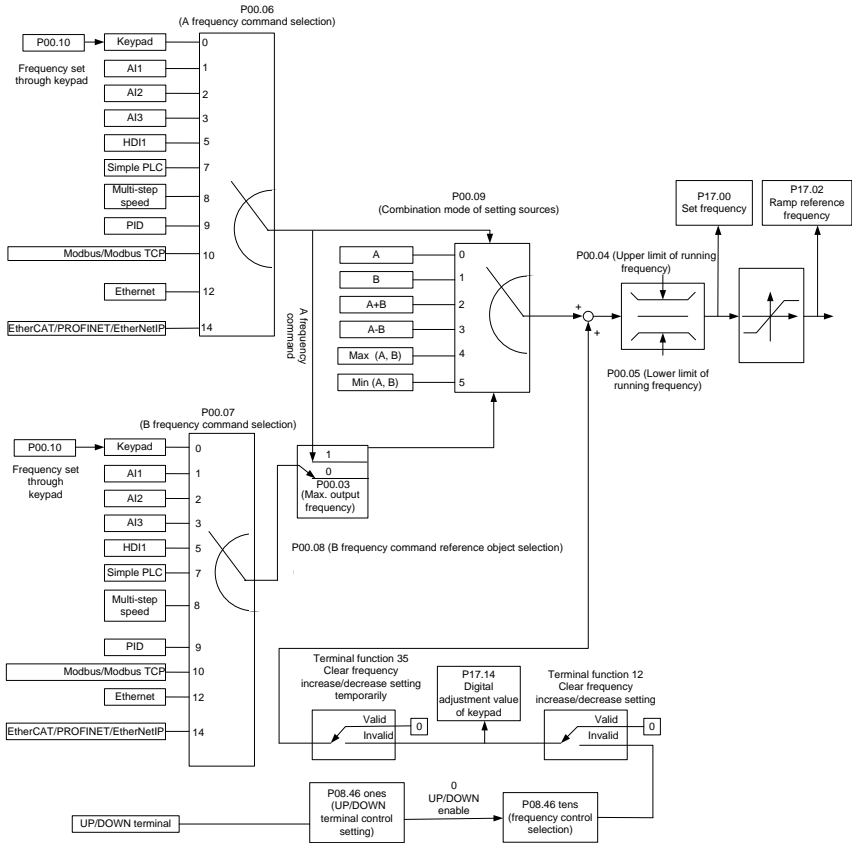

When P05.01 or P05.02 is 10 or 11, DI1 or DI2 is the UP or DOWN terminal. When DI1 or DI2 is closed, the reference frequency will be fast increased or decreased. The increase or decrease rate is determined by P08.47 or P08.48. See the following figure.

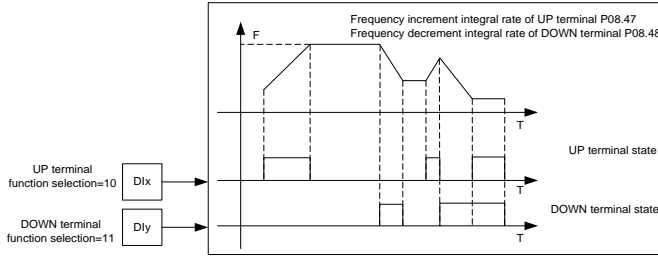

6.4.1 Combination of frequency setting source

6.4.1.1 Combination mode of setting source

Set P00.09 to select the combination mode of setting source.

| Function code | Name | Default | Setting range | Description |
|---------------|------------------------------------|---------|---------------|---|
| P00.09 | Combination mode of setting source | 0 | 0-5 | 0: A 1: B 2: (A+B) 3: (A- B) 4: Max(A, B) 5: Min. (A, B) |

6.4.1.2 Frequency channel switchover

You can set any of function codes P05.01-P05.08 or P05.11 to any of functions 13-15 to switch frequency channels. The setting procedure is as follows:

- Step 1 Select any one of multifunction digital input terminals DI1-DI8, and HDI1 as an external input terminal.
- Step 2 Set P05.01-P05.08 and P05.11 to any one of 13-15.

| Function code | Name | Default | Setting range | Description |
|---------------|-----------------------------|---------|---------------|--|
| P05.01-P05.08 | Terminal function selection | 1 | 0-95 | 13: Switch between A setting and B setting 14: Switch between combination setting and A setting 15: Switch between combination setting and B setting |
| | | 4 | | |
| | | 7 | | |
| | | 0 | | |
| | | 0 | | |
| | | 0 | | |
| | | 0 | | |

| Function code | Name | Default | Setting range | Description |
|---------------|------------------|---------|---------------|-------------|
| | | 0 | | |
| P05.11 | Function of HDI1 | 0 | | |

The combinations are described in the following table:

| Present reference channel P00.09 | Multifunction digital input terminal function 13 (Switch from channel A to channel B) | Multifunction digital input terminal function 14 (Switch from combined setting to channel A) | Multifunction digital input terminal function 15 (Switch from combined setting to channel B) |
|----------------------------------|---|--|--|
| A | B | - | - |
| B | A | - | - |
| A+B | - | A | B |
| A-B | - | A | B |
| Max(A, B) | - | A | B |
| Min(A, B) | - | A | B |

6.4.2 Frequency setting method

The VFD provides multiple frequency setting methods. You can set P00.06 and P00.07 to select the A and B frequency channel setting methods.

| Function code | Name | Default | Setting range | Description |
|---------------|--|---------|---------------|--|
| P00.06 | Setting channel of A frequency command | 0 | 0-15 | 0: P00.10 1: AI1 2: AI2 3: AI3 |
| P00.07 | Setting channel of B frequency command | 1 | | 5: High-speed pulse HDI1 7: Simple PLC program 8: Multi-step speed running 9: PID control 10: Modbus/Modbus TCP communication 12: Ethernet communication 14: EtherCAT/PROFINET/EtherNet IP communication Others: Reserved |

6.4.2.1 Setting frequency through keypad

When P00.06 or P00.07 (Setting channel of A or B frequency command) is set to 0 (keypad digital as the setting channel), and P00.10 specifies the original value of the digital setting based VFD frequency.

| Function code | Name | Default | Setting range | Description |
|---------------|----------------------------------|---------|---------------|--|
| P00.10 | Setting frequency through keypad | 50.00Hz | 0.00Hz–P00.03 | P00.03 specifies the max. output frequency. When the setting channel of A and B frequency commands is keypad, P00.10 specifies the original value of the digital setting based VFD frequency. |

6.4.2.2 Setting frequency through analog

You can set P00.06 or P00.07 to 1, 2, or 3 (setting frequency through analog). For details, see section 6.9.2 Analog input and output terminal functions.

6.4.2.3 Setting frequency through high-speed pulse HDI

You can set P00.06 or P00.07 to 5 (setting frequency through high-speed pulse).

6.4.2.4 Setting frequency through simple PLC

You can set P00.06 or P00.07 to 7 (setting frequency through simple PLC).

Simple PLC is a multi-step speed generator, and the VFD can change the running frequency and direction automatically based on the running time to fulfill process requirements. The VFD can realize 16-step speed control, and provide four groups of acceleration/deceleration time for selection. After the set PLC completes one cycle (or one step), one ON signal can be output by the multifunction relay. See the following figure.

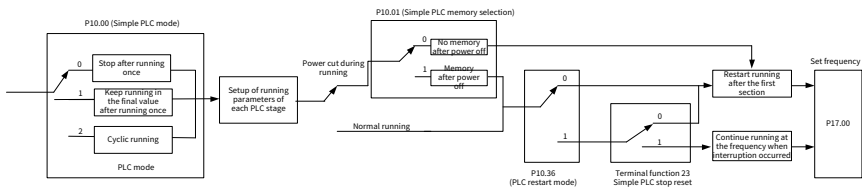

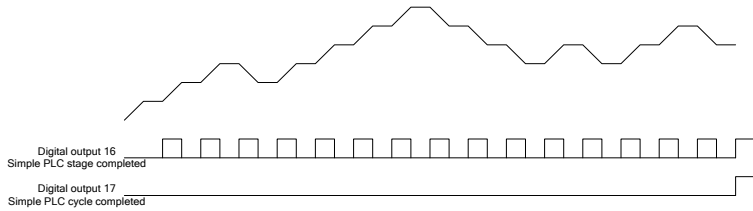

When simple PLC is selected for frequency giving, you need to set P10.02–P10.33 to determine the running frequency and running time of each step. The schematic diagram is as follows:

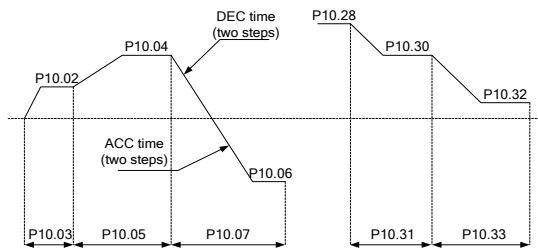

Note: The sign of multi-step speed determines the running direction of simple PLC, and a negative value means reverse running. ACC time indicates the time needed for the VFD to accelerate from 0Hz to the max. output frequency (P00.03). DEC time means the time needed if the VFD speeds down from the max. output frequency (P00.03) to 0Hz. Select corresponding acceleration/deceleration time, and then convert 16-bit binary number into hexadecimal number, finally, and then set corresponding function codes.

| Function code | Name | Default | Setting range | Description |
|---------------|------------|----------------|---------------|--|
| P00.11 | ACC time 1 | Model depended | 0.0–3600.0s | The VFD has four groups of ACC/DEC time, which can be selected by multifunction digital input terminal function 21 or 22 (specified by P05). The factory default ACC/DEC time of the VFD is the first group. |
| P00.12 | DEC time 1 | Model depended | | |
| P08.00 | ACC time 2 | Model depended | | |
| P08.01 | DEC time 2 | Model depended | | |
| P08.02 | ACC time 3 | Model depended | | |
| P08.03 | DEC time 3 | Model depended | | |

| Function code | Name | Default | Setting range | Description |
|---------------|--|----------------|---------------|---|
| P08.04 | ACC time 4 | Model depended | | |
| P08.05 | DEC time 4 | Model depended | | |
| P10.34 | ACC/DEC time of steps 0–7 of simple PLC | 0x0000 | 0x0000–0xFFFF | Select corresponding acceleration/deceleration time, and then convert 16-bit binary number into hexadecimal number, finally, and then set corresponding function codes. For details, see the following table. |
| P10.35 | ACC/DEC time of steps 8–15 of simple PLC | 0x0000 | | |

The description is as follows:

| Function code | Binary | | Step | ACC/DEC time 1 | ACC/DEC time 2 | ACC/DEC time 3 | ACC/DEC time 4 |
|---------------|--------|-------|------|----------------|----------------|----------------|----------------|
| P10.34 | Bit1 | Bit0 | 0 | 00 | 01 | 10 | 11 |
| | Bit3 | Bit2 | 1 | 00 | 01 | 10 | 11 |
| | Bit5 | Bit4 | 2 | 00 | 01 | 10 | 11 |
| | Bit7 | Bit6 | 3 | 00 | 01 | 10 | 11 |
| | Bit9 | Bit8 | 4 | 00 | 01 | 10 | 11 |
| | Bit11 | Bit10 | 5 | 00 | 01 | 10 | 11 |
| | Bit13 | Bit12 | 6 | 00 | 01 | 10 | 11 |
| | Bit15 | Bit14 | 7 | 00 | 01 | 10 | 11 |
| P10.35 | Bit1 | Bit0 | 8 | 00 | 01 | 10 | 11 |
| | Bit3 | Bit2 | 9 | 00 | 01 | 10 | 11 |
| | Bit5 | Bit4 | 10 | 00 | 01 | 10 | 11 |
| | Bit7 | Bit6 | 11 | 00 | 01 | 10 | 11 |
| | Bit9 | Bit8 | 12 | 00 | 01 | 10 | 11 |
| | Bit11 | Bit10 | 13 | 00 | 01 | 10 | 11 |
| | Bit13 | Bit12 | 14 | 00 | 01 | 10 | 11 |
| | Bit15 | Bit14 | 15 | 00 | 01 | 10 | 11 |

6.4.2.5 Setting frequency through multi-step speed commands

You can set P00.06 or P00.07 to 8 (setting frequency through multi-step speed commands). It is applicable to scenarios where the VFD running frequency does not need to be adjusted continuously and only a number of frequency values are needed.

The VFD supports the setting of 16-step speed, which are set by combined codes of multi-step terminals 1–4 set by DI terminals, corresponding to function code P05.01–P05.11) and correspond to multi-step speed 0 to multi-step speed 15.

When terminal 1, terminal 2, terminal 3, and terminal 4 are OFF, the frequency input mode is set by P00.06 or P00.07. When terminal 1, terminal 2, terminal 3, and terminal 4 are not all OFF, the frequency set by multi-step speed will prevail, and the priority of multi-step setting is higher than that of the keypad, analog, high-speed pulse, PID, and communication settings.

Note: The sign of multi-step speed determines the running direction of simple PLC, and a negative value means reverse running. For details, see section 6.4.2.4 Setting frequency through simple PLC.

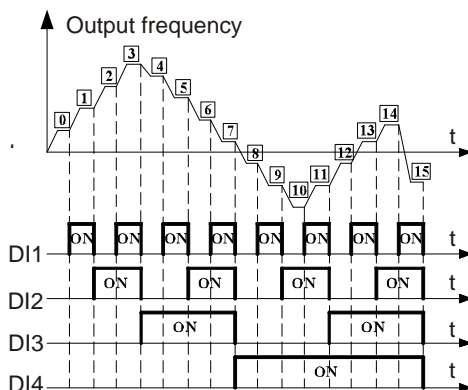

| | | | | | | | | |
|-------------------|----------|----------|-----------|-----------|-----------|-----------|-----------|-----------|
| Terminal 1 | OFF | ON | OFF | ON | OFF | ON | OFF | ON |
| Terminal 2 | OFF | OFF | ON | ON | OFF | OFF | ON | ON |
| Terminal 3 | OFF | OFF | OFF | OFF | ON | ON | ON | ON |
| Terminal 4 | OFF | OFF | OFF | OFF | OFF | OFF | OFF | OFF |
| Step | 0 | 1 | 2 | 3 | 4 | 5 | 6 | 7 |
| Terminal 1 | OFF | ON | OFF | ON | OFF | ON | OFF | ON |
| Terminal 2 | OFF | OFF | ON | ON | OFF | OFF | ON | ON |
| Terminal 3 | OFF | OFF | OFF | OFF | ON | ON | ON | ON |
| Terminal 4 | ON | ON | ON | ON | ON | ON | ON | ON |
| Step | 8 | 9 | 10 | 11 | 12 | 13 | 14 | 15 |

| Function code | Name | Default | Setting range | Description |
|---------------|------------------|---------|---------------|--|
| P05.01–P05.08 | DI1–DI8 terminal | 1 4 | 0–95 | 16: Multi-step speed terminal 1 17: Multi-step speed terminal 2 |

| Function code | Name | Default | Setting range | Description |
|---------------|---|------------|---------------------------|--|
| | function selection | 7 | | 18: Multi-step speed terminal 3 19: Multi-step speed terminal 4 20: Pause multi-step speed running |
| | | 0 | | |
| | | 0 | | |
| | | 0 | | |
| | | 0 | | |
| | | 0 | | |
| P05.11 | Function of HDI1 | 0 | | |
| P10.02–P10.32 | Multi-step speeds 0–15 and running time | 0.0% | Frequency: -300.0%–300.0% | The setting 100.0% corresponds to the max. output frequency (P00.03). |
| | | 0.0s (min) | Time: 0.0–6553.5s(min) | The time unit is specified by P10.37. |

6.4.2.6 Setting frequency through PID control

You can set P00.06 or P00.07 to 9 (setting frequency through PID control).

PID control, a common mode for process control, is mainly used to adjust the VFD output frequency or output voltage, thus forming a negative feedback system to keep the controlled variables above the target. It is applicable to flow control, pressure control, temperature control, and so on. The following is the basic schematic block diagram for output frequency regulation.

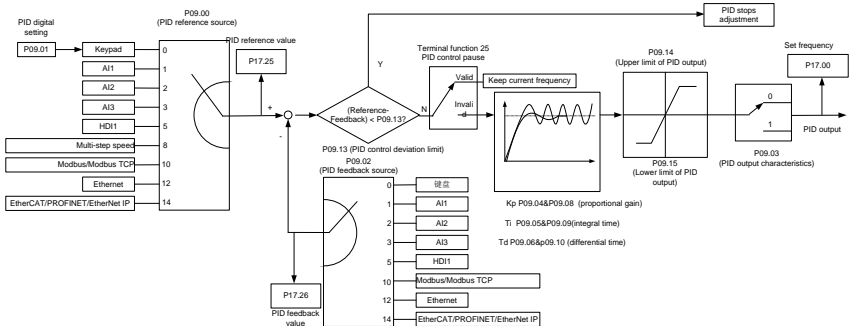

| Function code | Name | Default | Setting range | Description |
|---------------|----------------------|---------|---------------|--|
| P09.00 | PID reference source | 0 | 0–15 | When P00.06 or P00.07 (Setting channel of A or B frequency |

| Function code | Name | Default | Setting range | Description |
|---------------|-------------------------------|---------|----------------|---|
| | selection | | | <p>command) is 9 or P04.13 (Voltage setting channel) is 9, the VFD is process PID controlled.</p> <p>The function code determines the target given channel during the PID process.</p> <p>0: Setting through P09.01 1: AI1 2: AI2 3: AI3 5: High-speed pulse HDI1 8: Multi-step speed running 10: Modbus/Modbus TCP communication 12: Ethernet communication 14: EtherCAT/PROFINET/EtherNet IP communication Others: Reserved</p> <p>The set target of process PID is a relative value, for which 100% equals 100% of the feedback signal of the controlled system. The system always performs calculation by using a relative value (0-100.0%).</p> |
| P09.01 | PID digital setting | 0.0% | -100.0%-100.0% | <p>The function code is mandatory when P09.00=0. The base value of P09.01 is the feedback of the system.</p> |
| P09.02 | PID feedback source selection | 0 | 0-15 | <p>0: Setting through P09.01 1: AI1 2: AI2 3: AI3 5: High-speed pulse HDI1 10: Modbus/Modbus TCP communication 12: Ethernet communication</p> |

| Function code | Name | Default | Setting range | Description |
|---------------|--------------------------------------|---------|---------------|--|
| | | | | 14: EtherCAT/PROFINET/EtherNet IP communication Others: Reserved Note: The reference channel and feedback channel cannot be duplicated. Otherwise, effective PID control cannot be achieved. |
| P09.03 | PID output characteristics selection | 0 | 0-1 | 0: PID output is positive. When the feedback signal is greater than the PID reference value, the output frequency of the VFD will decrease to balance the PID. Example: PID control on strain during unwinding. 1: PID output is negative. When the feedback signal is greater than the PID reference value, the output frequency of the VFD will increase to balance the PID. Example: PID control on tension during unwinding |
| P09.04 | Low frequency proportional gain (Kp) | 1.00 | 0.00-100.00 | Low-frequency switching point: 5.00Hz, high-frequency switching point: 10.00Hz (P09.04 corresponds to high-frequency parameter), and the middle is the linear interpolation between these two points. |
| P09.05 | Low frequency integral time (Ti) | 0.90s | 0.00-10.00s | - |
| P09.06 | Low frequency differential time (Td) | 0.00s | 0.00-10.00s | - |
| P09.07 | Low frequency point for PID | 5.00Hz | 0.00Hz-P09.11 | - |

| Function code | Name | Default | Setting range | Description |
|---------------|--|---------|---------------|--|
| | parameter switching | | | |
| P09.08 | High frequency proportional gain (Kp) | 1.80 | 0.00–100.00 | - |
| P09.09 | High frequency integral time (Ti) | 0.90s | 0.00–10.00s | - |
| P09.10 | High frequency differential time (Td) | 0.00s | 0.00–10.00s | - |
| P09.11 | High frequency point for PID parameter switching | 10.00Hz | P09.07–P00.03 | - |
| P09.12 | Sampling period (T) | 0.001s | 0.000–1.000s | Used to indicate the sampling cycle of feedback. The regulator calculates in each sampling cycle. A longer sampling cycle indicates slower response. |
| P09.13 | PID control deviation limit | 0.0% | 0.0–100.0% | <p>Used to adjust the accuracy and stability of the PID system. The output value of the PID system is relative to the max. deviation of the closed loop reference. As shown in the following figure, the PID regulator stops regulating in the range of deviation limit.</p> |

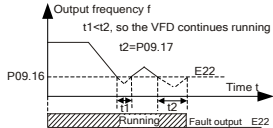
| Function code | Name | Default | Setting range | Description |
|---------------|----------------------------------|---------|--|--|
| P09.14 | PID output upper limit | 100.0% | P09.15–100.0% (Relative to the max. frequency) | Used to set the upper limit of PID regulator output values. |
| P09.15 | PID output lower limit | 0.0% | -100.0%–P09.14 (Relative to the max. frequency) | Used to set the lower limit of PID regulator output values. |
| P09.16 | Feedback offline detection value | 0.0% | 0.0–100.0% | When the feedback value is smaller than or equal to the feedback offline detection value, and the duration exceeds the value specified by P09.17, the VFD reports "PID feedback offline fault", and the keypad displays "E22".  |
| P09.17 | Feedback offline detection time | 1.0s | 0.0–3600.0s | |
| P09.18 | PID control selection | 0x0001 | 0x0000–0x1111 | <p>Ones place:</p> <ul style="list-style-type: none"> 0: Continue integral control after the frequency reaches upper/lower limit 1: Stop integral control after the frequency reaches upper/lower limit <p>Tens place:</p> <ul style="list-style-type: none"> 0: Same as the main reference direction 1: Contrary to the main reference direction <p>Hundreds place:</p> <ul style="list-style-type: none"> 0: Limit as per the max. frequency 1: Limit as per A frequency <p>Thousands place:</p> <ul style="list-style-type: none"> 0: A+B frequency. ACC/DEC of main reference A frequency |

| Function code | Name | Default | Setting range | Description |
|---------------|-----------------------------|---------|---------------|--|
| | | | | source pre-charging is invalid. 1: A+B frequency, acceleration/ deceleration of main reference A frequency source pre-charging is valid, acceleration/deceleration is determined by P08.04 (acceleration time 4). |
| P09.19 | ACC/DEC time of PID command | 0.0s | 0.0–1000.0s | - |
| P09.20 | PID output filter time | 0.000s | 0.000–10.000s | - |
| P17.00 | Set frequency | 0.00Hz | 0.00Hz–P00.03 | - |
| P17.25 | PID reference value | 0.0% | -100.0–100.0% | - |
| P17.26 | PID feedback value | 0.0% | -100.0–100.0% | - |

■ Introduction to the working principles and control methods for PID control

Proportional regulation (Kp)

Proportional control can respond to feedback changes rapidly, however, it cannot eliminate the static difference by itself. A larger proportional gain indicates a faster regulating speed, but a too large gain will result in oscillation. To solve this problem, set the integral time to a large value and the differential time to 0 to run the system, and then change the reference to observe the difference (that is, static difference) between the feedback signal and reference. If the static difference occurs in the direction of reference change (such as reference increase, where the feedback is always less than the reference after system stabilizes), continue increasing the proportional gain; otherwise, decrease the proportional gain. Repeat this process until the static difference becomes small.

| Function code | Name | Description |
|----------------|------------------------|--|
| P09.04, P09.08 | Proportional gain (Kp) | The function is applied to the proportional gain P of PID input. P determines the strength of the whole PID regulator. The larger the value of P, the stronger the adjustment intensity. The value 100 indicates that when the difference between the PID feedback value and given value is 100%, the range within which the PID regulator can regulate the output frequency command is the max. frequency |

| Function code | Name | Description |
|---------------|------|---|
| | | (ignoring integral function and differential function). |

Integral time (Ti)

The integral adjuster can be used to eliminate static difference. Too large regulation may lead to system oscillation. The integral time parameter is generally regulated gradually from large to small until the stabilized system speed fulfills the requirement.

| Function code | Name | Description |
|-------------------|-----------------------|---|
| P09.05, P09.09 | Integral time (Ti) | Used to determine the speed of the integral adjustment on the deviation of PID feedback and reference from the PID regulator. When the deviation between PID feedback and reference is 100%, the integral regulator works continuously during the time to achieve the max. output frequency (P00.03) or the max. voltage (P04.17). Shorter integral time indicates stronger adjustment. |

Differential time (Td)

Differential control is used to control the feedback signal variation based on the change trend. Exercise caution before using the differential regulator since it may enlarge the system interferences, especially those with high change frequency.

| Function code | Name | Description |
|-------------------|------------------------|---|
| P09.06, P09.10 | Differential time (Td) | Used to determine the strength of the change ratio adjustment on the deviation of PID feedback and reference from the PID regulator. If the feedback changes 100% during the time, the adjustment of the differential regulator is the max. output frequency (P00.03) or the max. voltage (P04.17). Longer differential time indicates stronger adjustment. |

■ How to fine-tune PID

After setting the parameters controlled by PID, you can adjust these parameters by the following means.

Control overshoot

When overshoot occurred, shorten the derivative time (T_d) and prolong integral time (T_i).

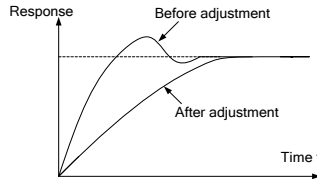

Stabilize the feedback value as fast as possible

When overshoot occurred, shorten integral time (T_i) and prolong derivative time (T_d) to stabilize control as fast as possible.

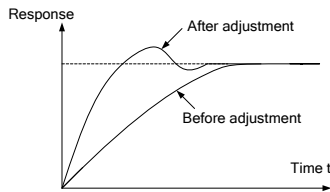

Control long-term oscillation

If the cycle of periodic oscillation is longer than the set value of integral time (T_i), it indicates the integral action is too strong, prolong the integral time (T_i) to control oscillation.

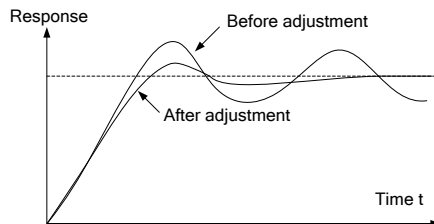

Control short-term oscillation

If the oscillation cycle is as short almost the same as the set value of differential time (T_d), it indicates the differential action is too strong. Shorten the differential time (T_d) to control oscillation. When the differential time (T_d) is set to 0.00 (namely no differential

control), and there is no way to control oscillation, decrease the proportional gain.

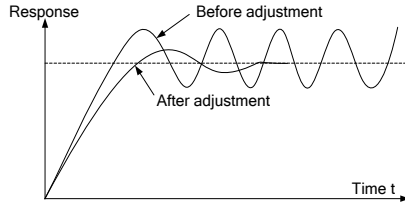

6.4.2.7 Frequency set through communication

You can set P00.06 or P00.07 to 10, 12, or 14 (Setting frequency through communication). For details, see chapter 7 Communication.

6.4.3 Frequency fine-tuning

The VFD supports frequency fine-tuning based on the set frequency. In some special scenarios, the set frequency can be set to 0, and the frequency fine-tuning function can be used for frequency setting during the whole process.

Step 1 Select any one of multifunction digital input terminals DI1–DI8, and HDI1 as an external input terminal.

Step 2 Set P05.01–P05.08 and P05.11 to 10 or 11.

| Function code | Name | Default | Setting range | Description |
|---------------|-------------------------------------|---------|---------------|--|
| P05.01–P05.08 | DI1–DI8 terminal function selection | 1 | 0–95 | 10: Increase frequency setting (UP) 11: Decrease frequency setting (DOWN) |
| | | 4 | | |
| | | 7 | | |
| | | 0 | | |
| | | 0 | | |
| | | 0 | | |
| | | 0 | | |
| | | 0 | | |
| P05.11 | Function of HDI1 | 0 | | |
| P08.46 | UP/DOWN terminal control setting | 0x000 | 0x000–0x221 | Ones place: Frequency setting selection 0: The setting made through UP/DOWN is valid. 1: The setting made through UP/DOWN is invalid. Tens place: Frequency control |

| Function code | Name | Default | Setting range | Description |
|---------------|--|----------|---------------|---|
| | | | | selection 0: Valid only when P00.06=0 or P00.07=0 1: Valid for all frequency setting methods 2: Invalid for multi-step speed running when multi-step speed running has the priority Hundreds place: Action selection for stop 0: Setting is valid. 1: Valid during running, cleared after stop 2: Valid during running, cleared after a stop command is received |
| P08.47 | Frequency integral rate of the UP terminal | 0.50Hz/s | 0.01-50.00 | - |
| P08.48 | Frequency integral rate of the DOWN terminal | 0.50Hz/s | 0.01-50.00 | - |

6.5 Speed control mode selection

The VFD supports three speed control modes. You can set P00.00 to select a speed control mode based on actual conditions. Before using a vector control mode (0 or 1), set the motor nameplate parameters and perform motor parameter autotuning first. For details, see sections 6.1.2 Rated motor parameter setting and 6.2.1 Motor parameter autotuning.

| Function code | Name | Default | Setting range | Description |
|---------------|--------------------|---------|---------------|--|
| P00.00 | Speed control mode | 2 | 0-2 | 0: SVC mode 0 1: SVC mode 1 2: Space voltage vector control mode |

SVC mode 0: P00.00=0

In this case, there is no need to install encoders. It is applicable to scenarios with requirements for low frequency, great torque, and high speed control accuracy. It implements precise control of speed and torque. Compared to the SVC mode 1, this mode is more suitable for medium and small power applications. For details, see Group P03—Vector control of motor 1 and Group P35—Vector control of motor 2.

Note: The SM in this mode is applicable to large-power low frequency running rather than ultra-high speed running.

SVC mode 1: P00.00=1

In this case, there is no need to install encoders. It is applicable to scenarios that require high speed control accuracy. It can be used across all power ranges, enabling precise control of speed and torque. For details, see Group P03—Vector control of motor 1 and Group P35—Vector control of motor 2.

Space voltage vector control mode: P00.00=2

In this case, there is no need to install encoders. It can improve the control accuracy with the advantages of stable operation, valid low-frequency torque boost and current vibration suppression and the functions of slip compensation and voltage adjustment. For details, see Group P04—V/F control of motor 1 and Group P36—V/F control of motor 2.

6.6 Torque setting method selection

The VFD supports torque control and speed control. Speed control aims to stabilize the speed to keep the set speed consistent with the actual running speed, meanwhile, the max. load-carrying capacity is restricted by the torque limit. Torque control aims to stabilize the torque to keep the set torque consistent with the actual output torque, meanwhile, the output frequency is restricted by the upper and lower limits. The following uses torque mode setting for motor 1 as an example. For details, see Group P03—Vector control of motor 1. The torque mode setting for motor 2 is similar to that for motor 1. For details, see Group P35—Vector control of motor 2.

6.6.1 Torque setting method selection

You can set P03.11 to select a torque setting method. The torque setting adopts a relative value, 100% corresponds to the motor rated current, and the setting range is -300.0%–300.0%. After giving the start command to the VFD, the VFD runs in the forward direction when the torque reference value is positive and in the reverse direction when the torque reference value is negative.

| Function code | Name | Default | Setting range | Description |
|---------------|--|---------|----------------|--|
| P03.11 | Torque setting method selection of motor 1 | 0 | 0–15 | 0: P03.12 1: AI1 2: AI2 3: AI3 5: High-speed pulse HDI1 8: Multi-step speed running 10: Modbus/Modbus TCP communication 12: Ethernet communication 14: EtherCAT/PROFINET/EtherNet IP communication Others: Reserved |
| P03.12 | Torque set through keypad of motor 1 | 20.0% | -300.0%–300.0% | Torque setting is a relative value.  Note: 100% corresponds to the motor rated current. |
| P03.13 | Torque reference filter time of motor 1 | 0.010s | 0.000–10.000s | - |

6.6.2 Method for switching between speed control and torque control

There are three switching methods for speed control and torque control.

Method 1 Enable control switching

Set P03.32 to 0 for speed control or 1 for torque control.

Method 2 Switch signal through multifunction digital input terminal selection

The multifunction digital input terminal signal switching procedure is as follows:

Step 1 Select any one of multifunction digital input terminals DI1–DI8, and HDI1 as an external input terminal.

Step 2 Set P05.01–P05.08 and P05.11 to 29.

When function 29 is valid, set P03.32 to 0 for torque control or 1 for speed control.

Method 3 Switch through communication

Bit 2 of the VFD special control command word (address 2009H) is written to 1 through

the RS485 master station to enable the switching between torque and speed control.

When the communication based switching is effective, if P03.32 is set to 0, torque control is selected, and if P03.32 is set to 1, speed control is selected.

Note: When the terminal for switching speed control and torque control is valid, the control enabling selection is the opposite of that selected in P03.32.

| Function code | Name | Default | Setting range | Description |
|-------------------|--|---------|---------------|---|
| P03.32 | Enabling torque control of motor 1 | 0 | 0-1 | 0: Disable 1: Enable |
| P05.01- P05.08 | DI1-DI8 Terminal function selection | 1 | 0-95 | 29: Switch between speed control and torque control |
| | | 4 | | |
| | | 7 | | |
| | | 0 | | |
| | | 0 | | |
| | | 0 | | |
| | | 0 | | |
| | | 0 | | |
| | | 0 | | |
| P05.11 | Function of HDI1 | 0 | | |

6.7 Start/stop settings

6.7.1 Start settings

For a specific motor type and application scenario, you can select a start mode by setting P01.00.

| Function code | Name | Default | Setting range | Description |
|---------------|-----------------------|---------|---------------|--|
| P01.00 | Running mode of start | 0 | 0-4 | 0: Direct start 1: Start after DC braking 4: Start after speed tracking (software) Others: Reserved |

Direct start: P01.00=0

If the braking time before start is 0, the VFD runs at the starting frequency of direct start P01.01. This is often applicable to start from a still state. See the following figure.

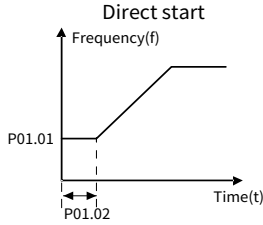

Start after DC braking: P01.00=1

If the DC braking time is not 0, enable the motor to keep at a position by means of DC braking, and then perform ACC start. This is applicable to the scenarios with the motor in slight rotation before start. See the following figure.

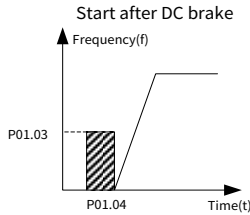

Start after speed tracking: P01.00= 4

The VFD searches for the current running frequency and direction of the motor and then controls the motor to run from the current frequency to the set frequency, implementing smooth running without impact. This is applicable to the scenarios with the motor in high-speed rotation or with transient grid voltage drop. See the following figure.

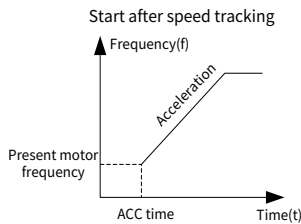

| Function code | Name | Default | Setting range | Description |
|---------------|------------------------------------|---------|---------------|---|
| P01.01 | Starting frequency of direct start | 0.50Hz | 0.00Hz–P00.03 | The function code indicates the initial frequency during VFD start. See P01.02 (Starting frequency hold time) for detailed information. |

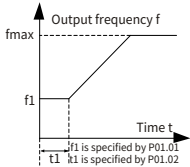
| Function code | Name | Default | Setting range | Description |
|---------------|------------------------------|---------|---------------|---|
| P01.02 | Starting frequency hold time | 0.0s | 0.0–50.0s | <p>Setting a proper starting frequency can increase the torque during VFD start. During the hold time of the starting frequency, the output frequency of the VFD is the starting frequency. And then, the VFD runs from the starting frequency to the set frequency. If the set frequency is lower than the starting frequency, the VFD stops running and keeps in the standby state. The starting frequency is not limited in the lower limit frequency.</p>  |
| P01.03 | Braking current before start | 0.0% | 0.0–100.0% | <p>The VFD performs DC braking with the braking current before start and it speeds up after the DC braking time. If the set DC braking time is 0, DC braking is invalid. Stronger braking current indicates larger braking power. The DC braking current before start is a percentage of the VFD rated output current.</p> |
| P01.04 | Braking time before start | 0.00s | 0.00–50.00s | |
| P01.23 | Start delay time | 0.0s | 0.0–600.0s | <p>After a VFD running command is given, the VFD is in standby state and restarts with the 起动 delay to implement brake release.</p> |

6.7.2 Stop settings

You can select a stop mode by setting P01.08.

| Function code | Name | Default | Setting range | Description |
|---------------|-----------|---------|---|-------------|
| P01.08 | Stop mode | 0 | 0: Decelerate to stop 1: Coast to stop | - |

Decelerate to stop: P01.08=0

After a stop command takes effect, the VFD lowers output frequency based on the DEC mode and the defined DEC time; after the frequency drops to the stop speed (P01.15), the VFD stops.

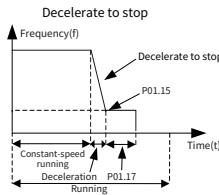

Coast to stop: P01.08=1

After a stop command takes effect, the VFD stops output immediately. And the load coasts to stop according to mechanical inertia.

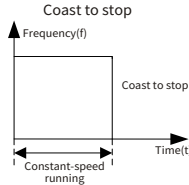

Note: If the set frequency is changed from higher than the frequency lower limit to lower than the frequency lower limit, the VFD takes the action specified by P01.19.

| Function code | Name | Default | Setting range | Description |
|---------------|--|---------|---------------|--|
| P01.19 | Action selected when running frequency less than frequency lower limit | 0x00 | 0x00-0x12 | Ones place: Action selection 0: Run at the frequency lower limit 1: Stop 2: Sleep Tens place: Stop mode 0: Coast to stop 1: Decelerate to stop |

If you need to achieve a fast and stable stop of the motor, the motor can be stopped by DC braking after reaching the low speed frequency specified by P01.09.

| Function code | Name | Default | Setting range | Description |
|---------------|--|---------|---------------|--|
| P01.09 | Starting frequency of braking for stop | 0.00Hz | 0.00Hz-P00.03 | P00.03 specifies the max. output frequency. During the deceleration to stop, the VFD starts DC braking for stop when the running frequency reaches the frequency specified by P01.09. |

P01.09 = Non-zero value

During decelerating to stop, if the running frequency of VFD is lower than the starting frequency of brake for stop (P01.09), the VFD waits for the demagnetization time P01.10 and checks the value of P01.12. If the value is a non-zero value, the VFD performs DC braking with the time specified by P01.12. When the DC braking time is reached, the VFD coasts to stop. If the value of P01.12 is zero, short-circuit braking for stop is invalid.

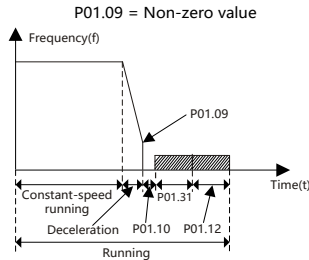

P01.09 = Zero

The VFD decelerates to stop according to the normal process. When the ramp frequency is less than P01.15, the VFD performs stop determination with a delay specified by P01.24 according to the mode specified by P01.16. If P01.16=0, the VFD coasts to stop. If P01.16=1, the VFD needs to check whether the motor output frequency is less than P01.15. If yes, the VFD coasts to stop. If no, the VFD coasts to stop with a delay specified by P01.17.

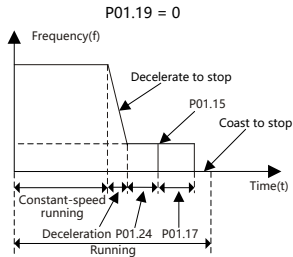

The methods for fast decelerating to stop are as follows:

Method 1 Increase the VFD power to improve the VFD max. braking capability.

Method 2 Decelerate to the lower speed specified by P01.09 to enable DC braking.

Method 3 Set P08.52 to enable magnetic flux braking to accelerate the motor's deceleration tracking process.

Method 4 Add braking resistors.

Method 5 Set the S-curve deceleration method.

| Function code | Name | Default | Setting range | Description |
|---------------|-----------------------------|---------|---------------|---|
| P01.10 | Demagnetization time | 0.00s | 0.00–30.00s | The VFD blocks the output before starting DC braking for stop. The VFD starts DC braking after this time so as to prevent overcurrent caused by DC braking at high speed. |
| P01.11 | DC braking current for stop | 0.0% | 0.0–100.0% | Percentage of the VFD rated output current. Stronger current indicates greater DC braking effect. |
| P01.12 | DC braking time for stop | 0.00s | 0.0–50.0s | DC braking duration. If the time is 0, DC braking is invalid, and the VFD decelerates to stop within the specified time. |
| P01.15 | Stop speed | 0.50Hz | 0.00Hz–P00.03 | - |
| P01.16 | Stop speed detection mode | 0 | 0–1 | 0: Detect by the set speed (unique in space voltage vector control mode) 1: Detect according to speed feedback |

| Function code | Name | Default | Setting range | Description |
|---------------|---------------------------|---------|---------------|-------------|
| P01.17 | Stop speed detection time | 0.50s | 0.00–100.00s | - |
| P01.24 | Stop speed delay | 0.0s | 0.0–600.0s | - |

6.7.3 Power-off restart

For all command running channels, if P01.21=1, the VFD memorizes the running status at power off. If the VFD is running before power-off, the VFD automatically runs with a wait time specified by P01.22 at the next power-on when start conditions are met.

When terminals are used as the command running channel, you need to set P01.18 to 1. The following figure shows the wait time for restart after power-off.

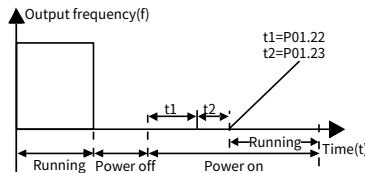

The following figure shows the logic diagram for restart after power-off.

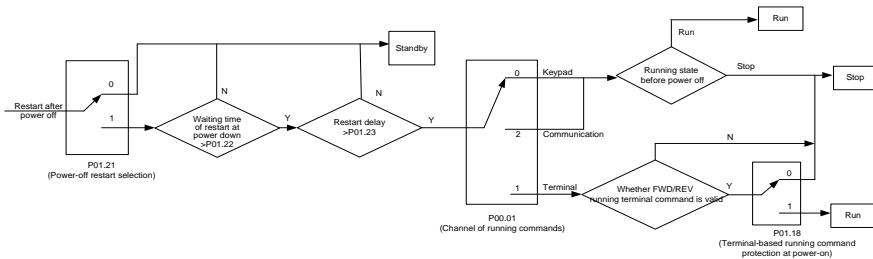

| Function code | Name | Default | Setting range | Description |
|---------------|--------------------------------|---------|---------------|---|
| P01.21 | Power-off restart selection | 0 | 0–1 | 0: Disable 1: Enable |
| P01.22 | Wait time for power-on restart | 1.0s | 0.0–3600.0s | It is valid when P01.21=1. The function code indicates the wait time before the automatic running of the VFD that is re-powered on. |

| Function code | Name | Default | Setting range | Description |
|---------------|---|---------|---------------|--|
| P01.23 | Start delay time | 0.0s | 0.0–600.0s | After a VFD running command is given, the VFD restarts running output with the delay defined by P01.23 from the standby state, to implement brake release. |
| P01.18 | Terminal-based running command protection at power-on | 0 | 0–1 | 0: Invalid at power-on 1: Valid at power-on Note: Exercise caution before using this function. Otherwise, serious consequences may result. |

Terminal-based running command is invalid at power-on: P01.18 = 0

Though the command running terminal is considered as valid during power-on, the VFD does not run and it keeps the protection state until the terminal is disabled and then enabled.

Terminal-based running command is valid at power-on: P01.18=1

If the command running terminal is considered as valid during power-on, the VFD is started automatically after the initialization.

6.8 Control performance regulation

6.8.1 Space vector control performance optimization

The following uses space vector control performance optimization for motor 1 as an example. For details about related function codes, see Group P04—V/F control of motor 1. For the commissioning of space vector control performance optimization for motor 2, refer to that is for motor 1. For details about related function codes, see Group P36—V/F control of motor 2.

6.8.1.1 V/F curve setting

The VFD provides multiple V/F curve modes to meet different requirements. You can select V/F curves or set V/F curves as required.

For the load featuring constant torque, such as conveyor belt which runs in straight line, as the whole running process requires constant torque, it is recommended to adopt the straight line V/F curve.

For the load featuring decreasing torque, such as fan and water pumps, as there is a power (square or cube) relationship between its actual torque and speed, it is recommended to adopt the V/F curve corresponding to the power of 1.3, 1.7 or 2.0.

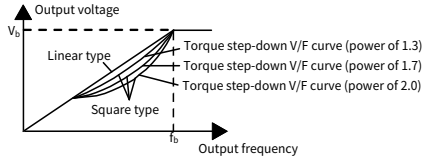

Note: In the figure, V_0 indicates the motor rated voltage and f_b indicates the motor rated frequency.

| Function code | Name | Default | Setting range | Description |
|---------------|------------------------------|---------|---------------|--|
| P04.00 | V/F curve setting of motor 1 | 0 | 0-5 | 0: Straight-line V/F curve, applicable to constant torque loads 1: Multi-point V/F curve 2: Torque-down V/F curve (power of 1.3) 3: Torque-down V/F curve (power of 1.7) 4: Torque-down V/F curve (power of 2.0) 5: Customized V/F (V/F separation); in this mode, V can be separated from F and F can be adjusted through the frequency setting channel set by P00.06 or the voltage setting channel set by P04.13 to change the characteristics of the curve. |

The VFD also provides multi-point V/F curves. You can change the VFD output V/F curves by setting the voltage and frequency of the three points in the middle. The complete curve consists of five points starting from (0Hz, 0V) and ending at (motor fundamental frequency, motor rated voltage). During setting, follow the rule: $0 \leq f_1 \leq f_2 \leq f_3 \leq$ Motor fundamental frequency, and $0 \leq V_1 \leq V_2 \leq V_3 \leq$ Motor rated voltage. Too high voltage for low frequency will cause motor overheat or damage and cause VFD overcurrent stall or overcurrent protection. When P04.00 is set to 1 (multi-dot V/F curve), you can set the V/F curve through P04.03-P04.08.

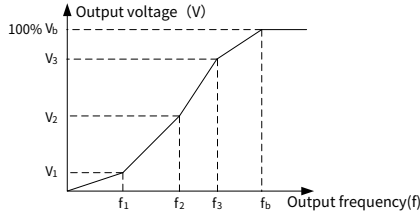

| Function code | Name | Default | Setting range | Description |
|---------------|----------------------------------|---------|--|--|
| P04.03 | V/F frequency point 1 of motor 1 | 0.00Hz | 0.00Hz–P04.05 | - |
| P04.04 | V/F voltage point 1 of motor 1 | 0.0% | 0.0%–110.0% | 100% corresponds to the motor 1 rated voltage. |
| P04.05 | V/F frequency point 2 of motor 1 | 0.00Hz | P04.03–P04.07 | - |
| P04.06 | V/F voltage point 2 of motor 1 | 0.0% | 0.0%–110.0% | 100% corresponds to the motor 1 rated voltage. |
| P04.07 | V/F frequency point 3 of motor 1 | 0.00Hz | P04.05–P02.02 (Hz, P02.00=0 Rated frequency of AM 1) or P04.05–P02.16 (Hz, P02.00=1 Rated frequency of SM 1) | - |
| P04.08 | V/F voltage point 3 of motor 1 | 0.0% | 0.0%–110.0% | 100% corresponds to the motor 1 rated voltage. |

6.8.1.2 Torque boost

Boost compensation to output voltage can effectively improve the low-speed torque performance in the V/F control. The cut-off frequency of manual torque boost is a percentage of the rated motor frequency f_b . Torque boost can improve the low-frequency torque characteristics in the V/F control.

You need to select torque boost based on the load. The load is proportional to the boost,

but the boost cannot be too large. If the torque boost is too large, the motor will run at over-excitation, which may cause increased output current and motor overheating, thus decreasing the efficiency. The default torque boost is 0.0%, which indicates automatic torque boost so that the VFD can regulate the torque boost based on the actual load.

Set P04.01 to determine the torque boost of motor 1. Set P04.02 to determine the torque boost cut-off frequency of motor 1. Below this frequency threshold, torque boost is valid; exceeding this threshold will invalidate torque boost. See the following figure.

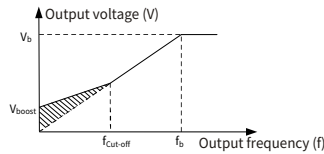

| Function code | Name | Default | Setting range | Description |
|---------------|---------------------------------|---------|---------------|---|
| P04.01 | Torque boost of motor 1 | 0.0% | 0.0%–10.0% | 0.0% (automatic torque boost); 0.1%–10.0% (manual torque boost) Note: V_b indicates the max. output voltage. |
| P04.02 | Torque boost cut-off of motor 1 | 20.0% | 0.0%–50.0% | The cut-off frequency of manual torque boost is a percentage of the rated motor frequency f_b . Torque boost can improve the low-frequency torque characteristics in the V/F control. |

6.8.1.3 V/F slip compensation gain

The V/F control is an open-loop mode, while a sudden motor load change will cause motor rotation speed fluctuation. In cases where strict speed requirements must be met, you can set the slip compensation gain through P04.09 to change the VFD internal output adjustment method and therefore compensate for the speed change caused by load fluctuation, improving the motor mechanical rigidity.

The formula used to calculate the motor rated slip frequency is as follows: $\Delta f = f_b - n \cdot p / 60$

Of which, f_b indicates the rated frequency of motor 1, corresponding to function code P02.02; n indicates the rated rotation speed of motor 1, corresponding to function code P02.03; p indicates the number of motor pole pairs. 100.0% corresponds to the rated slip frequency Δf of motor 1.

| Function code | Name | Default | Setting range | Description |
|---------------|---------------------------------------|---------|---------------|---|
| P04.09 | V/F slip compensation gain of motor 1 | 100.0% | 0.0–200.0% | For P04.09, 100.0% corresponds to the rated slip frequency Δf of motor 1. |

6.8.1.4 Oscillation control

In large-power driving scenarios, using the space voltage vector control mode will cause motor oscillation, which can be eliminated by setting P04.10 and P04.11, while the oscillation control threshold of motor 1 is specified by P04.12.

| Function code | Name | Default | Setting range | Description |
|---------------|--|---------|---------------|---|
| P04.10 | Low-frequency oscillation control factor of motor 1 | 10 | 0–100 | Setting a greater value indicates better control effect. However, if the value is too large, the VFD output current may be too large. |
| P04.11 | High-frequency oscillation control factor of motor 1 | 10 | 0–100 | |
| P04.12 | Oscillation control threshold of motor 1 | 30.00Hz | 0.00Hz–P00.03 | |

6.8.1.5 V/F flux weakening performance optimization

When the AM needs to run with flux weakened, set P04.19 in the V/F control mode to increase the output voltage and maximize the bus voltage utilization, improving the motor acceleration performance.

| Function code | Name | Default | Setting range | Description |
|---------------|--|---------|---------------|-------------|
| P04.19 | V/F constant power zone weakening coefficient of motor 1 | 1.00 | 1.00–1.30 | - |

6.8.1.6 AM IF control

Generally, the IF control mode is valid for AMs. It can be used for SMs only when the frequency is extremely low. IF control is implemented by performing closed-loop control on the total output current of the VFD. The output voltage adapts to the current reference, and open-loop control is separately performed over the frequency of the voltage and current. Take AM 1 for example. Set P04.26 to 1 to enable the IF mode for AM 1. You can set related parameters when the IF mode is enabled.

| Function code | Name | Default | Setting range | Description |
|---------------|---|---------|---------------|---|
| P04.26 | Enabling IF mode for AM 1 | 0 | 0–1 | 0: Invalid 1: Enable |
| P04.27 | Current setting in IF mode for AM 1 | 120.0% | 0.0–200.0 | When IF control is adopted for AM 1, the function code is used to set the output current. The value is a percentage of the motor rated current. |
| P04.28 | Proportional coefficient in IF mode for AM 1 | 350 | 0–5000 | When IF control is adopted for AM 1, the function code is used to set the proportional coefficient of the output current closed-loop control. |
| P04.29 | Integral coefficient in IF mode for AM 1 | 150 | 0–5000 | When IF control is adopted for AM 1, the function code is used to set the integral coefficient of the output current closed-loop control. |
| P04.30 | Frequency threshold for switching off IF mode for motor 1 | 10.00Hz | 0.00Hz–P04.31 | - |
| P04.31 | End frequency point for switching off IF mode for motor 1 | 25.00Hz | P04.30–P00.03 | - |

6.8.1.7 Energy-saving run for AM V/F

During AM actual running, the VFD can search for the max. efficiency point so as for the

AM to keep running in the most efficient state to save energy. This function is generally used in light load or no-load cases. Set P04.32 to specify whether to act in energy-saving run.

| Function code | Name | Default | Setting range | Description |
|---------------|---|---------|---------------|--|
| P04.32 | V/F control energy-saving mode selection for AM 1 | 0 | 0–3 | 0: Disable (Energy saving is invalid) 1: Max. efficiency 2: Optimal power factor 3: Max. ratio of torque to current In light-load state, the motor can adjust the output voltage automatically to achieve energy saving. This function is not applicable to the cases where sudden load changes often occur. |
| P04.33 | V/F control energy-saving optimization coefficient for AM 1 | 100.0% | 25.0–400.0% | - |

6.8.1.8 Reactive current regulation in SM V/F control

When the SM V/F control mode is enabled, you can set P04.22 to specify the frequency threshold for the switching between pull-in current 1 and pull-in current 2. When the output frequency is less than P04.22, the motor reactive current is specified by P04.20; when the output frequency is greater than P04.22, the motor reactive current is specified by P04.21.

| Function code | Name | Default | Setting range | Description |
|---------------|--|---------|----------------|--|
| P04.20 | Pull-in current 1 in V/F control of SM 1 | 30.0% | -100.0%–100.0% | 100% corresponds to the motor rated current. |
| P04.21 | Pull-in current 2 in V/F control of SM 1 | 10.0% | -100.0%–100.0% | 100% corresponds to the motor rated current. |
| P04.22 | V/F control pull-in current frequency switching point for SM 1 | 20.0% | 0.0%–200.0% | 100% corresponds to the motor rated frequency. |

| Function code | Name | Default | Setting range | Description |
|---------------|--|---------|---------------|--|
| P04.23 | V/F control reactive current closed-loop proportional coefficient for SM 1 | 50 | 0–500 | When the SM VF control mode is enabled, the function code is used to set the proportional coefficient of reactive current closed-loop control. |
| P04.24 | V/F control reactive current closed-loop integral time for SM 1 | 30 | 0–300 | When the SM VF control mode is enabled, the function code is used to set the integral coefficient of reactive current closed-loop control. |
| P04.25 | V/F control reactive closed-loop output limit for SM 1 | 8000 | 0–16000 | - |

6.8.2 Vector control performance optimization

The following uses vector control performance optimization for motor 1 as an example. For details about related function codes, see Group P03—Vector control of motor 1. The space vector control performance optimization for motor 2 is similar to that is for motor 1. For details about related function codes, see Group P35—Vector control of motor 2.

6.8.2.1 Torque upper limit

Speed control and torque control in the vector control mode are restricted by torque upper limits. When you set P03.18 (Setting source of electromotive torque upper limit) to keypad, the torque upper limit is specified by P03.20. When you set P03.19 (Setting source of braking torque upper limit) to keypad, the torque upper limit is specified by P03.21.

| Function code | Name | Default | Setting range | Description |
|---------------|--|---------|---------------|---|
| P03.18 | Setting source of electromotive torque upper limit for motor 1 | 0 | 0–15 | 0: Set by P03.20 (selected by P03.18) 0: Set by P03.21 (selected by P03.19) |
| P03.19 | Setting source of braking torque upper limit for motor 1 | 0 | 0–15 | 1: AI1 2: AI2 3: AI3 5: High-speed pulse HD11 10: Modbus/Modbus TCP |

| Function code | Name | Default | Setting range | Description |
|---------------|---|---------|---------------|---|
| | | | | communication 12: Ethernet communication 14: EtherCAT/PROFINET/EtherNet IP communication Others: Reserved Note: 100% corresponds to the motor rated current. |
| P03.20 | Electromotive torque upper limit set through keypad for motor 1 | 180.0% | 0.0–300.0% | Used to set relative values of torque limits. |
| P03.21 | Braking torque upper limit set through keypad for motor 1 | 180.0% | 0.0–300.0% | The value is relative to the motor rated current. |

6.8.2.2 Frequency upper limit settings in torque control

In torque control, the VFD outputs torque according to the set torque command. When the set torque is greater than the load torque, the VFD output frequency increases to the frequency upper limit; when the set torque is less than the load torque, the VFD output frequency decreases to the frequency lower limit; when the VFD output frequency is restricted, the output torque will no longer be the same as the set torque. When you set P03.14 to set the setting source of forward rotation upper-limit frequency in torque control, the torque limit is specified by P03.16. When you set P03.15 to set the setting source of reverse rotation upper-limit frequency in torque control, the torque limit is specified by P03.17.

| Function code | Name | Default | Setting range | Description |
|---------------|---|---------|---------------|--|
| P03.14 | Forward rotation upper-limit frequency source in torque control for motor 1 | 0 | 0–15 | 0: Set by P03.16 (selected by P03.14) 0: Set by P03.17 (selected by P03.15) 1: AI1 |
| P03.15 | Reverse rotation upper-limit frequency source in torque control for | 0 | 0–15 | 2: AI2 3: AI3 5: High-speed pulse HDI1 8: Multi-step speed running |

| Function code | Name | Default | Setting range | Description |
|---------------|--|---------|---------------------------------------|---|
| | motor 1 | | | 10: Modbus/Modbus TCP communication 12: Ethernet communication 14: EtherCAT/PROFINET/EtherNet IP communication Others: Reserved Note: For setting 1 and above, 100% corresponds to the max. frequency. |
| P03.16 | Forward rotation upper-limit frequency in torque control for motor 1 | 50.00Hz | 0.00Hz–P00.03 (Max. output frequency) | Used to specify the frequency upper limits in torque control. 100% corresponds to the max. frequency. P03.16 specifies the value when P03.14=1; while P03.17 specifies the value when P03.15=1. |
| P03.17 | Reverse rotation upper-limit frequency in torque control for motor 1 | | | |

6.8.2.3 Speed loop

The speed loop dynamic response characteristics in vector control can be adjusted by setting the proportional coefficient and integral time of speed regulator.

The dynamic response of speed regulator can be accelerated by increasing the proportional gain or decreasing the integral time. However, too quick dynamic response of speed regulator can cause oscillations.

Recommended adjustment method: If the default settings can not meet the requirements, adjust the settings slightly. First, increase the proportional gain to ensure that the system does not oscillate; and then reduce the integration time, so that the system responds fast with small overshoot.

Improper PI parameter settings will cause large speed overshoot.

The switchover between the low-point frequency for switching and the high-point frequency for switching indicates the linear switchover between two groups of PI parameters. See the following figure.

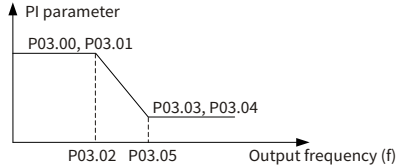

| Function code | Name | Default | Setting range | Description |
|---------------|---|---------|---------------|--|
| P03.00 | Speed-loop proportional gain 1 of motor 1 | 20.0 | 0.0–200.0 | Speed regulator PI parameters are divided into the low-speed group and high-speed group. |
| P03.01 | Speed-loop integral time 1 of motor 1 | 0.200s | 0.000–10.000s | When the running frequency is less than P03.02, the speed regulator PI parameters are P03.00 and P03.01. |
| P03.02 | Motor 1 switching low-point frequency | 5.00Hz | 0.00Hz–P03.05 | When the running frequency is greater than P03.05 (High-point frequency for switching), the speed regulator PI parameters are P03.03 and P03.04. |
| P03.03 | Speed-loop proportional gain 2 of motor 1 | 20.0 | 0.0–200.0 | |
| P03.04 | Speed-loop integral time 2 of motor 1 | 0.200s | 0.000–10.000s | - |
| P03.05 | Switching high-point frequency of motor 1 | 10.00Hz | P03.02–P00.03 | - |
| P03.06 | Speed-loop output filter of motor 1 | 0 | 0–8 | 0–8 (corresponding to 0–2 ⁸ /10ms) |
| P03.36 | Speed-loop differential gain of motor 1 | 0.00s | 0.00–10.00s | - |

6.8.2.4 Current loop

Generally, there is no need to adjust it. If the current waveform is not sinusoidal, the current loop band width can be reduced.

| Function code | Name | Default | Setting range | Description |
|---------------|------------------------------------|---------|---------------|-------------|
| P03.54 | Current-loop band width of motor 1 | 400 | 0–2000 | - |

6.8.2.5 Vector control flux weakening performance optimization

When running at a speed higher than the rated speed, the AM enters the flux weakening state. You can set P03.22 to change the flux-weakening curvature. A great flux-weakening control coefficient indicates a steep curve. The weakening coefficient in constant power zone is used in AM flux-weakening control, while the flux-weakening proportional gain and flux-weakening integral gain are specified by P03.26 and P03.33. The max. VFD output voltage is specified by P03.24.

If pre-exciting is performed for the motor when the VFD starts up, a magnetic field is built up inside the motor to improve the torque performance during the start process. The pre-exciting time is specified by P03.25.

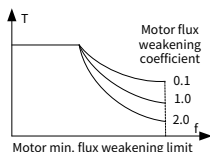

| Function code | Name | Default | Setting range | Description |
|---------------|---|---------|---------------|--|
| P03.22 | Weakening coefficient in constant power zone for motor 1 | 100.0% | 0.0–200.0% | A field weakening curve is selected through the field weakening coefficient. |
| P03.23 | Lowest weakening point in constant power zone for motor 1 | 5% | 5%–100.0% | the lowest weakening point in constant power zone is specified by P03.23. |
| P03.24 | Max. voltage limit on motor 1 | 100.0% | 0.0–120.0% | Used to set the max. VFD output voltage, which is a percentage of the motor rated voltage. Set the |

| Function code | Name | Default | Setting range | Description |
|---------------|---|---------|---------------|---|
| | | | | value according to onsite conditions. |
| P03.25 | Pre-exciting time of motor 1 | 0.300s | 0.000–10.000s | Pre-exciting is performed for the motor when the VFD starts up. A magnetic field is built up inside the motor to improve the torque performance during the start process. Note: Pre-excitation can improve the start-up capability of AM with loads. For an AM, set 0 to disable the pre-excitation process. For an SM, if P13.01 is set to an enabling option, the pre-excitation process is directly skipped. |
| P03.26 | Flux-weakening proportional gain of motor 1 | 1000 | 0–8000 | - |
| P03.33 | Flux-weakening integral gain of motor 1 | 100.0% | 0.0–300.0% | - |

6.8.2.6 SM start control optimization

In the open-loop control mode, you can select a start control method by setting P13.01.

| Function code | Name | Default | Setting range | Description |
|---------------|-------------------------------|---------|---------------|---|
| P13.01 | Initial pole detection method | 2 | 0–2 | 0: Do not detect 1: High-frequency superposition 2: Pulse superposition |

No detection: P13.01=0

The VFD startup command given is a direct startup command. In this mode, set P13.02 to a great value to increase the starting torque, which causes a start reversal phenomenon with an average load carrying capacity.

High-frequency current injection: P13.01=1

If a VFD startup command is given, the VFD autotunes the initial pole angle by means of

high-frequency current injection and then automatically starts up after the autotuning. When P13.02 is valid and the initial pole angle based direction setting is accurate, the reverse rotation problem can be weakened or eliminated, but also the load carrying capacity can be improved.

Pulse superimposition: P13.01=2

This method is similar to that when P13.01=1. The difference is that the initial pole angle autotuning method is different. This method has higher identification accuracy with shorter time but sharper noise, but you can adjust the pulse current value by setting P13.06.

| Function code | Name | Default | Setting range | Description |
|---------------|-------------------------------------|---------|----------------|--|
| P13.02 | Pull-in current 1 | 30.0% | -100.0%~100.0% | Pull-in current is the pole position orientation current; pull-in current 1 is valid within the lower limit of pull-in current switch-over frequency threshold. If you need to increase the start torque, increase the value of this function parameter properly. 100% corresponds to the motor rated current. |
| P13.03 | Pull-in current 2 | 0.0% | -100.0%~100.0% | Specifies the pole position orientation current. It is valid within the upper limit of pull-in current switching frequency threshold. You do not need to change the value in most cases. 100% corresponds to the motor rated current. |
| P13.04 | Pull-in current switching frequency | 20.0% | 0.0~200.0% | 100% corresponds to the motor rated frequency. |
| P13.06 | Pulse current setting | 80.0% | 0.0~300.0% | Used to set the pulse current threshold when the initial magnetic pole position is detected in the pulse mode. 100% corresponds to the motor rated current. |

6.9 Input and output

6.9.1 Digital input and output

6.9.1.1 Digital input

The VFD carries four programmable digital input terminals and one HDI input terminal. The functions of all the digital input terminals can be programmed through function codes. The HDI input terminal can be set to act as a high-speed pulse input terminal or common digital input terminal by setting P05.00; if it is set to act as a high-speed pulse input terminal, you can also set HDI1 high-speed pulse input to serve as the frequency reference input.

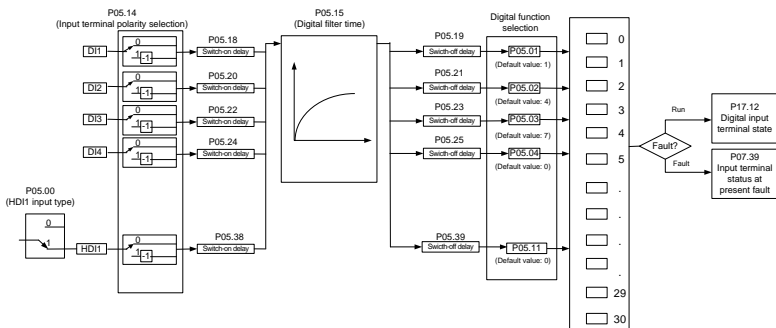

Note: Two different multifunction input terminals cannot be configured with a same function.

P05.01–P05.08, and P05.11 are used to set the functions of multifunction digital input terminals. Terminal functions are set as follows.

| Setting | Function | Description |
|---------|--|--|
| 0 | No function | The VFD does not act even if there is signal input. Set unused terminals to "no function" to avoid misaction. |
| 1 | Run forward (FWD) | External terminals are used to control the forward/reverse running of the VFD. |
| 2 | Run reversely (REV) | |
| 3 | Three-wire running control (DI _{in}) | The terminal is used to determine the three-wire running control of the VFD. See P05.17 for details. |
| 4 | Forward jogging | For details about frequency of jogging running and ACC/DEC time of jogging running, see the description for P08.08–P08.10. |
| 5 | Jog reversely | |
| 6 | Coast to stop | The VFD blocks output, and the stop process of motor is uncontrolled by the VFD. This mode is applied in the |

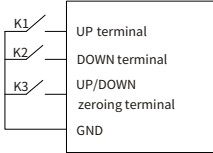
| Setting | Function | Description |
|---------|--|---|
| | | scenarios with large-inertia loads and without stop time requirements. Its definition is the same as the coasting to stop specified by P01.08, and it is mainly used in remote control. |
| 7 | Fault reset | External fault reset function, same as the reset function of the STOP/RST key on the keypad. You can use this function to reset faults remotely. |
| 8 | Pause running | The VFD decelerates to stop, however, all the run parameters are in memory state, such as PLC parameter, wobbling frequency, and PID parameter. After this signal disappears, the VFD will revert to the state before stop. |
| 9 | External fault input | When external fault signal is transmitted to the VFD, the VFD releases fault alarm and stops. |
| 10 | Increase frequency setting (UP) | Used to change the frequency increase/decrease command when the frequency is given by external terminals. |
| 11 | Decrease frequency setting (DOWN) |  |
| 12 | Clear the frequency increase/decrease setting | |
| 13 | Switch between A setting and B setting | The function is used to switch between the frequency setting channels. |
| 14 | Switch between combination setting and A setting | A frequency reference channel and B frequency reference channel can be switched by function 13; the combination channel set by P00.09 and the A frequency reference channel can be switched by function 14; the combination channel set by P00.09 and the B frequency reference channel can be switched by function 15. |
| 15 | Switch between combination setting and B setting | |
| 16 | Multi-step speed terminal 1 | A total of 16-step speeds can be set by combining digital states of these four terminals. Note: Multi-step speed 1 is the LSB, and multi-step speed 4 is the MSB. |
| 17 | Multi-step speed terminal 2 | |

| Setting | Function | Description | | | |
|---------|--|--|--------------------|--------------------|--------------------|
| | | Multi-step speed 4 | Multi-step speed 3 | Multi-step speed 2 | Multi-step speed 1 |
| 18 | Multi-step speed terminal 3 | Bit3 | Bit2 | Bit1 | Bit0 |
| 19 | Multi-step speed terminal 4 | | | | |
| 20 | Pause multi-step speed running | The multi-step speed selection function can be screened to keep the set value in the present state. | | | |
| 21 | ACC/DEC time selection 1 | The status of the two terminals can be combined to select four groups of ACC/DEC time. | | | |
| 22 | ACC/DEC time selection 2 | Terminal 1 | Terminal 2 | ACC/DEC time | Parameter |
| | | OFF | OFF | ACC/DEC time 1 | P00.11/P00.12 |
| | | ON | OFF | ACC/DEC time 2 | P08.00/P08.01 |
| | | OFF | ON | ACC/DEC time 3 | P08.02/P08.03 |
| | | ON | ON | ACC/DEC time 4 | P08.04/P08.05 |
| 23 | Simple PLC stop reset | Used to clear the previous PLC state memory information and restart the simple PLC process. | | | |
| 24 | Pause simple PLC | Used to pause the simple PLC. When the function is revoked, the simple PLC resumes the running. | | | |
| 25 | Pause PID control | PID is ineffective temporarily, and the VFD maintains current frequency output. | | | |
| 26 | Pause wobbling frequency (stop at present frequency) | The VFD pauses at current output. After this function is canceled, it continues wobbling-frequency operation at current frequency. | | | |
| 27 | Reset wobbling frequency (back to center frequency) | The set frequency of VFD reverts to center frequency. | | | |
| 28 | Reset the counter | The counter is cleared. | | | |
| 29 | Switch between speed control and torque control | The VFD switches from torque control mode to speed control mode, or vice versa. | | | |
| 30 | Disable ACC/DEC | Used to ensure the VFD is not impacted by external signals (except for stop command), and maintains the present output frequency. | | | |
| 31 | Trigger the counter | Used to enable the counter to count pulses. | | | |
| 32 | Motor switching terminal | When P08.31 (Motor switchover selection) is set to terminal, if the terminal is invalid, motor 1 is selected; if the terminal is valid, motor 2 is selected. | | | |

| Setting | Function | Description |
|---------|---|--|
| 33 | Clear the frequency increase/decrease setting temporarily | When the terminal is closed, the frequency value set by the UP/DOWN key can be cleared and restored to the frequency given by frequency command channel; when the terminal is opened, it is changed to the frequency value after frequency increase/decrease setting. |
| 34 | DC braking | The VFD starts DC brake immediately after the command becomes valid. |
| 35 | Clear the frequency increase/decrease setting temporarily | When the terminal is closed, the frequency value set by <u>UP/DOWN</u> can be cleared to restore the reference frequency to the frequency given by frequency command channel; when the terminal is opened, it restores to the frequency value after frequency increase/decrease setting. |
| 36 | Switch the running command channel to keypad | When the function is enabled, the running command channel is switched to keypad. When the function is disabled, the running command channel is restored to the previous setting. |
| 37 | Switch the running command channel to terminal | When the function is enabled, the running command channel is switched to terminal. When the function is disabled, the running command channel is restored to the previous setting. |
| 38 | Switch the running command channel to communication | When the function is enabled, the running command channel is switched to communication. When the function is disabled, the running command channel is restored to the previous setting. |
| 39 | Pre-exciting command | When the function is enabled, motor pre-exciting is started until the function becomes invalid. |
| 40 | Clear power consumption quantity | After this command becomes valid, the power consumption quantity of the VFD will be zeroed out. |
| 41 | Keep power consumption quantity | When the function is enabled, the present operation of the VFD does not impact the power consumption quantity. |
| 42 | Switch the setting source of braking torque upper limit to keypad | The torque upper limit is set through the keypad when the command is valid. |
| 56 | Emergency stop | When the function is enabled, the motor decelerates to stop in emergency manner according to the time specified by P01.26. |

| Setting | Function | Description |
|---------|-----------------------------------|--|
| 57 | Motor overtemperature fault input | When there is motor overtemperature fault input, the motor stops due to the fault. |
| 61 | Switch PID polarities | Used to switch the output polarity of PID. It is used together with P09.03. |

Related parameters are listed in the following.

| Function code | Name | Default | Setting range | Description |
|---------------|---------------------------|---------|---------------|---|
| P05.00 | HDI input type | 0 | 0–1 | 0: HDI1 is high-speed pulse input 1: HDI1 is digital input |
| P05.01 | Function of DI1 | 1 | 0–95 | For details, see the preceding table. DI1–DI4 and HDIA are the terminals on the control board, while DI5–DI8 are achieved through the virtual terminal functions set by P05.16. |
| P05.02 | Function of DI2 | 4 | | |
| P05.03 | Function of DI3 | 7 | | |
| P05.04 | Function of DI4 | 0 | | |
| P05.05 | Function of DI5 | 0 | | |
| P05.06 | Function of DI6 | 0 | | |
| P05.07 | Function of DI7 | 0 | | |
| P05.08 | Function of DI8 | 0 | | |
| P05.11 | Function of HDI1 | 0 | | |
| P05.14 | Input terminal polarity | 0x000 | 0x000–0x7FF | Used to set the input terminal polarity. When a bit is 0, the input terminal is positive. When a bit is 1, the input terminal is negative. Note: For Modbus/Modbus TCP communication, the virtual terminal address is 0x200A. For other communication protocols, see the PZD receiving function code options. |
| P05.15 | Digital input filter time | 0.010 | 0.000–1.000s | Used to specify the sampling filter time of the DI1–DI8, and HDI1 terminals. In strong interference cases, increase the value to avoid maloperation. |

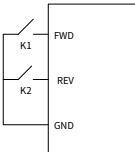
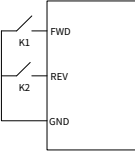
| Function code | Name | Default | Setting range | Description | | | | | | | | | | | | | | | | | | | | | | | | | | | | | | |
|---------------|--------------------------|-----------------|---------------|---|-----|-----|-----------------|-----|-----|------|----|-----|-----------------|-----|----|-----------------|----|----|------|-----|-----|-----------------|-----|-----|------|----|-----|-----------------|-----|----|------|----|----|-----------------|
| P05.16 | Virtual terminal setting | 0x000 | 0x000-0x7FF | Bit 0: DI1 Bit 1: DI2 Bit 2: DI3 Bit 3: DI4 Bit 4: DI5 Bit 5: DI6 Bit 6: DI7 Bit 7: DI8 Bit 8: Reserved Bit 9: Reserved Bit 10: HDI1 | | | | | | | | | | | | | | | | | | | | | | | | | | | | | | |
| P05.17 | Terminal control mode | 0 | 0-3 | P05.17 specifies the running mode in terminal control. | | | | | | | | | | | | | | | | | | | | | | | | | | | | | | |
| P05.18 | DI1 switch-on delay | 0.000s | 0.000-50.000s | <p>0: Two-wire control 1, the enabling consistent with the direction. This mode is widely used. The defined FWD/REV terminal command determines the motor rotation direction.</p>  <table border="1" data-bbox="834 829 957 981"> <tr> <td>FWD</td> <td>REV</td> <td>Running command</td> </tr> <tr> <td>OFF</td> <td>OFF</td> <td>Stop</td> </tr> <tr> <td>ON</td> <td>OFF</td> <td>Forward running</td> </tr> <tr> <td>OFF</td> <td>ON</td> <td>Reverse running</td> </tr> <tr> <td>ON</td> <td>ON</td> <td>Hold</td> </tr> </table> <p>1: Two-wire control 2, the enabling separated from the direction. In this mode, FWD is the enabling terminal. The direction depends on the defined REV state.</p>  <table border="1" data-bbox="834 1149 957 1300"> <tr> <td>FWD</td> <td>REV</td> <td>Running command</td> </tr> <tr> <td>OFF</td> <td>OFF</td> <td>Stop</td> </tr> <tr> <td>ON</td> <td>OFF</td> <td>Forward running</td> </tr> <tr> <td>OFF</td> <td>ON</td> <td>Stop</td> </tr> <tr> <td>ON</td> <td>ON</td> <td>Reverse running</td> </tr> </table> <p>2: Three-wire control 1. This mode defines DI_{in} as the enabling terminal, and the running command is generated by FWD,</p> | FWD | REV | Running command | OFF | OFF | Stop | ON | OFF | Forward running | OFF | ON | Reverse running | ON | ON | Hold | FWD | REV | Running command | OFF | OFF | Stop | ON | OFF | Forward running | OFF | ON | Stop | ON | ON | Reverse running |
| FWD | REV | Running command | | | | | | | | | | | | | | | | | | | | | | | | | | | | | | | | |
| OFF | OFF | Stop | | | | | | | | | | | | | | | | | | | | | | | | | | | | | | | | |
| ON | OFF | Forward running | | | | | | | | | | | | | | | | | | | | | | | | | | | | | | | | |
| OFF | ON | Reverse running | | | | | | | | | | | | | | | | | | | | | | | | | | | | | | | | |
| ON | ON | Hold | | | | | | | | | | | | | | | | | | | | | | | | | | | | | | | | |
| FWD | REV | Running command | | | | | | | | | | | | | | | | | | | | | | | | | | | | | | | | |
| OFF | OFF | Stop | | | | | | | | | | | | | | | | | | | | | | | | | | | | | | | | |
| ON | OFF | Forward running | | | | | | | | | | | | | | | | | | | | | | | | | | | | | | | | |
| OFF | ON | Stop | | | | | | | | | | | | | | | | | | | | | | | | | | | | | | | | |
| ON | ON | Reverse running | | | | | | | | | | | | | | | | | | | | | | | | | | | | | | | | |
| P05.19 | DI1 switch-off delay | 0.000s | | | | | | | | | | | | | | | | | | | | | | | | | | | | | | | | |
| P05.20 | DI2 switch-on delay | 0.000s | | | | | | | | | | | | | | | | | | | | | | | | | | | | | | | | |
| P05.21 | DI2 switch-off delay | 0.000s | | | | | | | | | | | | | | | | | | | | | | | | | | | | | | | | |
| P05.22 | DI3 switch-on delay | 0.000s | | | | | | | | | | | | | | | | | | | | | | | | | | | | | | | | |
| P05.23 | DI3 switch-off delay | 0.000s | | | | | | | | | | | | | | | | | | | | | | | | | | | | | | | | |
| P05.24 | DI4 switch-on delay | 0.000s | | | | | | | | | | | | | | | | | | | | | | | | | | | | | | | | |
| P05.25 | DI4 switch-off delay | 0.000s | | | | | | | | | | | | | | | | | | | | | | | | | | | | | | | | |
| P05.26 | DI5 switch-on delay | 0.000s | | | | | | | | | | | | | | | | | | | | | | | | | | | | | | | | |
| P05.27 | DI5 switch-off delay | 0.000s | | | | | | | | | | | | | | | | | | | | | | | | | | | | | | | | |
| P05.28 | DI6 switch-on delay | 0.000s | | | | | | | | | | | | | | | | | | | | | | | | | | | | | | | | |
| P05.29 | DI6 switch-off delay | 0.000s | | | | | | | | | | | | | | | | | | | | | | | | | | | | | | | | |
| P05.30 | DI7 switch-on delay | 0.000s | | | | | | | | | | | | | | | | | | | | | | | | | | | | | | | | |
| P05.31 | DI7 switch-off delay | 0.000s | | | | | | | | | | | | | | | | | | | | | | | | | | | | | | | | |
| P05.32 | DI8 switch-on delay | 0.000s | | | | | | | | | | | | | | | | | | | | | | | | | | | | | | | | |
| P05.33 | DI8 switch-off delay | 0.000s | | | | | | | | | | | | | | | | | | | | | | | | | | | | | | | | |
| P05.38 | HDI1 switch-on delay | 0.000s | | | | | | | | | | | | | | | | | | | | | | | | | | | | | | | | |
| P05.39 | HDI1 switch-off delay | 0.000s | | | | | | | | | | | | | | | | | | | | | | | | | | | | | | | | |

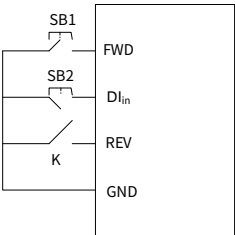
| Function code | Name | Default | Setting range | Description | | | | | | | | | | | | | | | | | | | | | |
|------------------|--------|--------------------|-------------------|--|------------------|-----|--------------------|-------------------|----|--------|---------|---------|---------|---------|----|--------|---------|---------|---------|---------|--------|----|--------------------|--|-----|
| | | | | <p>while the direction is controlled by REV. During running, the DI_{in} terminal needs to be closed, and when terminal FWD generates a rising edge signal, the VFD starts to run in the direction set by the state of terminal REV; the VFD needs to be stopped by disconnecting terminal DI_{in}.</p>  <p>The direction control is as follows during running:</p> <table border="1" data-bbox="676 810 981 1078"> <thead> <tr> <th>DI_{in}</th> <th>REV</th> <th>Previous direction</th> <th>Present direction</th> </tr> </thead> <tbody> <tr> <td rowspan="2">ON</td> <td rowspan="2">OFF→ON</td> <td>FWD run</td> <td>REV run</td> </tr> <tr> <td>REV run</td> <td>FWD run</td> </tr> <tr> <td rowspan="2">ON</td> <td rowspan="2">ON→OFF</td> <td>REV run</td> <td>FWD run</td> </tr> <tr> <td>FWD run</td> <td>REV run</td> </tr> <tr> <td rowspan="2">ON→OFF</td> <td>ON</td> <td colspan="2" rowspan="2">Decelerate to stop</td> </tr> <tr> <td>OFF</td> </tr> </tbody> </table> <p>DI_{in}: Three-wire control; FWD: Forward running; REV: Reverse running</p> <p>3: Three-wire control 2. This mode defines DI_{in} as the enabling terminal, and the running command is generated by FWD or REV, but the direction is controlled by both FWD and REV. During running, the DI_{in} terminal needs to</p> | DI _{in} | REV | Previous direction | Present direction | ON | OFF→ON | FWD run | REV run | REV run | FWD run | ON | ON→OFF | REV run | FWD run | FWD run | REV run | ON→OFF | ON | Decelerate to stop | | OFF |
| DI _{in} | REV | Previous direction | Present direction | | | | | | | | | | | | | | | | | | | | | | |
| ON | OFF→ON | FWD run | REV run | | | | | | | | | | | | | | | | | | | | | | |
| | | REV run | FWD run | | | | | | | | | | | | | | | | | | | | | | |
| ON | ON→OFF | REV run | FWD run | | | | | | | | | | | | | | | | | | | | | | |
| | | FWD run | REV run | | | | | | | | | | | | | | | | | | | | | | |
| ON→OFF | ON | Decelerate to stop | | | | | | | | | | | | | | | | | | | | | | | |
| | OFF | | | | | | | | | | | | | | | | | | | | | | | | |

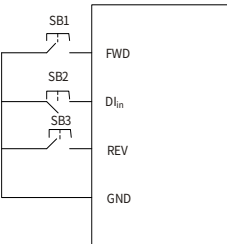
| Function code | Name | Default | Setting range | Description | | | | | | | | | | | | | | | | | | | | |
|------------------|--------|---------|--------------------|--|------------------|-----|-----|-------------------|----|--------|----|---------|-----|---------|----|----|--------|---------|-----|---------|--------|---|---|--------------------|
| | | | | <p>be closed, and terminal FWD or REV generates a rising edge signal to control the running and direction of the VFD; the VFD needs to be stopped by disconnecting terminal DI_{in}.</p>  <table border="1" data-bbox="675 659 981 839"> <thead> <tr> <th>DI_{in}</th> <th>FWD</th> <th>REV</th> <th>Running direction</th> </tr> </thead> <tbody> <tr> <td rowspan="2">ON</td> <td rowspan="2">OFF→ON</td> <td>ON</td> <td>FWD run</td> </tr> <tr> <td>OFF</td> <td>FWD run</td> </tr> <tr> <td rowspan="2">ON</td> <td>ON</td> <td rowspan="2">OFF→ON</td> <td>REV run</td> </tr> <tr> <td>OFF</td> <td>REV run</td> </tr> <tr> <td>ON→OFF</td> <td>-</td> <td>-</td> <td>Decelerate to stop</td> </tr> </tbody> </table> <p>DI_{in}: Three-wire control; FWD: Forward running; REV: Reverse running</p> <p>Note: For two-wire controlled running mode, when the FWD/REV terminal is valid, if the VFD stops due to a stop command given by another source, the VFD does not run again after the stop command disappears even if the control terminal FWD/REV is still valid. To make the VFD run, you need to trigger FWD/REV again, for example, PLC single-cycle stop, fixed-length stop, and valid STOP/RST stop during terminal control. (See P07.04.)</p> <p>The function codes P05.18–P05.38</p> | DI _{in} | FWD | REV | Running direction | ON | OFF→ON | ON | FWD run | OFF | FWD run | ON | ON | OFF→ON | REV run | OFF | REV run | ON→OFF | - | - | Decelerate to stop |
| DI _{in} | FWD | REV | Running direction | | | | | | | | | | | | | | | | | | | | | |
| ON | OFF→ON | ON | FWD run | | | | | | | | | | | | | | | | | | | | | |
| | | OFF | FWD run | | | | | | | | | | | | | | | | | | | | | |
| ON | ON | OFF→ON | REV run | | | | | | | | | | | | | | | | | | | | | |
| | OFF | | REV run | | | | | | | | | | | | | | | | | | | | | |
| ON→OFF | - | - | Decelerate to stop | | | | | | | | | | | | | | | | | | | | | |

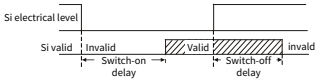
| Function code | Name | Default | Setting range | Description |
|---------------|--|---------|---------------|--|
| | | | | specify the delay time corresponding to the electrical level changes when the programmable input terminals switch on or switch off.  |
| P07.39 | Input terminal status at present fault | 0x0000 | 0x0000-0xFFFF | Displays the present digital input terminal state of the VFD. |
| P17.12 | Digital input terminal state | 0x000 | 0x000-0x1FF | Displays the present digital output terminal state of the VFD. |

6.9.1.2 Digital output

The VFD carries one relay output terminal (RO1) and one high-speed pulse output (HDO1) terminal. All the digital output terminal functions can be specified by function codes.

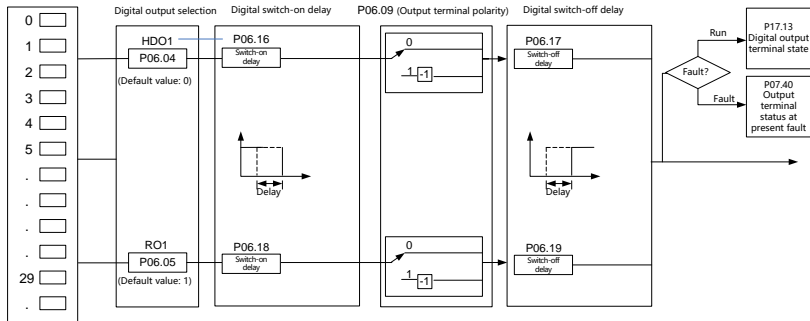

The following table lists the options of function parameters P06.04–P06.05. A same output terminal function can be repeatedly selected.

Note: To use HDO1 to output any of the following functions, you need to select HDO1 as digital output by setting P06.00 to 1.

| Setting | Function | Description |
|---------|-----------------|--|
| 0 | Invalid | The output terminal does not have any function. |
| 1 | Running | The ON signal is output when there is frequency output during running. |
| 2 | Running forward | The ON signal is output when there is frequency output during forward running. |

| Setting | Function | Description |
|---------|--------------------------------|---|
| 3 | Running reversely | The ON signal is output when there is frequency output during reverse running. |
| 4 | Jogging | The ON signal is output when there is frequency output during jogging. |
| 5 | VFD fault | The ON signal is output when a VFD fault occurred. |
| 6 | Frequency level detection FDT1 | When the output frequency exceeds the FDT level detection value, the ON signal is output. When the output frequency drops below the frequency corresponding to (FDT level detection value - FDT lagging detection value), the OFF signal is output. FDT1 and FDT2 level detection values are specified by P08.32 and P08.34, and lagging detection values are specified by P08.33 and P08.35. |
| 7 | Frequency level detection FDT2 | |
| 8 | Frequency reached | When the output frequency falls within the positive and negative tolerance band of the set frequency, the ON signal is output. The positive and negative tolerance band is specified by P08.36. |
| 9 | Running in zero speed | The ON signal is output when the VFD output frequency and reference frequency are both zero. |
| 10 | Upper limit frequency reached | The ON signal is output when the running frequency reaches the upper limit frequency. |
| 11 | Lower limit frequency reached | The ON signal is output when the running frequency reaches the lower limit. |
| 12 | Ready to run | The ON signal is output when main circuit and control circuit powers are established, the protection functions do not act, and the VFD is ready to run. |
| 13 | Pre-exciting | The ON signal is output when the VFD is in pre-exciting. |
| 14 | Overload alarm | The ON signal is output after the alarm time elapsed based on the alarm threshold. The overload alarm is configured by function codes P11.08–P11.10. |
| 15 | Underload alarm | The ON signal is output after the alarm time elapsed based on the alarm threshold. The underload alarm is configured by function codes P11.11– P11.12. |
| 16 | Simple PLC stage completed | When the present state of the simple PLC is completed, it outputs a signal. |
| 17 | Simple PLC cycle completed | When a single cycle of the simple PLC is completed, it outputs a signal. |
| 18 | Set counting value | The ON signal is output when the counting value |

| Setting | Function | Description |
|---------|---|---|
| | reached | reaches the value specified by P08.25 if the counting function is enabled. |
| 19 | Specified counting value reached | The ON signal is output when the counting value reaches the value specified by P08.26 if the counting function is enabled. |
| 20 | External fault is valid | The ON signal is output when the fault is an external fault (E17). |
| 21 | Specified function code value greater than threshold | When the value of the specified function code exceeds the set function code threshold, the ON signal is output. When the value of the specified function code is less than (Function code threshold - Hysteresis width), the OFF signal is output. The specified function code is set by P06.56 (for example, if it is set to 17.00, the specified function code is P17.00). The function code threshold is set by P06.57, and the hysteresis width is set by P06.58. |
| 22 | Running time reached | The ON is output when the single operation time of VFD reaches the time specified by P08.27. |
| 23 | Modbus/ Modbus TCP communication virtual terminal output | A signal is output based on the virtual output terminal of Modbus communication (communication address 0x200B). When the value is 1, the ON signal is output; when the value is 0, the OFF signal is output. |
| 25 | Ethernet communication virtual terminal output | A signal is output based on the value set through communication. When the value is 1, the ON signal is output; when the value is 0, the OFF signal is output. |
| 26 | DC bus voltage established | When the bus voltage is above the inverter undervoltage, the output is valid. |
| 29 | STO action | When an STO fault occurs, the output is valid. |
| 34 | EtherCAT/PROFINET/EtherNet IP communication virtual terminal output | A signal is output based on the value set through communication. When the value is 1, the ON signal is output; when the value is 0, the OFF signal is output. |
| 37 | Any frequency reached | The ON signal is output when the ramp reference frequency is greater than the value specified by P08.37 and this situation lasts the time specified by P08.38. |

Related parameters are listed in the following.

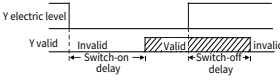
| Function code | Name | Default | Setting range | Description |
|---------------|--|---------|---------------|---|
| P06.00 | HDO1 output type | 0 | 0–1 | 0: High-speed pulse output 1: Digital output |
| P06.04 | HDO1 output | 0 | 0–63 | For details, see the preceding table. |
| P06.05 | RO1 output | 1 | | |
| P06.09 | Output terminal polarity selection | 0x00 | 0x00–0x1F | When a bit is 0, the output terminal is positive. When a bit is 1, the output terminal is negative. Bit 0: Reserved Bit 1: Reserved Bit 2: Reserved Bit 3: HDO1 Bit 4: RO1 |
| P06.16 | HDO1 switch-on delay | 0.000s | 0.000–50.000s | Used to specify the delay time corresponding to the electrical level changes when the programmable output terminals switch on or switch off.  Setting range: 0.000–50.000s |
| P06.17 | HDO1 switch-off delay | | | |
| P06.18 | RO1 switch-on delay | | | |
| P06.19 | RO1 switch-off delay | | | |
| P17.13 | Digital output terminal state | 0x00 | 0x00–0x1F | Displays the present digital output terminal state of the VFD. Bit 0: Reserved Bit 1: Reserved Bit 2: Reserved Bit 3: HDO1 Bit 4: RO1 |
| P07.40 | Output terminal state at present fault | 0x0000 | 0x0000–0xFFFF | Displays the digital output terminal state of the VFD at the present fault. Bit 0: Reserved Bit 1: Reserved Bit 2: Reserved Bit 3: HDO1 Bit 4: RO1 |

6.9.2 Analog input and output terminal functions

6.9.2.1 Analog input

The VFD carries two analog input terminals AI1 and AI2. The input range of AI1 is 0–10V/0–20mA, and whether AI1 uses voltage input or current input can be specified by P05.76. The input range of AI2 is -10–10V. The input source of AI3 is the keypad potentiometer. Each input can be filtered separately, and the corresponding reference curve can be set by adjusting the reference values correspond to the max. value and min. values.

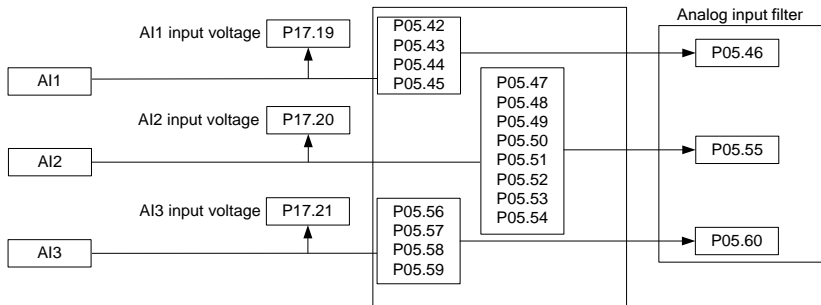

| Function code | Name | Default | Setting range | Description |
|---------------|---|---------|---------------|----------------------------|
| P00.06 | Setting channel of A frequency command | 0 | 0–15 | 1: AI1 2: AI2 3: AI3 |
| P00.07 | Setting channel of B frequency command | 1 | | |
| P03.11 | Torque setting method selection | 0 | 0–15 | |
| P03.14 | Forward rotation upper-limit frequency source in torque control for motor 1 | 0 | 0–15 | |
| P03.15 | Reverse rotation upper-limit frequency source in torque control for motor 1 | 0 | 0–15 | |

| Function code | Name | Default | Setting range | Description |
|---------------|--|---------|---------------|-------------|
| P03.18 | Setting source of electromotive torque upper limit for motor 1 | 0 | 0-15 | |
| P03.19 | Setting source of braking torque upper limit for motor 1 | 0 | 0-15 | |
| P04.13 | Voltage setting channel selection | 0 | 0-15 | |
| P09.00 | PID reference source selection | 0 | 0-15 | |
| P09.02 | PID feedback source selection | 0 | 0-15 | |
| P05.42 | AI1 lower limit | 0.00V | 0.00V-P05.44 | |
| P05.43 | Corresponding setting of AI1 lower limit | 0.0% | -300.0-300.0% | |
| P05.44 | AI1 upper limit | 10.00V | P05.42-10.00V | |
| P05.45 | Corresponding setting of AI1 upper limit | 100.0% | -300.0-300.0% | |
| P05.46 | AI1 input filter time | 0.030s | 0.000-10.000s | |
| P05.47 | AI2 lower limit | -10.00V | 0.00V-P05.49 | |
| P05.48 | Corresponding setting of AI2 lower limit | -100.0% | -300.0-300.0% | |
| P05.49 | AI2 middle value 1 | 0.00V | P05.47-P05.51 | |
| P05.50 | Corresponding setting of AI2 middle value 1 | 0.0% | -300.0-300.0% | |
| P05.51 | AI2 middle value 2 | 0.00V | P05.49-P05.53 | |
| P05.52 | Corresponding setting of AI2 middle value 2 | 0.0% | -300.0-300.0% | |
| P05.53 | AI2 upper limit | 10.00V | P05.51-10.00V | |

| Function code | Name | Default | Setting range | Description |
|---------------|--|---------|---------------|---|
| P05.54 | Corresponding setting of AI2 upper limit | 100.0% | -300.0-300.0% | |
| P05.55 | AI2 input filter time | 0.030s | 0.000-10.000s | |
| P05.56 | AI3 lower limit | 0.00V | 0.00V-P05.58 | |
| P05.57 | Corresponding setting of AI3 lower limit | 0.0% | -300.0-300.0% | |
| P05.58 | AI3 upper limit | 10.00V | P05.56-10.00V | |
| P05.59 | Corresponding setting of AI3 upper limit | 100.0% | -300.0-300.0% | |
| P05.60 | AI3 input filter time | 0.030s | 0.000-10.000s | <p>Input filter time: to adjust the sensitivity of analog input. Increasing the value properly can enhance analog input anti-interference but may reduce the sensitivity of analog input.</p> <p>Note: AI1 supports the 0-10V/0-20mA input. When AI1 selects the 0-20mA input, the corresponding voltage of 20mA is 10V. AI2 supports the -10-+10V input. When AI2 selects the 0-20mA input, the corresponding voltage of 20mA is 10V.</p> |
| P05.76 | AI input signal type selection | 0x0 | 0x0-0x3 | <p>Bit0: AI1 input signal type selection 0: Voltage 1: Current Bit1: AI2 input signal type selection 0: Voltage 1: Current</p> |
| P17.19 | AI1 input voltage | 0.00V | 0.00-10.00V | Displays the AI1 input signal. |

| Function code | Name | Default | Setting range | Description |
|---------------|-------------------|---------|---------------|--------------------------------|
| P17.20 | AI2 input voltage | 0.00V | 0.00V–10.00V | Displays the AI2 input signal. |
| P17.21 | AI3 input voltage | 0.00V | 0.00V–10.00V | Displays the AI3 input signal. |

6.9.2.2 Analog output

The VFD carries one analog output terminal (supporting the output of 0–10V/0–20mA). Analog output signal can be filtered separately, and the proportional relationship can be adjusted by setting the max. value, min. value, and the percentage of their corresponding output. Analog output signal can output motor speed, output frequency, output current, motor torque and motor power at a certain proportion.

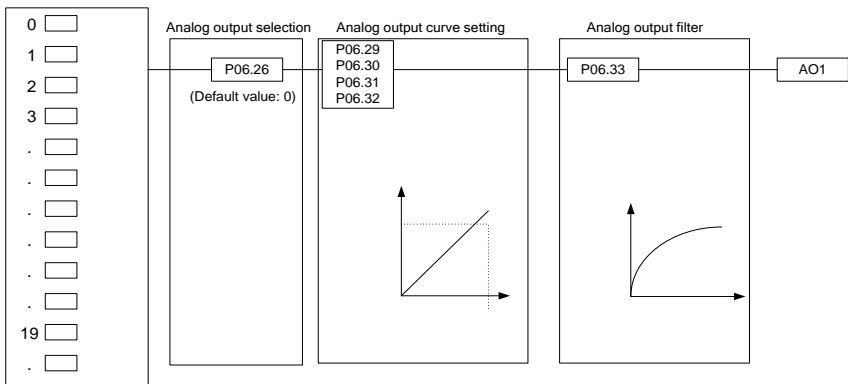

AO1 output relationship description:

(The min. value and max. value of the output correspond to 0.% and 100.00% of the analog default output. The actual output voltage corresponds to the actual percentage, which can be set through function codes.) Output functions are as follows.

| Setting | Function | Description |
|---------|--------------------------------------|--|
| 0 | Running frequency | 0–Max. output frequency |
| 1 | Set frequency | 0–Max. output frequency |
| 2 | Ramp reference frequency | 0–Max. output frequency |
| 3 | Rotation speed of running | 0–Synchronous speed corresponding to max. output frequency |
| 4 | Output current (relative to the VFD) | 0–Twice the VFD rated current |
| 5 | Output current (relative to motor) | 0–Twice the motor rated current |

| Setting | Function | Description |
|---------|---|---|
| 6 | Output voltage | 0–1.5 times the VFD rated voltage |
| 7 | Output power | 0–Twice the motor rated power |
| 8 | Set torque value (bipolar) | 0–Twice the motor rated current. A negative value corresponds to 0.0% by default. |
| 9 | Output torque (absolute value) | 0–Twice the motor rated torque, or -Twice the motor rated torque–0 |
| 10 | AI1 input value | 0–10V/0–20mA |
| 11 | AI2 input value | 0V–10V. A negative value corresponds to 0.0% by default. |
| 12 | AI3 input value | 0–10V |
| 14 | High-speed pulse HDI1 input | 0.00–50.00Hz |
| 16 | Value 1 set through Modbus/Modbus TCP communication | 0–1000 |
| 17 | Value 2 set through Modbus/Modbus TCP communication | 0–1000 |
| 20 | Value 1 set through Ethernet communication | 0–1000 |
| 21 | Value 2 set through Ethernet communication | 0–1000 |
| 22 | Value 1 set through EtherCAT/PROFINET/EtherNet IP communication | 0–1000 |
| 23 | Value 2 set through EtherCAT/PROFINET/EtherNet IP communication | 0–1000 |
| 24 | Torque current (bipolar) | 0–Three times the motor rated current. A negative value corresponds to 0.0% by default. |
| 25 | Exciting current | 0–Three times the motor rated current. A negative value corresponds to 0.0% by default. |
| 26 | Set frequency (bipolar) | 0–Max. output frequency. A negative value corresponds to 0.0% by default. |
| 27 | Ramp reference frequency (bipolar) | 0–Max. output frequency. A negative value corresponds to 0.0% by default. |
| 28 | Rotational speed (bipolar) | 0–Synchronous rotation speed corresponding to max. output frequency. A negative value corresponds to 0.0% by default. |

| Setting | Function | Description |
|---------|----------------------------------|---|
| 31 | Rotation speed of running | 0–Twice the motor rated synchronous rotation speed |
| 32 | Output torque (bipolar) | 0–Twice the motor rated torque. A negative value corresponds to 0.0% by default. |
| 33 | AIAO detected temperature output | AO output temperature in the AIAO temperature detection. |
| 40 | Specified function code value | The output value is calculated as follows: $(\text{Specified function value}/\text{Base value}) * 100.00\% + \text{Offset}$ The function is configured by function codes P06.59–P06.61. |

Related parameters are listed in the following.

| Function code | Name | Default | Setting range | Description |
|---------------|---|---------|-----------------|--|
| P06.26 | AO1 output | 0 | 0–63 | For details, see the preceding table. |
| P06.29 | AO1 output lower limit | 0.0% | -300.0%– P06.31 | The function codes define the relationship between the output value and analog output. When the output value exceeds the allowed range, the output uses the lower limit or upper limit. When the analog output is current output, 1mA equals 0.5V. In different cases, the corresponding analog output of 100% of the output value is different. |
| P06.30 | AO1 output corresponding to lower limit | 0.00V | 0.00–10.00V | |
| P06.31 | AO1 output upper limit | 100.0% | P06.29– 300.0% | |
| P06.32 | AO1 output corresponding to upper limit | 10.00V | 0.00–10.00V | |
| P06.33 | AO1 output filter time | 0.000s | 0.000–10.000s | |

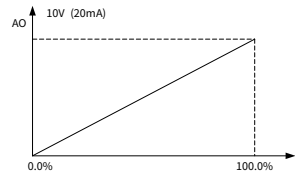

6.9.3 High-speed pulse input and output terminal functions

6.9.3.1 High-speed pulse input

The VFD supports one high-speed pulse input HDI1. HDI1 input can be filtered separately,

and the corresponding reference curve can be set by adjusting the reference values correspond to the max. value and min. values.

⚡**Note:** HDI1 high-speed pulse input ranges from 0.000kHz to 50.000kHz.

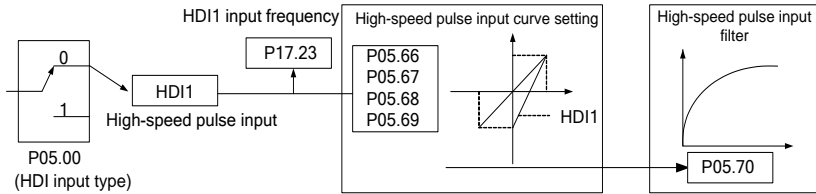

Related parameters are listed in the following.

| Function code | Name | Default | Setting range | Description |
|---------------|---|---------|---------------|---|
| P00.06 | Setting channel of A frequency command | 0 | 0–15 | 5: High-speed pulse HDI1 ⚡ Note: To select high-speed pulse setting, set P05.00 to 0. |
| P00.07 | Setting channel of B frequency command | 1 | 0–15 | |
| P03.11 | Torque setting method selection | 0 | 0–15 | |
| P03.14 | Forward rotation upper-limit frequency source in torque control for motor 1 | 0 | 0–15 | |
| P03.15 | Reverse rotation upper-limit frequency source in torque control for motor 1 | 0 | 0–15 | |

| Function code | Name | Default | Setting range | Description |
|---------------|--|------------|------------------|---|
| P03.18 | Setting source of electromotive torque upper limit for motor 1 | 0 | 0–15 | |
| P03.19 | Setting source of braking torque upper limit for motor 1 | 0 | 0–15 | |
| P04.13 | Voltage setting channel selection | 0 | 0–15 | |
| P05.00 | HDI input type | 0 | 0–1 | 0: HDI1 is high-speed pulse input 1: HDI1 is digital input |
| P05.66 | HDI1 lower limit frequency | 0.000kHz | 0.000kHz–P05.68 | - |
| P05.67 | Corresponding setting of HDI1 lower limit frequency | 0.0% | -300.0–300.0% | - |
| P05.68 | HDI1 upper limit frequency | 50.000 kHz | P05.66–50.000kHz | - |
| P05.69 | Corresponding setting of HDI1 upper limit frequency | 100.0% | -300.0–300.0% | - |
| P05.70 | HDI1 frequency input filter time | 0.030s | 0.000–10.000s | - |
| P17.23 | HDI1 input frequency | 0.000kHz | 0.000–50.000kHz | - |

6.9.3.2 High-speed pulse output

The VFD carries one high-speed pulse output terminal. High-speed pulse output signals

can be filtered separately, and the proportional relationship can be adjusted by setting the max. value, min. value, and the percentage of their corresponding output. High-speed pulse output signals can output the motor speed, output frequency, output current, motor torque and motor power at a certain proportion.

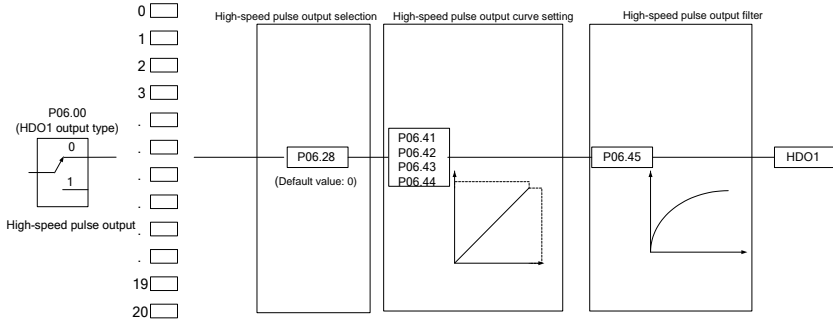

HDO1 output relationship description:

(The min. value and max. value of the output correspond to 0.0% and 100.00% of the default output. The actual output pulse frequency corresponds to the actual percentage, which can be set through function codes.)

Note: To use HDO1 to output any of the following functions, you need to select HDO1 as high-speed pulse output by setting P06.00 to 1. The high-speed pulse output ranges from 0.00kHz to 50.00kHz. Output functions are as follows.

| Setting | Function | Description |
|---------|--------------------------------------|---|
| 0 | Running frequency | 0–Max. output frequency |
| 1 | Set frequency | 0–Max. output frequency |
| 2 | Ramp reference frequency | 0–Max. output frequency |
| 3 | Rotation speed of running | 0–Synchronous speed corresponding to max. output frequency |
| 4 | Output current (relative to the VFD) | 0–Twice the VFD rated current |
| 5 | Output current (relative to motor) | 0–Twice the motor rated current |
| 6 | Output voltage | 0–1.5 times the VFD rated voltage |
| 7 | Output power | 0–Twice the motor rated power |
| 8 | Set torque value (bipolar) | 0–Twice the motor rated current. A negative value corresponds to 0.0% by default. |
| 9 | Output torque (absolute value) | 0–Twice the motor rated torque, or -Twice the motor rated torque–0 |
| 10 | All input value | 0–10V/0–20mA |

| Setting | Function | Description |
|---------|---|---|
| 11 | AI2 input value | 0V–10V. A negative value corresponds to 0.0% by default. |
| 12 | AI3 input value | 0–10V |
| 14 | High-speed pulse HDI1 input | 0.00–50.00Hz |
| 16 | Value 1 set through Modbus/Modbus TCP communication | 0–1000 |
| 17 | Value 2 set through Modbus/Modbus TCP communication | 0–1000 |
| 20 | Value 1 set through Ethernet communication | 0–1000 |
| 21 | Value 2 set through Ethernet communication | 0–1000 |
| 22 | Value 1 set through EtherCAT/PROFINET/EtherNet IP communication | 0–1000 |
| 23 | Value 2 set through EtherCAT/PROFINET/EtherNet IP communication | 0–1000 |
| 24 | Torque current (bipolar) | 0–Three times the motor rated current. A negative value corresponds to 0.0% by default. |
| 25 | Exciting current | 0–Three times the motor rated current. A negative value corresponds to 0.0% by default. |
| 26 | Set frequency (bipolar) | 0–Max. output frequency. A negative value corresponds to 0.0% by default. |
| 27 | Ramp reference frequency (bipolar) | 0–Max. output frequency. A negative value corresponds to 0.0% by default. |
| 28 | Rotational speed (bipolar) | 0–Synchronous rotation speed corresponding to max. output frequency. A negative value corresponds to 0.0% by default. |
| 31 | Rotation speed of running | 0–Twice the motor rated synchronous rotation speed |
| 32 | Output torque (bipolar) | 0–Twice the motor rated torque. A negative value corresponds to 0.0% by default. |

| Setting | Function | Description |
|---------|----------------------------------|---|
| 33 | AIAO detected temperature output | AO output temperature in the AIAO temperature detection. |
| 40 | Specified function code value | The output value is calculated as follows: (Specified function value/Base value) * 100.00% + Offset The function is configured by function codes P06.59–P06.61. |

Related parameters are listed in the following.

| Function code | Name | Default | Setting range | Description |
|---------------|--|----------|-----------------|--|
| P06.00 | HDO1 output type | 0 | 0–1 | 0: High-speed pulse output 1: Digital output Note: HDO1 uses push-pull output. |
| P06.41 | HDO1 output lower limit | 0.0% | -300.0%– P06.43 | - |
| P06.42 | HDO1 output corresponding to lower limit | 0.00kHz | 0.00–50.00Hz | - |
| P06.43 | HDO1 output upper limit | 100.0% | P06.41– 300.0% | - |
| P06.44 | HDO1 output corresponding to upper limit | 50.00kHz | 0.00–50.00Hz | - |
| P06.45 | HDO1 output filter time | 0.000s | 0.000–10.000s | - |

6.10 RS485 communication

The communication addresses on the communication network are unique, which is the basis of the point-to-point communication between the host controller and VFD. If the slave communication address in the message frame sent from the host controller is set to 0, it serves as a broadcast communication address. All slaves on the Modbus bus will receive the frame, but the slaves will not respond to it. The local communication address is specified by P14.00. The communication response delay is specified by P14.03, and the RS485 communication timeout time is specified by P14.04.

There are four transmission error processing methods, which can be selected through P14.05.

| Function code | Name | Default | Setting range | Description |
|---------------|---------------------------------|---------|---------------|---|
| P14.00 | Local communication address | 1 | 1–247 | The communication address of a slave cannot be set to 0. |
| P14.01 | Communication baud rate setting | 4 | 0–7 | Used to set the rate of data transmission between the host controller and the VFD. 0: 1200 bps 1: 2400 bps 2: 4800 bps 3: 9600 bps 4: 19200 bps 5: 38400 bps 6: 57600 bps 7: 115200 bps Note: The baud rate set on the VFD must be consistent with that on the host controller. Otherwise, the communication fails. A greater baud rate indicates faster communication. |
| P14.02 | Data bit check setting | 1 | 0–5 | The data format set on the VFD must be consistent with that on the host controller. Otherwise, the communication fails. 0: No check (N, 8, 1) for RTU 1: Even check (E, 8, 1) for RTU 2: Odd check (O, 8, 1) for RTU 3: No check (N, 8, 2) for RTU 4: Even check (E, 8, 2) for RTU 5: Odd check (O, 8, 2) for RTU |
| P14.03 | Communication response delay | 5ms | 0–200ms | Indicates the communication response delay, that is, the interval from when the VFD completes receiving data to when it sends response data to the host controller. If the response delay is shorter than the rectifier |

| Function code | Name | Default | Setting range | Description |
|---------------|--|---------|---------------------|--|
| | | | | processing time, the rectifier sends response data to the host controller after processing data. If the delay is longer than the rectifier processing time, the rectifier does not send response data to the host controller until the delay is reached although data has been processed. |
| P14.04 | RS485 communication timeout time | 0.0s | 0.0 (invalid)–60.0s | When P14.04 is set to 0.0, the communication timeout time is invalid. When P14.04 is set to a non-zero value, the system reports the "RS485 communication fault" (E18) if the communication interval exceeds the value. In general, the function code is set to 0.0. When continuous communication is required, you can set the function code to monitor communication status. |
| P14.05 | Transmission fault processing | 0 | 0–3 | 0: Report an alarm and coast to stop 1: Keep running without reporting an alarm 2: Stop in enabled stop mode without reporting an alarm (applicable only to communication mode) 3: Stop in enabled stop mode without reporting an alarm (applicable to any mode) |
| P14.06 | Modbus communication processing action selection | 0x0000 | 0x000–0x1111 | Ones place: 0: Respond to write operations 1: Not respond to write operations Tens place: 0: Communication password |

| Function code | Name | Default | Setting range | Description |
|---------------|------|---------|---------------|--|
| | | | | protection is invalid. 1: Communication password protection is valid. Hundreds place: 0: User-defined addresses specified in group P16 are invalid. 1: User-defined addresses specified in group P16 are valid. Thousands place: 0: CRC failure, with response of error type 0x06 1: CRC checksum failure, without response |

6.11 Monitoring parameters

Monitoring parameters mainly fall in groups P07 and P17, which are used to view and analyze the VFD control and use status. The monitored content is listed in the following.

| Group | Type | Monitored content |
|-----------|----------------------|---|
| Group P07 | HMI | VFD information, module temperature, run time, power usage, fault history, and software version. |
| Group P17 | Basic status viewing | Frequency information Current information Voltage information Torque and power information Input terminal information Output terminal information PID regulator information Control word and status word information |

6.11.1 Group P07—Human-machine interface

| Function code | Name | Default | Setting range | Description |
|---------------|-----------------------------|------------------|---------------|-------------|
| P07.12 | Inverter module temperature | 0.0°C | -20.0–120.0°C | - |
| P07.13 | Control software version | Version depended | 1.00–655.35 | - |

| Function code | Name | Default | Setting range | Description |
|---------------|------------------------|------------------|---------------|---|
| P07.14 | Drive software version | Version depended | 1.00–655.35 | - |
| P07.17 | VFD model | 0x0000 | 0x0000–0xFFFF | Bit0–bit3: Reserved Bit4–bit11: Chip type and manufacturer 0x00: DSP(TI) 0x01–0xFF: Reserved Bit12–bit15: VFD series 0x0: GD28 0x1–0xF: Reserved Note: After power failure, the function parameters are saved to the control board rather than the drive board. |
| P07.18 | VFD rated power | Model depended | 0.2–3000.0kW | - |
| P07.19 | VFD rated voltage | Model depended | 50–1200V | - |
| P07.20 | VFD rated current | Model depended | 0.01–600.00A | - |
| P07.27 | Present fault type | 0 | 0–588 | 0: No fault |
| P07.28 | Last fault type | 0 | 0–588 | 4: Overcurrent during ACC (E4) |
| P07.29 | 2nd-last fault type | 0 | 0–588 | 5: Overcurrent during DEC (E5) |
| P07.30 | 3rd-last fault type | 0 | 0–588 | 6: Overcurrent during constant speed running (E6) |
| P07.31 | 4th-last fault type | 0 | 0–588 | 7: Overvoltage during ACC (E7) |
| P07.32 | 5th-last fault type | 0 | 0–588 | 8: Overvoltage during DEC (E8) |
| | | | | 9: Overvoltage during constant speed running (E9) |
| | | | | 10: DC bus undervoltage (E10) |
| | | | | 11: Motor overload (E11) |
| | | | | 12: VFD overload (E12) |
| | | | | 13: Phase loss on input side (E13) |
| | | | | 14: Phase loss on output side (E14) |
| | | | | 16: Inverter module overheat (E16) |
| | | | | 17: External fault (E17) |
| | | | | 18: Modbus/Modbus TCP |

| Function code | Name | Default | Setting range | Description |
|---------------|------|---------|---------------|--|
| | | | | communication fault (E18) 19: Current detection fault (E19) 20: Motor autotuning fault (E20) 21: EEPROM operation error (E21) 22: PID feedback offline fault (E22) 23: Braking unit fault (E23) 24: Running time reached (E24) 25: Electronic overload (E25) 27: Parameter upload error (E27) 28: Parameter download error (E28) 30: Ethernet communication fault (E30) 32: To-ground short-circuit fault (E32) 34: Speed deviation fault (E34) 35: Mal-adjustment fault (E35) 36: Underload fault (E36) 40: STO safe torque off (E40) 41: STO channel 1 safety circuit exception (E41) 42: STO channel 2 safety circuit exception (E42) 43: Exception in both STO channels 1 and 2 (E43) 44: STO safety code FLASH CRC fault (E44) 57: PROFINET communication timeout fault (E57) 59: Motor overtemperature fault (E59) 60: Communication card identifying failure (E60) 63: Communication card communication timeout fault (E63) 66: EtherCAT communication timeout fault (E66) 92: AI1 disconnection fault (E92) |

| Function code | Name | Default | Setting range | Description |
|---------------|---|---------|---------------|--|
| | | | | 93: AI2 disconnection fault (E93) 94: AI3 disconnection fault (E94) 95: EtherNet IP communication timeout (E95) 96: No upgrade bootload (E96) 587: Dual-CPU communication fault 1 (E587) 588: Dual-CPU communication fault 2 (E588) Others: Reserved |
| P07.33 | Running frequency at present fault | 0.00Hz | 0.00-600.00Hz | - |
| P07.34 | Ramp reference frequency at present fault | 0.00Hz | 0.00-600.00Hz | - |
| P07.35 | Output voltage at present fault | 0V | 0-1200V | - |
| P07.36 | Output current at present fault | 0.00A | 0.00-630.00A | - |
| P07.37 | Bus voltage at present fault | 0.0V | 0.0-2000.0V | - |
| P07.38 | Temperature at present fault | 0.0°C | -20.0-120.0°C | - |
| P07.39 | Input terminal status at present fault | 0x0000 | 0x0000-0xFFFF | - |
| P07.40 | Output terminal state at present fault | 0x0000 | 0x0000-0xFFFF | - |
| P07.44 | Running frequency at last fault | 0.00Hz | 0.00-600.00Hz | - |
| P07.45 | Ramp reference frequency at last fault | 0.00Hz | 0.00-600.00Hz | - |

| Function code | Name | Default | Setting range | Description |
|---------------|--|---------|---------------|-------------|
| P07.46 | Output voltage at last fault | 0V | 0–1200V | - |
| P07.47 | Output current at last fault | 0.00A | 0.00–630.00A | - |
| P07.48 | Bus voltage at last fault | 0.0V | 0.0–2000.0V | - |
| P07.49 | Temperature at last fault | 0.0°C | -20.0–120.0°C | - |
| P07.50 | Input terminal state at last fault | 0x0000 | 0x0000–0xFFFF | - |
| P07.51 | Output terminal state at last fault | 0x0000 | 0x0000–0xFFFF | - |
| P07.55 | Running frequency at 2nd-last fault | 0.00Hz | 0.00–600.00Hz | - |
| P07.56 | Ramp reference frequency at 2nd-last fault | 0.00Hz | 0.00–600.00Hz | - |
| P07.57 | Output voltage at 2nd-last fault | 0V | 0–1200V | - |
| P07.58 | Output current at 2nd-last fault | 0.00A | 0.00–630.00A | - |
| P07.59 | Bus voltage at 2nd-last fault | 0.0V | 0.0–2000.0V | - |
| P07.60 | Temperature at 2nd-last fault | 0.0°C | -20.0–120.0°C | - |
| P07.61 | Input terminal state at 2nd-last fault | 0x0000 | 0x0000–0xFFFF | - |
| P07.62 | Output terminal state at 2nd-last fault | 0x0000 | 0x0000–0xFFFF | - |
| P07.75 | Local accumulative running time Storage time | 0h | 0–65535h | - |

| Function code | Name | Default | Setting range | Description |
|---------------|--------------------------------------|---------|---------------|---|
| P07.76 | VFD electricity consumption high bit | 0kWh | 0-65535kWh | Used to display the electricity consumption of the VFD. |
| P07.77 | VFD electricity consumption low bit | 0kWh | 0.0-999.9kWh | VFD electricity consumption = P07.76*1000+P07.77 |

6.11.2 GroupP17—Basic status viewing

6.11.2.1 Basic status viewing

| Function code | Name | Default | Setting range | Description |
|---------------|--------------------|---------|---------------|---|
| P17.42 | Motor control mode | 0x000 | 0x000-0x122 | Ones place: Control mode 0: Vector 0 1: Vector 1 2: V/F control Tens place: Control status 0: Speed control 1: Torque control 2: Reserved Hundreds place: Motor number 0: Motor 1 1: Motor 2 |
| P17.65 | VFD status word 3 | 0x0000 | 0x0000-0xFFFF | Bit 0: Running protection flag Bit 1: Running Bit 2: Running direction (1=REV, 0=FWD) Bit 3: Jogging Bit 4: Alarming Bit 5: In fault Bit 6: Running paused Bit 7: In sleep Bit 8: In PoFF state Bit 9: Undervoltage due to transient power loss Bit 10: Overvoltage stall Bit 11: Pre-exciting |

| Function code | Name | Default | Setting range | Description |
|---------------|-------------------------------|---------|---------------|--|
| | | | | Bit 12: DC braking Bit 13: Identifying parameters Bit 14: Flux weakening (reserved) Bit 15: Reserved |
| P17.12 | Digital input terminal state. | 0x000 | 0x000–0x7FF | Displays the present digital input terminal state of the VFD. Bit 0: DI1 Bit 1: DI2 Bit 2: DI3 Bit 3: DI4 Bit 4: DI5 Bit 5: DI6 Bit 6: DI7 Bit 7: DI8 Bit 8–Bit 9: Reserved Bit 10: HDI1 |
| P17.13 | Digital output terminal state | 0x000 | 0x00–0x1F | Displays the present digital output terminal state of the VFD. Bit 1–Bit 2: Reserved Bit 3: HDO1 Bit 4: RO1 |

6.11.2.2 Frequency related information

| Function code | Name | Default | Setting range | Description |
|---------------|---------------------------|---------|---------------|--|
| P17.00 | Set frequency | 0.00Hz | 0.00Hz–P00.03 | Displays the present set frequency of the VFD. |
| P17.01 | Output frequency | 0.00Hz | 0.00Hz–P00.03 | Displays the present output frequency of the VFD. |
| P17.02 | Ramp reference frequency | 0.00Hz | 0.00Hz–P00.03 | Displays the present ramp reference frequency of the VFD. |
| P17.05 | Motor rotation speed | 0Rpm | 0–65535Rpm | Displays the present motor rotation speed. |
| P17.10 | Estimated motor frequency | 0.00Hz | 0.00–600.00Hz | Displays the estimated motor rotor frequency under the open-loop vector condition. |

| Function code | Name | Default | Setting range | Description |
|---------------|--|----------|------------------|--|
| P17.14 | Digital adjustment value | 0.00Hz | 0.00–600.00Hz | Displays the adjustment on the VFD through the UP/DOWN terminal. |
| P17.16 | Linear speed | 0 | 0–65535 | Displays the linear speed. |
| P17.23 | HDI1 input frequency | 0.000kHz | 0.000–50.000 kHz | Displays HDIA input frequency. |
| P17.45 | Forward rotation upper-limit frequency in torque control | 0.00Hz | 0.00–600.00Hz | Displays the forward rotation upper-limit frequency in torque control. |
| P17.46 | Reverse rotation upper-limit frequency in torque control | 0.00Hz | 0.00–600.00Hz | Displays the reverse rotation upper-limit frequency in torque control. |
| P17.51 | Frequency set by A source | 0.00Hz | 0.00–600.00Hz | Displays the frequency set by A source. |
| P17.52 | Frequency set by B source | 0.00Hz | 0.00–600.00Hz | Displays the frequency set by B source. |
| P17.59 | Actual carrier frequency | 0.000kHz | 0.000–15.000 kHz | Displays the actual carrier frequency. |

6.11.2.3 Voltage related information

| Function code | Name | Default | Setting range | Description |
|---------------|-------------------|---------|---------------|---|
| P17.03 | Output voltage | 0V | 0–1200V | Displays the present output voltage of the VFD. |
| P17.11 | DC bus voltage | 0.0V | 0.0–2000.0V | Displays the present DC bus voltage of the VFD. |
| P17.19 | AI1 input voltage | 0.00V | 0.00–10.00V | Displays the AI1 input signal. |
| P17.20 | AI2 input voltage | 0.00V | 0.00V–10.00V | Displays the AI2 input signal. |
| P17.21 | AI3 input voltage | 0.00V | 0.00V–10.00V | Displays the AI3 input signal. |

6.11.2.4 Current related information

| Function code | Name | Default | Setting range | Description |
|---------------|----------------------------|---------|-----------------|--|
| P17.04 | Output current | 0.00A | 0.00–500.00A | Displays the valid value of present output current of the VFD. |
| P17.06 | Torque current | 0.00A | -300.00–300.00A | Displays the present torque current of the VFD. |
| P17.07 | Exciting current | 0.00A | -300.00–300.00A | Displays the present exciting current of the VFD. |
| P17.35 | Exciting current reference | 0.00A | -300.00–300.00A | Displays the exciting current reference value under the vector control mode. |
| P17.36 | Torque current reference | 0.00A | -300.00–300.00A | Displays the torque current reference value under the vector control mode. |

6.11.2.5 Torque and power related information

| Function code | Name | Default | Setting range | Description |
|---------------|---------------------|---------|---------------------------------------|--|
| P17.08 | Motor power | 0.0% | -300.0%–300.0% (Motor rated power) | Displays the present motor power; 100% is relative to the rated motor power. A positive value indicates it is the motoring state while a negative value indicates it is in the generating state. |
| P17.09 | Motor output torque | 0.0% | -250.0%–250.0% | Displays the present output torque of the VFD; 100% is relative to the motor rated torque. During forward running, the positive value is the motoring state while the negative value is generating state. During reverse running, the positive value is the generating state while the negative value is the motoring state. |

| Function code | Name | Default | Setting range | Description |
|---------------|----------------------------------|---------|---|---|
| P17.15 | Torque reference value | 0.0% | -300.0%–300.0% (of the motor rated current) | Relative to the percentage of the rated torque of the present motor, displaying the torque reference. |
| P17.27 | Motor power factor | 1.00 | -1.00–1.00 | Displays the power factor of the current motor. |
| P17.38 | Output torque | 0.0Nm | -3000.0–3000.0 Nm | Displays the output torque value. During forward running, the positive value is the motoring state while the negative value is generating state. During reverse running, the positive value is the generating state while the negative value is the motoring state. |
| P17.43 | Electromotive torque upper limit | 0.0% | 0.0%–300.0% (of the motor rated current) | Displays the electromotive torque upper limit. |
| P17.44 | Braking torque upper limit | 0.0% | 0.0%–300.0% (of the motor rated current) | Displays the braking torque upper limit. |
| P17.47 | Inertia compensation torque | 0.0% | -100.0%–100.0% | Displays the inertia compensation torque. |
| P17.48 | Friction compensation torque | 0.0% | -100.0%–100.0% | Displays the friction compensation torque. |

6.11.2.6 PID regulator information

| Function code | Name | Default | Setting range | Description |
|---------------|---------------------|---------|----------------|-----------------------------------|
| P17.25 | PID reference value | 0.0% | -100.0%–100.0% | Displays the PID reference value. |
| P17.26 | PID feedback value | 0.0% | -100.0%–100.0% | Displays the PID feedback value. |

| Function code | Name | Default | Setting range | Description |
|---------------|-------------------------------|---------|----------------|---|
| P17.53 | PID proportional output | 0.00% | -100.0%~100.0% | Displays the PID proportional output. |
| P17.54 | PID integral output | 0.00% | -100.0%~100.0% | Displays the PID integral output. |
| P17.55 | PID differential output | 0.00% | -100.0%~100.0% | Displays the PID differential output. |
| P17.56 | PID present proportional gain | 0.00% | 0.00~100.00% | Displays the PID present proportional gain. |
| P17.57 | PID present integral time | 0.00s | 0.00~10.00s | Displays the PID present integral time. |
| P17.58 | PID present differential time | 0.00s | 0.00~10.00s | Displays the PID present differential time. |
| P17.40 | Process PID output | 0.00% | -100.0%~100.0% | Displays the process PID output. |

6.12 Protection parameter setting

6.12.1 Overvoltage stall protection

When the motor is in power generation state (the motor speed is greater than the output frequency), the VFD bus voltage will increase continuously. When the detected bus voltage exceeds the value of P11.04 (Overvoltage stalling protection voltage), the overvoltage stalling protection function adjusts the output frequency based on the VFD ACC/DEC status (to be specific, if the VFD is in the ACC or constant speed state, the VFD will increase the output frequency; if the VFD is in the DEC state, the VFD will increase the DEC time). In this way, the regenerative energy on the bus can be consumed, preventing against VFD overvoltage. If the function does not meet requirements in the actual application, you can adjust parameters related to the current loop and voltage loop.

Figure 6-1 Actions taken for protection against overvoltage stall

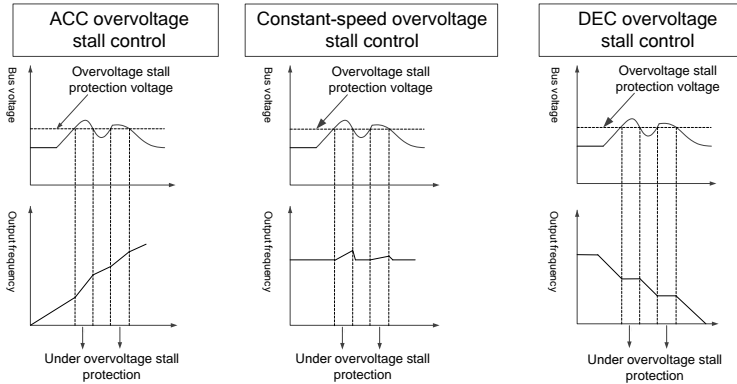

| Function code | Name | Default | Setting range | Description |
|---------------|--|---------|--|---|
| P11.03 | Overvoltage stall protection | 1 | 0-1 | 0: Disable 1: Enable |
| P11.04 | Overvoltage stall protection Voltage | 136% | 120%–150% (of the standard bus voltage) | For 380V models, it is 136% by default. |
| | | 120% | 120%–150% (of the standard bus voltage) | For 220V models, it is 120% by default. |
| P11.21 | Proportional coefficient of voltage regulator during overvoltage stall | 60 | 0-127 | Specifies the proportional coefficient of the bus voltage regulator during overvoltage stalling. |
| P11.22 | Integral coefficient of voltage regulator during overvoltage stall | 5 | 0-1000 | Specifies the integral coefficient of the bus voltage regulator during overvoltage stalling. |
| P11.23 | Proportional coefficient of current regulator during overvoltage stall | 60 | 0-1000 | Specifies the proportional coefficient of the active current regulator during overvoltage stalling. |

| Function code | Name | Default | Setting range | Description |
|---------------|--|---------|---------------|---|
| P11.24 | Integral coefficient of current regulator during overvoltage stall | 250 | 0–2000 | Specifies the integral coefficient of the active current regulator during overvoltage stalling. |

6.12.2 Current-limit protection

During accelerated running, as the load is too large, the actual acceleration rate of motor is lower than that of output frequency, if no measures are taken, the VFD may trip due to overcurrent during acceleration.

Current-limit protection function detects output current during running, and compares it with the current-limit level defined by P11.06, if it exceeds the current-limit level, the VFD will run at stable frequency during accelerated running, or run in decreased frequency during constant-speed running; if it exceeds the current-limit level continuously, the VFD output frequency will drop continuously until reaching lower limit frequency. When the output current is detected to be lower than the current-limit level again, it will continue accelerated running. In some heavy load scenarios, you can increase the value of P11.06 to improve the VFD output torque.

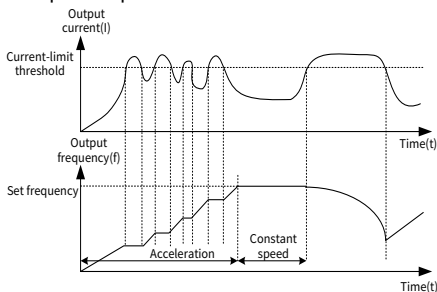

| Function code | Name | Default | Setting range | Description |
|---------------|-------------------------|---------|---------------|--|
| P11.05 | Current limit selection | 0x01 | 0x00–0x11 | Ones place: Current limit action selection 0: Invalid 1: Always valid Tens: Hardware current limit overload alarm selection 0: Valid 1: Invalid |

| Function code | Name | Default | Setting range | Description |
|---------------|--|-----------|----------------|--|
| P11.06 | Automatic current limit threshold | 160.0% | 50.0%–200.0% | 120.0% by default in light load mode; 160.0% by default in heavy load mode. Percentage of the VFD rated output current. |
| P11.07 | Frequency decrease ratio in current limiting | 10.00Hz/s | 0.00–50.00Hz/s | - |

6.12.3 Frequency decrease at sudden power failure

This function enables the system to keep running at sudden short-period power failure. When power failure occurs, the motor is in the power generation state, the bus voltage is kept at the action determination voltage for frequency decrease at sudden power failure, preventing the VFD from stop due to undervoltage.

If this function does not meet actual requirements, you can set parameters P11.17–P11.20. The speed loop dynamic response characteristics of vector control can be adjusted by setting the proportional coefficient and integral coefficient of speed regulator. Increasing proportional gain or reducing integral time can accelerate dynamic response of speed loop; however, if the proportional gain is too large or integral time is too small, system oscillation and overshoot may occur; If proportional gain is too small, stable oscillation or speed offset may occur.

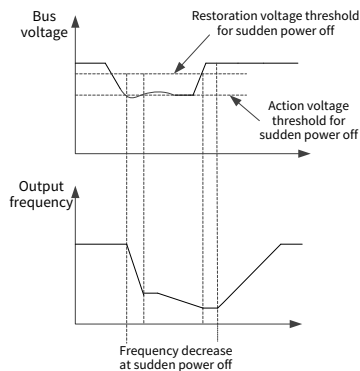

| Function code | Name | Default | Setting range | Description |
|---------------|---|---------|---------------|--|
| P11.01 | Frequency drop at transient power-off | 0 | 0–1 | 0: Disable 1: Enable |
| P11.17 | Proportional coefficient of voltage regulator during undervoltage stall | 20 | 0–127 | Specifies the integral coefficient of the bus voltage regulator during undervoltage stalling. |
| P11.18 | Integral coefficient of voltage regulator during undervoltage stall | 5 | 0–1000 | Specifies the integral coefficient of the bus voltage regulator during undervoltage stalling. |
| P11.19 | Proportional coefficient of current regulator during undervoltage stall | 20 | 0–1000 | Specifies the proportional coefficient of the active current regulator during undervoltage stalling. |
| P11.20 | Integral coefficient of current regulator during undervoltage stall | 20 | 0–2000 | Specifies the integral coefficient of the active current regulator during undervoltage stalling. |

6.12.4 Cooling fan control

The fan control mode is specified by P08.41, which allows you to select different running modes and speed regulation modes.

| Function code | Name | Default | Setting range | Description |
|---------------|--------------------------|---------|---------------|---|
| P08.41 | Cooling-fan running mode | 0x10 | 0x00–0x12 | Ones place: Run mode 0: Normal mode 1: Permanent running after power-on |

| Function code | Name | Default | Setting range | Description |
|---------------|------|---------|---------------|---|
| | | | | 2: Run mode 2 Tens place: Speed regulation mode 0: Disable speed regulation 1: Speed regulation mode 1 |

Note:

- The fan automatically runs in any mode if the VFD detects that the inverter module temperature is higher than 50°C.
- In addition to the normal running requirements, run mode 2 has the feature that the fan still runs even when the ramp frequency is greater than 0.

Running mode selection

Normal running mode: P08.41 ones place=0

The cooling fan runs when the VFD runs. The cooling fan stops 30s after the VFD stops.

Permanent running after power-on: P08.41 ones place=1

The cooling fan runs continuously as long as the VFD is powered on.

Running mode 2: P08.41 ones place=2

The cooling fan runs only when the VFD runs and the ramp frequency is greater than 0. The cooling fan stops 30s after the VFD stops.

Speed regulation mode

Full speed mode: P08.41 tens place=0

The fan cannot be speed regulated and runs at full speed.

Speed regulation mode: P08.41 tens place=1

The fan speed is regulated based on the inverter module temperature; as the temperature increases, the fan speed also increases.

6.12.5 Dynamic braking

When the VFD driving a high-inertia load decelerates or needs to decelerate abruptly, the motor runs in the power generation state and transmits the load-carrying energy to the DC circuit of the VFD, causing the bus voltage of the VFD to rise. If the bus voltage exceeds a specific value, the VFD reports an overvoltage fault. To prevent this from happening, you need to configure braking components.

You can set the following parameters for the VFD with a built-in dynamic braking unit:

When P08.39=1 and P11.02=1, and the bus voltage exceeds the dynamic braking voltage

threshold, the braking pipe is opened regardless of whether the VFD is running or stopped. If the bus voltage is less than dynamic braking voltage threshold minus 10V, the braking pipe is closed.

When P08.39=1 and P11.02=0, and the bus voltage exceeds the dynamic braking voltage threshold, the braking pipe is opened only when the VFD is running. If the bus voltage is less than dynamic braking voltage threshold minus 10V, the braking pipe is closed.

| Function code | Name | Default | Setting range | Description |
|---------------|--|--|---------------|---|
| P08.39 | Enabling dynamic braking | 0 | 0-1 | 0: Disable 1: Enable |
| P08.40 | Dynamic braking threshold voltage | For 220V: 380.0V For 380V: 700.0V | 200.0-2000.0V | Specifies the starting bus voltage of dynamic braking. Adjust this value properly to achieve effective braking for the load. The default value varies depending on the voltage class. |
| P11.02 | Enabling dynamic braking in standby mode | 0 | 0-1 | 0: Disable 1: Enable |

6.12.6 Safe torque off

You can enable the safe torque off (STO) function to prevent unexpected startups when the VFD main power supply is not switched off. The STO function switches off the VFD output by turning off the drive signals to prevent unexpected startups of the motor. For details, see Appendix F STO function.

| Function code | Name | Default | Setting range | Description |
|---------------|--------------------|---------|---------------|---|
| P08.55 | STO lock selection | 0 | 0-1 | 0: Lock upon STO alarm Lock upon STO alarm: indicates resetting is required after state restoration if STO occurs. 1: No lock upon STO alarm No lock upon STO alarm: Indicates that the STO alarm will automatically clear after state recovery from STO. |

6.13 Typical applications

6.13.1 Counting

When photoelectric switch pulse signals need to be collected, you can use multifunction digital input terminals to collect signals. That is, set P05.01–P05.04 or P05.11 to 31 (to trigger the counter). To use the HDI counting function, set P05.00 to 1 first.

When P17.18 (Accumulative value) reaches P08.25 (Set counting value), counting restarts. Once the value of P17.18 equals that of P08.25, set the digital output function to 18 to output the ON signal. Similarly, once the value of P17.18 equals that of P08.26, set the digital output function to 19 to output the ON signal.

| Function code | Name | Default | Setting range | Description |
|---------------|-----------------------------|---------|---------------|--|
| P05.00 | HDI input type | 0 | 0–1 | 0: HDI1 is high-speed pulse input 1: HDI1 is digital input |
| P05.01 | Function of DI1 | 1 | 0–95 | 28: Reset the counter, that is, the counting value is cleared 31: Trigger the counter, that is, the counting value is accumulated |
| P05.02 | Function of DI2 | 4 | | |
| P05.03 | Function of DI3 | 7 | | |
| P05.04 | Function of DI4 | 0 | | |
| P05.11 | Function of HDI1 | 0 | | |
| P06.04 | HDO1 output | 0 | 0–63 | 0: Invalid 18: Set counting value reached 19: Specified counting value reached |
| P06.05 | RO1 output | 1 | | |
| P08.25 | Set counting value | 0 | P08.26–65535 | - |
| P08.26 | Designated counting value | 0 | 0–P08.25 | - |
| P17.18 | Accumulative counting value | 0 | 0–65535 | - |

6.13.2 Sleep and wakeup

According to energy saving requirements, the sleep function can be used in water supply scenarios. When the motor needs to run effectively, you can adjust the set frequency to wake up it. The timing diagram is as follows.

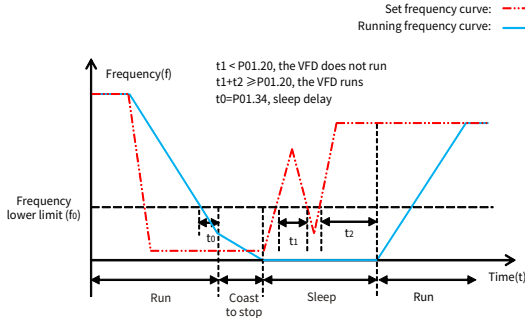

When the set frequency is lower than the frequency lower limit, and the ones place of P01.19 is set to sleep, the VFD stops according to the tens place of P01.19 and sleeps once running at the lower limit for the time specified by P01.34. If the set frequency is higher than the lower limit once again and it lasts for the time specified by P01.20, the VFD restores to the running state automatically and increases to the set frequency.

| Function code | Name | Default | Setting range | Description |
|---------------|--|---------|---------------|---|
| P01.19 | Action selected when running frequency less than frequency lower limit | 0 | 0x00-0x12 | The function code determines the running state of the VFD when the set frequency is lower than the lower-limit one. Ones place: Action selection 0: Run at the frequency lower limit 1: Stop 2: Sleep Tens place: Stop mode 0: Coast to stop 1: Decelerate to stop |
| P01.20 | Wake-up-from-sleep delay | 0.0s | 0.0-3600.0s | Valid only when P01.19ones place is 2. |
| P01.34 | Sleep delay | 0.0s | 0-3600.0s | - |

6.13.3 Switchover between FWD run and REV run

In scenarios with the needs of frequent switchover between FWD run and REV run, you can set P01.14 to increase the torque and stability in the process to decrease the current impact. When P01.14 = 0, the switching frequency point is zero (P01.15). When P01.14 = 1, the switching frequency point is starting frequency (P01.01). Refer to the following figure.

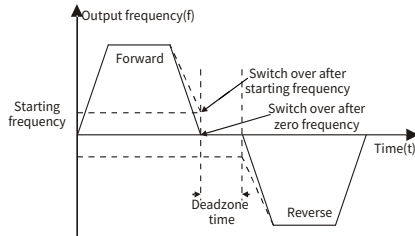

| Function code | Name | Default | Setting range | Description |
|---------------|----------------------------|---------|---------------|---|
| P01.14 | FWD/REV run switching mode | 1 | 0-2 | 0: Switch at zero frequency 1: Switch at the starting frequency 2: Switch after the speed reaches the stop speed with a delay |

Switch at the zero or starting frequency: P01.14=0 or 1

When P01.14=0 or 1, and the switchover between FWD run and REV run is valid, the VFD decelerates to the switching frequency point. If P01.16=1, check whether the motor output frequency is less than the switching frequency point. If yes, wait the time specified by P01.13, and then control the motor to run in the reverse direction. If no, wait the time specified by P01.17 and then the time specified by P01.13, and then control the motor to run in the reverse direction.

Switch after the speed reaches the stop speed with a delay: P01.14=2

When P01.14=2, the DEC process for the switchover between FWD run and REV run is similar to the process of deceleration to stop. In the DEC process for the switchover, you can set related parameters to determine whether to enable DC braking for stop and based on the work conditions. The difference between the two processes is as follows: When the running frequency reaches the stop speed specified by P01.15 or DC braking ends, the deadzone time specified by P01.13 needs to be waited, and then the motor can be controlled to run in the reverse direction.

| Function code | Name | Default | Setting range | Description |
|---------------|------------------------------------|---------|---------------|--|
| P01.01 | Starting frequency of direct start | 0.50Hz | 0.00Hz-P00.03 | The function code indicates the initial frequency during VFD start. |
| P01.02 | Starting frequency hold time | 0.0s | 0.0-50.0s | Setting a proper starting frequency can increase the torque during VFD start. During |

| Function code | Name | Default | Setting range | Description |
|---------------|---------------------------|---------|---------------|--|
| | | | | <p>the hold time of the starting frequency, the output frequency of the VFD is the starting frequency. And then, the VFD runs from the starting frequency to the set frequency. If the set frequency is lower than the starting frequency, the VFD stops running and keeps in the standby state. The starting frequency is not limited in the lower limit frequency.</p> |
| P01.13 | FWD/REV run deadzone time | 0.0s | 0.0–3600.0s | Specifies the transition time of the FWD/REV run switching, the mode of which is specified by P01.14. |
| P01.15 | Stop speed | 0.50Hz | 0.00Hz–P00.03 | - |
| P01.16 | Stop speed detection mode | 0 | 0–1 | 0: Detect by the set speed (unique in space voltage vector control mode) 1: Detect according to speed feedback |
| P01.17 | Stop speed detection time | 0.50s | 0.00–100.00s | - |

6.13.4 Jump frequency

The VFD can avoid mechanical resonance points by setting jump frequencies. The VFD has three jump frequency parameters P08.11, P08.13, and P08.15. If all jump frequencies are set to 0, this function is invalid. When the set frequency is within the jump frequency

range (Jump frequency $\pm 1/2 * \text{Jump amplitude}$), if the VFD is in the ACC phase, the VFD runs at the lower bound (Jump frequency $- 1/2 * \text{Jump amplitude}$); if the VFD is in the DEC phase, the VFD runs at the upper bound (Jump frequency $+ 1/2 * \text{Jump amplitude}$).

See the following figure.

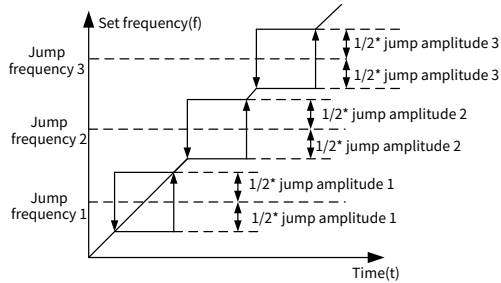

| Function code | Name | Default | Setting range | Description |
|---------------|------------------|---------|---------------|--|
| P08.11 | Jump frequency 1 | 0.00Hz | 0.00Hz–P00.03 | P00.03 specifies the max. output frequency. |
| P08.12 | Jump amplitude 1 | 0.00Hz | 0.00Hz–P00.03 | P00.03 specifies the max. output frequency. See P08.11 to set it. |
| P08.13 | Jump frequency 2 | 0.00Hz | 0.00Hz–P00.03 | P00.03 specifies the max. output frequency. |
| P08.14 | Jump amplitude 2 | 0.00Hz | 0.00Hz–P00.03 | P00.03 specifies the max. output frequency. See P08.13 to set it. |
| P08.15 | Jump frequency 3 | 0.00Hz | 0.00Hz–P00.03 | P00.03 specifies the max. output frequency. |
| P08.16 | Jump amplitude 3 | 0.00Hz | 0.00Hz–P00.03 | P00.03 specifies the max. output frequency. See P08.15 to set it. |

6.13.5 Wobbling frequency

Wobbling frequency is mainly applied in the scenarios where transverse movement and winding functions are needed such as textile and chemical fiber industries. The wobbling frequency function indicates that the VFD output frequency wobbles up or down with the set frequency as the center, and the output frequency with the wobbling frequency is impacted by the frequency upper and lower limits.

The time axis tracking is as shown in the following figure.

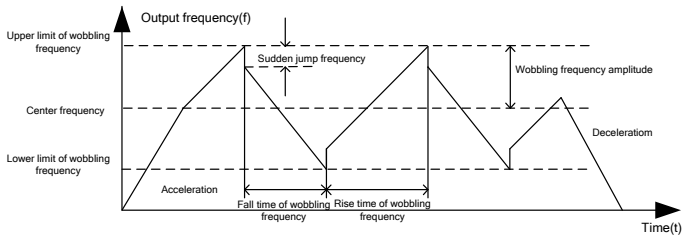

Wobbling frequency = Central frequency (Set frequency) x P08.17 (Amplitude of wobbling frequency)

Sudden jump frequency = Wobbling frequency x P08.18 (Amplitude of sudden jump frequency)

| Function code | Name | Default | Setting range | Description |
|---------------|------------------------------------|---------|---------------|--|
| P08.17 | Amplitude of wobbling frequency | 0.0% | 0.0–100.0% | Relative to the set frequency |
| P08.18 | Amplitude of sudden jump frequency | 0.0% | 0.0–50.0% | Relative to the wobbling frequency |
| P08.19 | Rise time of wobbling frequency | 5.0s | 0.1–3600.0s | Time taken to run from the lowest point of wobbling frequency to the highest point. |
| P08.20 | Fall time of wobbling frequency | 5.0s | 0.1–3600.0s | Time taken to run from the highest point of wobbling frequency to the lowest point. |
| P05.00 | HDI input type | 0 | 0–1 | 0: HDI1 is high-speed pulse input 1: HDI1 is digital input |
| P05.01 | Function of DI1 | 1 | 0–95 | 0: No function 26: Pause wobbling frequency (stopped at the present frequency) 27: Reset wobbling frequency (returned to the center frequency) |
| P05.02 | Function of DI2 | 4 | | |
| P05.03 | Function of DI3 | 7 | | |
| P05.04 | Function of DI4 | 0 | | |
| P05.11 | Function of HDI1 | 0 | | |

7 Communication

7.1 Standard communication interface

The VFD provides RS485 and USB communication as standard configuration. The following table lists the communication terminal functions.

Table 7-1 Standard communication terminal

| Interface type | Network signal | Signal description | Description |
|---------------------|----------------|---|---|
| IO terminal | 485+ 485- | RS485 communication | Terminal for external RS485 communication, supporting the Modbus communication protocol |
| USB Type-C terminal | USB | Internally converted serial communication | External USB Type-C communication terminal, supporting the Modbus communication protocol. |

Note: Both RS485 communication and the internally converted USB-serial communication support the Modbus protocol. However, they belong to two separate bus networks and can be connected to the master simultaneously. If both masters send commands such as start/stop or frequency reference to the VFD, the VFD responds in the order the commands are received. Additionally, both communication methods share the same communication parameters such as slave address, baud rate, and data bit verification format. However, the USB-converted serial communication does not support timeout fault detection. The USB driver can be downloaded from the INVT official website or installed via the Workshop software.

7.2 Communication data address

The communication data includes VFD-related function parameter data, VFD status parameter data, and VFD control parameter data.

7.2.1 Function parameter address

The address of a function code consists of two bytes, with the MSB on the left and LSB on the right. Both the MSB and LSB also range from 00–FFH. The MSB is the hexadecimal form of the group number on the left of the dot mark, and LSB is that of the number on the right of the dot mark. Take P05.06 as an example: The group number is 05, that is, the MSB of the parameter address is the hexadecimal form of 05; and the number behind the dot mark is 06, that is, the LSB is the hexadecimal form of 05. Therefore, the function code address is 0506H in the hexadecimal form. For P10.01, the parameter address is

0A01H.

Note:

- The parameters in the P99 group are set by the manufacturer and cannot be read or modified. Some parameters cannot be modified when the VFD is running; some cannot be modified regardless of the VFD status. Pay attention to the setting range, unit, and description of a parameter when modifying it.
- Frequently writing to EEPROM will reduce its life time. Some function codes do not need to be stored during communication. The application requirements can be met by modifying the value of the on-chip RAM, that is, modifying the highest-order bit of the corresponding function code address from 0 to 1. For example, if P00.07 is not to be stored in the EEPROM, you need only to modify the value in the RAM, that is, set the address to 8007H. The address can be used only for writing data to the on-chip RAM, and it is invalid when used for reading data.

7.2.2 Non-function parameter address

In addition to modifying the parameters of the VFD, the master can also control the VFD, such as starting and stopping it, and monitoring the operation status of the VFD. The following describes status parameter data addresses and control parameter data addresses.

1. Status parameters

Note: Status parameters are read only.

| Parameter | Address | Description |
|-------------------|---------|--|
| VFD status word 1 | 2100H | 0001H: Forward running |
| | | 0002H: Running reversely |
| | | 0003H: Stopped |
| | | 0004H: Faulty |
| | | 0005H: In POFF state |
| | | 0006H: In pre-exciting state |
| VFD status word 2 | 2101H | Bit0: =0: Not ready to run =1: Ready to run Bit2–Bit1: =00: Motor 1 =01: Motor 2 Bit3: =0: AM =1: SM Bit4: =0: No overload alarm =1: Overload alarm Bit6–Bit5: =00: Keypad-based control =01: Terminal-based control =10: Communication-based control Bit 7: Reserved Bit8: =0: Speed control =1: Torque control |

| Parameter | Address | Description |
|----------------------------------|---------|--|
| | | Bit 9: Reserved Bit11–Bit10: =00: Vector 0 =01: Vector 1 = 10: Space voltage vector |
| VFD fault code | 2102H | See the description of fault types. |
| VFD identification code | 2103H | 0x1202(GD28) |
| Running frequency | 3000H | 0–Fmax (Unit: 0.01Hz) |
| Set frequency | 3001H | 0–Fmax (Unit: 0.01Hz) |
| Bus voltage | 3002H | 0.0–2000.0V (Unit: 0.1V) |
| Output voltage | 3003H | 0–1200V (Unit: 1V) |
| Output current | 3004H | 0.00–300.0A (Unit: 0.01A) |
| Rotation speed of running | 3005H | 0–65535 (Unit: 1 RPM) |
| Output power | 3006H | -300.0%–300.0% (Unit: 0.1%) |
| Output torque | 3007H | -250.0%–250.0% (Unit: 0.1%) |
| PID setting | 3008H | -100.0%–100.0% (Unit: 0.1%) |
| PID feedback | 3009H | -100.0%–100.0% (Unit: 0.1%) |
| Input IO state | 300AH | 0x000–0x7FF Corresponding to the local terminals: HDI1/Reserved/Reserved/DI8/DI7/DI6/DI5/DI4/DI3/DI2/DI1 |
| Output IO state | 300BH | 0x00–0x1F Corresponding to the local terminals RO1/HDO1/Reserved/Reserved/Reserved |
| Analog input 1 | 300CH | 0.00–10.00V (Unit: 0.01V) |
| Analog input 2 | 300DH | 0.00–10.00V (Unit: 0.01V) |
| Analog input 3 | 300EH | 0.00–10.00V (Unit: 0.01V) |
| Read HDI1 high-speed pulse Input | 3010H | 0.00–50.00kHz (Unit: 0.01Hz) |
| Present step of simple PLC | 3012H | 0–15 |
| External counting value | 3014H | 0–65535 |
| Torque setting | 3015H | -300.0%–300.0% (Unit: 0.1%) |
| VFD identification code | 3016H | - |
| Fault code | 5000H | - |

2. Control parameter

 **Note:** VFD control parameters can be read and written.

| Parameter | Address | Description |
|-------------------------------------|---|---|
| Communication-based control command | 2000H | 0001H: Forward running |
| | | 0002H: Reverse running |
| | | 0003H: Forward jogging |
| | | 0004: Reverse jogging |
| | | 0005H: Stop |
| | | 0006H: Coast to stop |
| | | 0007H: Fault reset |
| | | 0008H: Jogging stop |
| | | 0009H: Emergency stop |
| Communication-based setting address | 2001H | Communication-based frequency setting (0–Fmax, unit: 0.01Hz) |
| | 2002H | PID reference (0–1000, in which 1000 corresponds to 100.0%) |
| | 2003H | PID feedback (0–1000, in which 1000 corresponds to 100.0%) |
| | 2004H | Torque setting (-3000–3000, in which 1000 corresponds to 100.0% of the motor rated current) |
| | 2005H | Upper limit setting of forward running frequency (0–Fmax; unit: 0.01Hz) |
| | 2006H | Upper limit setting of reverse running frequency (0–Fmax; unit: 0.01Hz) |
| | 2007H | Electromotive torque upper limit (0–3000, in which 1000 corresponds to 100.0% of the motor rated current) |
| | 2008H | Braking torque upper limit (0–3000, in which 1000 corresponds to 100.0% of the motor rated current) |
| | 2009H | Special control command word: Bit1–bit0=00: Motor 1 =01: Motor 2 Bit2: =1: Enable speed/torque control switchover =0: Disable speed/torque control switchover Bit3: =1: Clear electricity consumption data =0: Keep electricity consumption data Bit4: =1 Enable pre-excitation =0: Disable pre-excitation Bit5: =1: Enable DC braking =0: Disable DC braking |
| 200AH | Virtual input terminal command. Range: 0x000–0x7FF Corresponding to the local terminals: HDI1/Reserved/Reserved/DI8/DI7/DI6/DI5/DI4/DI3/DI2/DI1 | |

| Parameter | Address | Description |
|-----------|---------|--|
| | 200BH | Virtual output terminal command (0x00–0x1F) Corresponding to the local terminals RO1/HDO1/Reserved/Reserved/Reserved |
| | 200CH | Voltage setting (used for V/F separation) (0–1000, in which 1000 corresponds to 100.0% of the motor rated voltage) |
| | 200DH | AO setting 1 (-1000–+1000, in which 1000 corresponding to 100.0%) |
| | 200EH | AO setting 2 (-1000–+1000, in which 1000 corresponding to 100.0%) |

Note: Some parameters in the preceding table are valid only after they are enabled. For example, for the running or stop operation, you must set "Channel of running commands" (P00.01) to "Communication", and set "Communication channel of running commands" (P00.02) to "Modbus".

The following table describes the encoding rules of device codes (corresponding to the identification code 1200 H of the VFD).

| 8 MSBs | Meaning | 8 LSBs | Meaning |
|--------|-------------------------|--------|-----------------------|
| 0x12 | General mechanical type | 0x02 | Goodrive28 series VFD |

7.3 Modbus networking

A Modbus network is a control network with one master and multiple slaves, that is, on one Modbus network, there is only one device serving as the master, and other devices are the slaves. The master can communicate with any single slave or with all slaves. For separate access commands, a slave needs to return a response. For broadcast information, slaves do not need to return responses.

Generally, the PC, industry control device, or programmable logic controller (PLC) functions as the master, while VFDs function as slaves.

7.3.1 Network topology

7.3.1.1 Application to one VFD

Figure 7-1 Application to one VFD

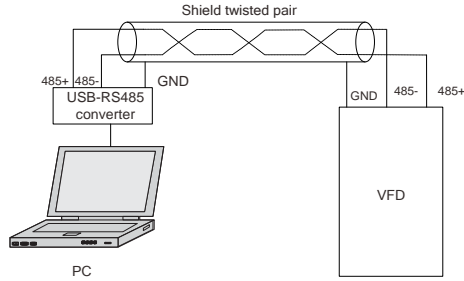

7.3.1.2 Application to multiple VFDs

In practical application to multiple VFDs, the daisy chain connection and star connection are commonly used.

Figure 7-2 Practical daisy chain connection application

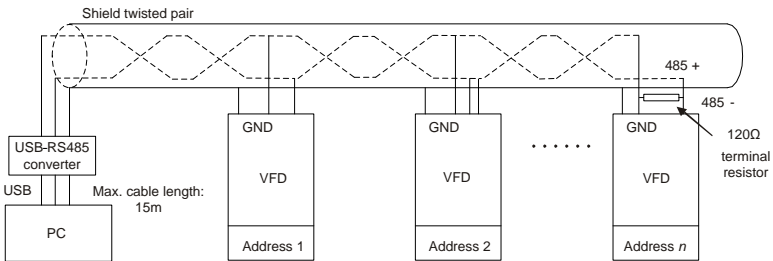
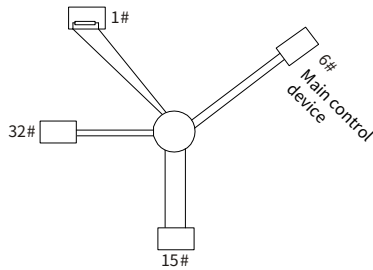

Figure 7-3 Star connection topology



Note:

- When this connection mode is adopted, the two devices that are farthest away from each other on the line must be connected with a terminal resistor (in the figure, the two devices are #1 device and #15 device).
- Use shielded cables, if possible, in multi-device connection. The baud rates, data bit check settings, and other basic parameters of all the devices on the RS485 line must be set consistently, and addresses cannot be duplicated.

7.3.2 RTU mode

7.3.2.1 RTU communication frame structure

When a controller is set to use the RTU communication mode on a Modbus network, every byte (including eight bits) in the message includes two hexadecimal characters (each includes four bits). Compared with the ASCII mode, the RTU mode achieves transmission of more data at the same baud rate.

In RTU mode, the transmission of a new frame always starts from an idle time (the transmission time of 3.5 bytes). On a network where the transmission rate is calculated based on the baud rate, the transmission time of 3.5 bytes can be easily obtained. After the idle time ends, the data domains are transmitted in the following sequence: slave address, command code, data, and CRC check character. Each byte transmitted in each domain includes 2 hexadecimal characters (0-9, A-F). The network devices always monitor the communication bus. After receiving the first domain (address information), each network device identifies the byte. After the last byte is transmitted, a similar transmission interval (the transmission time of 3.5 bytes) is used to indicate that the transmission of the frame ends. Then, the transmission of a new frame starts.

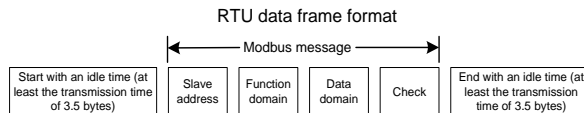

The information of a frame must be transmitted in a continuous data flow. If there is an interval greater than the transmission time of 1.5 bytes before the transmission of the entire frame is complete, the receiving device deletes the incomplete information, and mistakes the subsequent byte for the address domain of a new frame. Similarly, if the transmission interval between two frames is shorter than the transmission time of 3.5 bytes, the receiving device mistakes it for the data of the last frame. The CRC check value is incorrect due to the disorder of the frames, and thus a communication fault occurs.

If the slave detects a communication fault or read/write failure due to another cause, an error frame is replied.

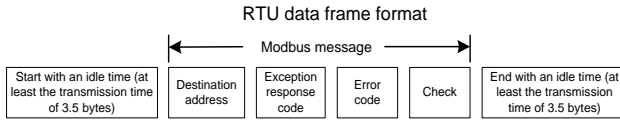

The following table describes the standard structure of an RTU frame.

| | |
|-------------------------------------|---|
| START (frame header) | T1-T2-T3-T4 (transmission time of 3.5 bytes) |
| ADDR (slave address domain) | Communication address: 0-247 (decimal system; 0 is the broadcast address) |
| CMD (function domain) | 03H: Read slave parameter; 06H: Write slave parameter |
| Data domain DATA (N-1)...DATA(0) | Data of 2*N bytes Main content of the communication as well as the core of data exchanging |
| CRC CHK LSB | Detection value: CRC (16 bits) |
| CRC CHK MSB | |
| END (frame tail) | T1-T2-T3-T4 (transmission time of 3.5 bytes) |

7.3.2.2 RTU communication frame error check methods

During the transmission of data, errors may occur due to various factors. Without error check, the data receiving device cannot identify data errors and may make an incorrect response. The incorrect response may cause severe problems. Therefore, the data must be checked.

The error check of a frame includes two parts, namely, bit check on individual bytes (that is, odd/even check using the check bit in the character frame), and whole data check (CRC check).

7.3.2.3 Bit check on individual bytes (odd/even check)

You can select the bit check mode as required, or you can choose not to perform the check, which will affect the check bit setting of each byte.

Definition of even check: Before the data is transmitted, an even check bit is added to indicate whether the number of "1" in the to-be-transmitted data is odd or even. If it is even, the check bit is set to "0"; and if it is odd, the check bit is set to "1".

Definition of odd check: Before the data is transmitted, an odd check bit is added to indicate whether the number of "1" in the to-be-transmitted data is odd or even. If it is odd, the check bit is set to "0"; and if it is even, the check bit is set to "1".

For example, the data bits to be sent are "11001110", including five "1". If the even check is applied, the even check bit is set to "1"; and if the odd check is applied, the odd check bit is set to "0". During the transmission of the data, the odd/even check bit is calculated

and placed in the check bit of the frame. The receiving device performs the odd/even check after receiving the data. If it finds that the odd/even parity of the data is inconsistent with the preset information, it determines that a communication error occurs.

7.3.2.4 Cyclic redundancy check (CRC)

A frame in the RTU format includes an error detection domain based on the CRC calculation. The CRC domain checks all the content of the frame. The CRC domain consists of two bytes, including 16 binary bits. It is calculated by the transmitter and added to the frame. The receiver calculates the CRC of the received frame, and compares the result with the value in the received CRC domain. If the two CRC values are not equal to each other, errors occur in the transmission.

During CRC, 0xFFFF is stored first, and then a process is invoked to process a minimum of 6 contiguous bytes in the frame based on the content in the current register. CRC is valid only for the 8-bit data in each character. It is invalid for the start, stop, and parity bits.

During the generation of the CRC values, the "exclusive or" (XOR) operation is performed on the each 8-bit character and the content in the register. The result is placed in the bits from the least significant bit (LSB) to the most significant bit (MSB), and 0 is placed in the MSB. Then, LSB is detected. If LSB is 1, the XOR operation is performed on the current value in the register and the preset value. If LSB is 0, no operation is performed. This process is repeated 8 times. After the last bit (8th bit) is detected and processed, the XOR operation is performed on the next 8-bit byte and the current content in the register. The final values in the register are the CRC values obtained after operations are performed on all the bytes in the frame.

The calculation adopts the international standard CRC check rule. You can refer to the related standard CRC algorithm to compile the CRC calculation program as required.

The following example is a simple CRC calculation function for your reference (using the C programming language):

```
unsigned int crc_cal_value (unsigned char*data_value, unsigned char
data_length)
{
    int i;
    unsigned int crc_value=0xffff;
    while (data_length--)
    {
        crc_value^=*data_value++;
        for (i=0;i<8;i++)
        {
```

```

        if (crc_value&0x0001)
            crc_value= (crc_value>>1)^0xa001;
        else
            crc_value=crc_value>>1;
    }
}
return (crc_value);
}

```

In the ladder logic, CKSM uses the table look-up method to calculate the CRC value according to the content in the frame. The program of this method is simple, and the calculation is fast, but the ROM space occupied is large. Use this program with caution in scenarios where there are space occupation requirements on programs.

7.3.3 RTU command code

7.3.3.1 Command code 03H, reading *N* words (continuously up to 16 words)

The command code 03H is used by the master to read data from the VFD. The count of data to be read depends on the "data count" in the command. A maximum of 16 pieces of data can be read. The addresses of the read parameters must be contiguous. Each piece of data occupies 2 bytes, that is, one word. The command format is presented using the hexadecimal system (a number followed by "H" indicates a hexadecimal value). One hexadecimal value occupies one byte.

The 03H command is used to read information including the parameters and running status of the VFD.

For example, if the master reads two contiguous pieces of data (that is, to read content from the data addresses 0004 H and 0005 H) from the VFD whose address is 01H, the command frame structure is described in the following.

RTU master command (from the master to the VFD) is as follows:

| | |
|--------------------|--|
| START | T1-T2-T3-T4 (transmission time of 3.5 bytes) |
| ADDR (address) | 01H |
| CMD (command code) | 03H |
| Start address MSB | 00H |
| Start address LSB | 04H |
| Data count MSB | 00H |
| Data count LSB | 02H |
| CRC LSB | 85H |
| CRC MSB | CAH |
| End | T1-T2-T3-T4 (transmission time of 3.5 bytes) |

"T1-T2-T3-T4 (transmission time of 3.5 bytes)" in "START" and "END" indicates that the RS485 communication needs to be idle for at least the transmission time of 3.5 bytes. An idle time is required to distinguish on message from another to ensure that the two messages are not regarded as one.

"ADDR" is "01H", indicating that the command is sent to the VFD whose address is 01H. "ADDR" occupies one byte.

"CMD" is "03H", indicating that the command is used to read data from the VFD. "CMD" occupies one byte.

"Start address" indicates the address from which data is read. "Start address" occupies two bytes, with the MSB on the left and LSB on the right.

"Data count" indicates the count of data to be read (unit: word). "Start address" is "0004H" and "Data count" is "0002H", which indicates reading data from the addresses 0004H and 0005H.

CRC check occupies two bytes, with the LSB on the left, and MSB on the right.

RTU slave response (from the VFD to the master) is as follows:

| | |
|------------------------|--|
| START | T1-T2-T3-T4 (transmission time of 3.5 bytes) |
| ADDR | 01H |
| CMD | 03H |
| Number of bytes | 04H |
| Address 0004H data MSB | 13H |
| Address 0004H data LSB | 88H |
| Address 0005H data MSB | 00H |
| Address 0005H data LSB | 00H |
| CRC LSB | 7EH |
| CRC MSB | 9DH |
| End | T1-T2-T3-T4 (transmission time of 3.5 bytes) |

The definition of the response information is described as follows:

"ADDR" is "01H", indicating that the command is sent from the VFD whose address is 01H. "ADDR" occupies one byte.

"CMD" is "03H", indicating that the message is a VFD response to the 03H command from the master for reading data. "CMD" occupies one byte.

"Number of bytes" indicates the number of bytes between the byte (not included) and the CRC byte (not included). The value "04" indicates that there are four bytes of data between "Number of bytes" and "CRC LSB", that is, "Address 0004H data MSB", "Address 0004H data LSB", "Address 0005H data MSB", and "Address 0005H data LSB".

A record of data contains two bytes, with the MSB on the left and LSB on the right. From

the response, the data in 0004H is 1388H, and that in 0005H is 0000H.

CRC check occupies two bytes, with the LSB on the left, and MSB on the right.

7.3.3.2 Command code 06H, writing a word

This command is used by the master to write data to the VFD. One command can be used to write only one piece of data. It is used to modify the parameters and running mode of the VFD.

For example, if the master writes 5000 (1388H) to 0004H of the VFD whose address is 02H,

RTU master command (from the master to the VFD) is as follows:

| | |
|-----------------------------|--|
| START | T1-T2-T3-T4 (transmission time of 3.5 bytes) |
| ADDR | 02H |
| CMD | 06H |
| MSB of data writing address | 00H |
| LSB of data writing address | 04H |
| Data content MSB | 13H |
| Data content LSB | 88H |
| CRC LSB | C5H |
| CRC MSB | 6EH |
| End | T1-T2-T3-T4 (transmission time of 3.5 bytes) |

RTU slave response (from the VFD to the master) is as follows:

| | |
|-----------------------------|--|
| START | T1-T2-T3-T4 (transmission time of 3.5 bytes) |
| ADDR | 02H |
| CMD | 06H |
| MSB of data writing address | 00H |
| LSB of data writing address | 04H |
| Data content MSB | 13H |
| Data content LSB | 88H |
| CRC LSB | C5H |
| CRC MSB | 6EH |
| End | T1-T2-T3-T4 (transmission time of 3.5 bytes) |

7.3.3.3 Command code 08H, diagnosis

Sub-function code description:

| Sub-function code | Description |
|-------------------|---|
| 0000 | Return data based on query information. |

For example, for the query about the circuit detection information about the VFD whose

address is 01H, the query and response strings are the same.

RTU master command:

| | |
|-----------------------|--|
| START | T1-T2-T3-T4 (transmission time of 3.5 bytes) |
| ADDR | 01H |
| CMD | 08H |
| Sub-function code MSB | 00H |
| Sub-function code LSB | 00H |
| Data content MSB | 12H |
| Data content LSB | ABH |
| CRC CHK LSB | ADH |
| CRC CHK MSB | 14H |
| End | T1-T2-T3-T4 (transmission time of 3.5 bytes) |

RTU slave response:

| | |
|-----------------------|--|
| START | T1-T2-T3-T4 (transmission time of 3.5 bytes) |
| ADDR | 01H |
| CMD | 08H |
| Sub-function code MSB | 00H |
| Sub-function code LSB | 00H |
| Data content MSB | 12H |
| Data content LSB | ABH |
| CRC CHK LSB | ADH |
| CRC CHK MSB | 14H |
| End | T1-T2-T3-T4 (transmission time of 3.5 bytes) |

7.3.3.4 Command code 10H, continuous writing

The command code 10H is used by the master to write data to the VFD. The quantity of data to be written is determined by data count, and a maximum of 16 pieces of data can be written.

For example: Write 5000 (1388H) and 50 (0032H) to 0004H and 0005H of the VFD (as the slave) whose address is 02H.

RTU master command (from the master to the VFD) is as follows:

| | |
|-----------------------------|--|
| START | T1-T2-T3-T4 (transmission time of 3.5 bytes) |
| ADDR | 02H |
| CMD | 10H |
| MSB of data writing address | 00H |
| LSB of data writing address | 04H |

| | |
|---------------------------|--|
| Data count MSB | 00H |
| Data count LSB | 02H |
| Number of bytes | 04H |
| MSB of data 0004H content | 13H |
| LSB of data 0004H content | 88H |
| MSB of data 0005H content | 00H |
| LSB of data 0005H content | 32H |
| CRC LSB | C5H |
| CRC MSB | 6EH |
| End | T1-T2-T3-T4 (transmission time of 3.5 bytes) |

RTU slave response (from the VFD to the master) is as follows:

| | |
|-----------------------------|--|
| START | T1-T2-T3-T4 (transmission time of 3.5 bytes) |
| ADDR | 02H |
| CMD | 10H |
| MSB of data writing address | 00H |
| LSB of data writing address | 04H |
| Data count MSB | 00H |
| Data count LSB | 02H |
| CRC LSB | C5H |
| CRC MSB | 6EH |
| End | T1-T2-T3-T4 (transmission time of 3.5 bytes) |

7.3.4 Fieldbus scale

In practical applications, communication data is represented in the hexadecimal form, but hexadecimal values cannot represent decimals. You can multiply a non-integer by a multiple to obtain an integer, in which the multiple is considered as a fieldbus scale.

The fieldbus scale depends on the number of decimal places in the value specified in "Setting range" or "Default". If there are n (for example, 1) decimal places in the value, the fieldbus scale m (then $m=10$) is the result of 10 to the power of n. For example:

| Function code | Name | Parameter description | Setting range | Default |
|---------------|--------------------------|---|---------------|---------|
| P01.20 | Wake-up-from-sleep delay | 0.0–3600.0s (Valid only when P01.19 ones place=2) | 0.00–3600.0 | 0.0s |

The value specified in "Setting range" or "Default" contains one decimal place, and therefore the fieldbus scale is 10. If the value received by the master is 50, "Wake-up-from-sleep delay" of the VFD is 5.0 ($5.0=50/10$).

To set "Wake-up-from-sleep delay" to 5.0s through Modbus communication, you need first to multiply 5.0 by 10 according to the scale to obtain an integer 50, that is, 32H in the hexadecimal form, and then send the following write command:

01 **06** **01 14** **00 32** **49 E7**
 VFD Write Parameter Parameter CRC
 address command address data

After receiving the command, the VFD converts 50 into 5.0 based on the fieldbus scale, and then sets "Wake-up-from-sleep delay" to 5.0s.

For another example, after sending the "Wake-up-from-sleep delay" parameter read command, the master receives the following response from the VFD:

01 **03** **02** **00 32** **39 91**
 VFD Read 2-byte Parameter CRC
 address command data data

The parameter data is 0032H, that is, 50, and therefore 5.0 is obtained based on the fieldbus scale (50/10=5.0). Then, the master confirms that the wake-up-from-sleep delay is 5.0s.

7.3.5 Error message response

Error message responses are sent from the VFD to the master. The following table lists the codes and definitions of the error message responses.

| Code | Name | Meaning |
|------|----------------------|---|
| 01H | Invalid command | The command code received by the upper computer is not allowed to be executed. The possible causes are as follows: <ul style="list-style-type: none"> • The function code is applicable only on new devices and is not implemented on this device. • The slave is in faulty state when processing this request. |
| 02H | Invalid data address | For the VFD, the data address in the request of the upper computer is not allowed. In particular, the combination of the register address and the number of the to-be-sent bytes is invalid. |
| 03H | Invalid data value | The received data domain contains a value that is not allowed. The value indicates the error of the remaining structure in the combined request. 📌 Note: It does not mean that the data item submitted for storage in the register includes a value unexpected by the program. |
| 04H | Operation failure | The parameter setting is invalid in the write operation. For example, a function input terminal cannot be set repeatedly. |

| Code | Name | Meaning |
|------|---|---|
| 05H | Incorrect password | The password entered in the password verification address is different from that is specified by P07.00. |
| 06H | Incorrect data frame | The data frame sent from the host controller is incorrect in the length, or in the RTU format, the value of the CRC check bit is inconsistent with the CRC value calculated by the downstream device. |
| 07H | Parameter read-only | The parameter to be modified in the write operation of the host controller is a read-only parameter. |
| 08H | Parameter cannot be modified in running | The parameter to be modified in the write operation of the host controller cannot be modified during the running of the VFD. |
| 09H | Password protection | If the host controller does not provide the correct password to unlock the system to perform a read or write operation, the error of "system being locked" is reported. |

7.3.6 Communication commissioning

In the following example, a PC is used as the master, an RS232-RS485 converter is used for signal conversion, and the PC serial port used by the converter is COM1 (an RS232 port). The host controller commissioning software is the serial port commissioning assistant Commix1.4, which can be downloaded from the Internet. Download a version that can automatically execute the CRC check function. The following figure shows the interface of Commix.

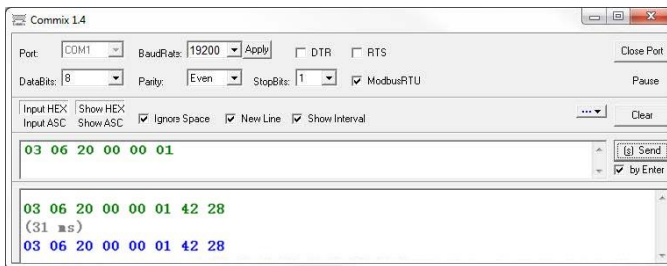

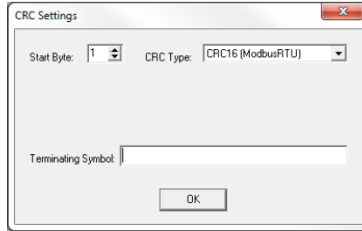

Set **Port** to **COM1**. Set **BaudRate** consistently with P14.01. **DataBits**, **Parity**, and **StopBits** must be set consistently with P14.02. If the RTU mode is selected, choose **Input HEX** and **Show HEX**. To implement automatic CRC, you need to choose **ModbusRTU**, and set **Start Byte** to **1** and **CRC Type** to **CRC16 (MODBU SRTU)** in the **CRC Settings** window. After the automatic CRC is enabled, do not enter CRC in commands. Otherwise, command errors may occur due to repeated CRC.

The commissioning command for setting the VFD whose address is 03H to run forward is as follows:

| | | | | |
|------------------|------------------|---------------------|---------------------|---------------------|
| <u>03</u> | <u>06</u> | <u>20 00</u> | <u>00 01</u> | <u>42 28</u> |
| VFD address | Write command | Parameter address | Forward running | CRC |

Note:

- The VFD address (P14.00) must be set to 03.
- "Channel of running commands" (P00.01) must be set to "Communication", and "Communication channel of running commands" (P00.02) to "Modbus".
- After you click **Send**, if the line configuration and settings are correct, a response transmitted by the VFD is received.

| | | | | |
|------------------|------------------|---------------------|---------------------|---------------------|
| <u>03</u> | <u>06</u> | <u>20 00</u> | <u>00 01</u> | <u>42 28</u> |
| VFD address | Write command | Parameter address | Forward running | CRC |

8 Fault handling

8.1 Fault indication and reset

When the RUN/TUNE, FWD/REV, and LOCAL/REMOT indicators are on at the same time, the VFD is in abnormal state, with the keypad showing the fault code. For details about fault causes and solutions, see section 8.2 Faults and solutions. If the fault cause cannot be located, contact our local office for technical support. There are four methods to reset VFD faults:

Method 1 Press the **STOP/RST** key on the keypad.

Method 2 Set P05.01–P05.04 and P05.11 to 7 (Fault reset).

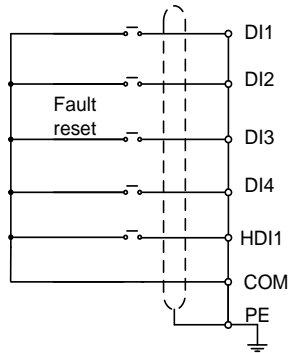

Method 3 Cut off the VFD power supply.

Method 4 In communication command control mode (P00.01=2), write 0007H to 2000H.

8.2 Faults and solutions

When a fault occurred, handle the fault as follows:

- Step 1 Check whether the keypad display is improper. If yes, contact the local INVT office.
- Step 2 If no, check the function codes in P07 group to determine the real state when the fault occurred.
- Step 3 Check the following table for the exception and solution.
- Step 4 Rectify the fault or ask for help.
- Step 5 After confirming the fault is removed, perform fault reset, and start running.

8.2.1 Common faults and solutions

| Fault code | Fault type | Possible cause | Solution |
|------------|------------------------|---|---|
| E4 | Overcurrent during ACC | <ul style="list-style-type: none"> ● ACC time too short. ● Load too large or sudden change of load. ● Start during motor rotating. ● 3PH output current imbalance. ● When sensorless vector control is used for motor control, parameter autotuning is not performed. ● When V/F control is used for motor control, V/F curve setting is abnormal. ● There are strong external interference sources (contactor switchover or improper grounding). ● Grid voltage is too low. ● Hardware fault. | <ul style="list-style-type: none"> ● Increase the ACC time, or reduce the software current limit point through P11.06; if the process requires rapid ACC, increase the VFD capacity. ● Increase the VFD capacity to ensure that the motor does not experience stalling, and that the load equipment functions without any exception. ● Start after the motor stops, or select speed tracking start through P01.00. ● Check the VFD output voltage and motor resistance to ensure three-phase balance. ● Set the rated parameters according to the motor nameplate, and perform parameter autotuning through P00.15. ● Adjust the frequency and voltage relationship set by the V/F curve, and reduce the voltage corresponding to the frequency. ● To avoid strong interference, keep the motor cables away from contactors and ensure reliable grounding of the system. ● Improve the power quality, or increase the VFD capacity. ● Replace the VFD. |
| E5 | Overcurrent during DEC | <ul style="list-style-type: none"> ● DEC time too short. ● Software current limit point setting too high. ● Load too large or sudden | <ul style="list-style-type: none"> ● Increase the DEC time, or reduce the software current limit point through P11.06; if the process requires rapid DEC, increase the |

| Fault code | Fault type | Possible cause | Solution |
|------------|---|---|---|
| | | <p>change of load.</p> <ul style="list-style-type: none"> ● 3PH output current imbalance. ● When sensorless vector control is used for motor control, parameter autotuning is not performed. ● When V/F control is used for motor control, V/F curve setting is abnormal. ● There are strong external interference sources (contactor switchover or improper grounding). ● Hardware fault. | <p>VFD capacity.</p> <ul style="list-style-type: none"> ● Reduce the software current limit point through P11.06. ● Increase the VFD capacity to ensure that the motor does not experience stalling, and that the load equipment functions without any exception. ● Check the VFD output voltage and motor resistance to ensure three-phase balance. ● Set the rated parameters according to the motor nameplate, and perform parameter autotuning through P00.15. ● Adjust the frequency and voltage relationship set by the V/F curve, and reduce the voltage corresponding to the frequency. ● To avoid strong interference, keep the motor cables away from contactors and ensure reliable grounding of the system. ● Replace the VFD. |
| E6 | Overcurrent during constant speed running | <ul style="list-style-type: none"> ● Load too large or sudden change of load. ● Software current limit point setting too high. ● 3PH output current imbalance. ● When sensorless vector control is used for motor control, parameter autotuning is not performed. ● When V/F control is used for motor control, V/F | <ul style="list-style-type: none"> ● Increase the VFD capacity to ensure that the motor does not experience stalling, and that the load equipment functions without any exception. ● Reduce the software current limit point through P11.06. ● Check the VFD output voltage and motor resistance to ensure three-phase balance. ● Set the rated parameters according to the motor nameplate, and perform |

| Fault code | Fault type | Possible cause | Solution |
|------------|------------------------|--|---|
| | | <p>curve setting is abnormal.</p> <ul style="list-style-type: none"> ● There are strong external interference sources (contactor switchover or improper grounding). ● Grid voltage is too low. ● Hardware fault. | <p>parameter autotuning through P00.15.</p> <ul style="list-style-type: none"> ● Adjust the frequency and voltage relationship set by the V/F curve, and reduce the voltage corresponding to the frequency. ● To avoid strong interference, keep the motor cables away from contactors and ensure reliable grounding of the system. ● Improve the power quality, or increase the VFD capacity. ● Replace the VFD. |
| E7 | Overvoltage during ACC | <ul style="list-style-type: none"> ● ACC time too short. ● Grid voltage too high. ● Start during motor rotating. ● Load energy regeneration is too large. ● Improper setting of overvoltage stall protection. | <ul style="list-style-type: none"> ● Increase the ACC time or enable overvoltage stall protection. ● Improve the power quality to comply with the VFD input voltage specifications (refer to product specifications). ● Start after the motor stops, or select speed tracking start through P01.00. ● Install a braking unit and energy feedback unit, or remove external factors that cause the load to generate power. ● Enable overvoltage stall protection through P11.03, and lower the overvoltage stall protection voltage value of P11.04. |
| E8 | Overvoltage during DEC | <ul style="list-style-type: none"> ● Deceleration time too short. ● Grid voltage too high. ● Load energy regeneration is too large. ● Improper setting of overvoltage stall | <ul style="list-style-type: none"> ● Increase the DEC time; if the process requires rapid DEC, braking units, energy feedback units can be added, or the magnetic flux braking function can be used. ● Improve the power quality to |

| Fault code | Fault type | Possible cause | Solution |
|------------|---|--|---|
| | | protection. | comply with the VFD input voltage specifications (refer to product specifications). <ul style="list-style-type: none"> ● Install a braking unit and energy feedback unit, or remove external factors that cause the load to generate power. ● Enable overvoltage stall protection through P11.03, and lower the overvoltage stall protection voltage value of P11.04. |
| E9 | Overvoltage during constant speed running | <ul style="list-style-type: none"> ● Grid voltage too high. ● Load energy regeneration is too large. ● Improper setting of overvoltage stall protection. | <ul style="list-style-type: none"> ● Improve the power quality to comply with the VFD input voltage specifications (refer to product specifications). ● Install a braking unit and energy feedback unit, or remove external factors that cause the load to generate power. ● Enable overvoltage stall protection through P11.03, and lower the overvoltage stall protection voltage value of P11.04. |
| E10 | DC bus undervoltage | <ul style="list-style-type: none"> ● Grid voltage is too low. ● Abnormal bus voltage display. ● Abnormal precharge contactor closing. ● Running under heavy load in the event of input phase loss. | <ul style="list-style-type: none"> ● Increase grid input voltage. ● Contact us. ● Contact us. ● Check for abnormal input power and loose input cables. |
| E11 | Motor overload | <ul style="list-style-type: none"> ● Grid voltage is too low. ● Motor rated current is set incorrectly. ● Motor stall or load jumps | <ul style="list-style-type: none"> ● Increase grid input voltage. ● Reset the motor rated current in the motor parameter group. ● Check the load and adjust torque |

| Fault code | Fault type | Possible cause | Solution |
|------------|---------------------------------|---|--|
| | | violently. | boost. |
| E12 | VFD overload | <ul style="list-style-type: none"> ● ACC is too fast. ● The motor is restarted during rotating. ● Grid voltage is too low. ● Load is too heavy. ● VFD power is too small. | <ul style="list-style-type: none"> ● Increase ACC time. ● Avoid restart after stop. ● Increase grid input voltage. ● Select a VFD with larger power. |
| E13 | Input side phase loss | <ul style="list-style-type: none"> ● Phase loss or significant fluctuations in input L1, L2, or L3. ● Input-side screws are loose. | <ul style="list-style-type: none"> ● Check for abnormal input power and loose input cables. ● Set P11.00 to screen out the fault. |
| E14 | Output side phase loss | <ul style="list-style-type: none"> ● Output cables are broken or short connected to the ground. ● UVW phase loss (or the three phases of load are seriously asymmetrical). <p>Note: The output phase loss detection time requires at least 2.5s. After phase loss, instability may occur, potentially triggering overcurrent, overvoltage, overload, and speed deviation faults.</p> | <ul style="list-style-type: none"> ● Check for loose or broken output cables. ● Check for sharp load fluctuation and motor 3PH resistance imbalance. |
| E16 | Inverter module overheat | <ul style="list-style-type: none"> ● Air duct is blocked or fan is damaged. ● Ambient temperature is too high. ● Long-time overload running. | <ul style="list-style-type: none"> ● Ventilate the air duct or replace the fan. ● Keep good ventilation to lower ambient temperature. ● Select a VFD with larger power. |
| E17 | External fault | <ul style="list-style-type: none"> ● DI terminal external fault input signal acted. | <ul style="list-style-type: none"> ● Check whether external device input is normal. |
| E18 | Modbus/Modbus TCP communication | <ul style="list-style-type: none"> ● Incorrect baud rate ● Communication line fault. | <ul style="list-style-type: none"> ● Set a proper baud rate. ● Check the communication port wiring. |

| Fault code | Fault type | Possible cause | Solution |
|------------|-------------------------|---|---|
| | fault | <ul style="list-style-type: none"> ● Incorrect communication address. ● Communication suffers from strong interference. | <ul style="list-style-type: none"> ● Set the communication address correctly. ● You are recommended to use shielded cables to improve anti-interference. |
| E19 | Current detection fault | <ul style="list-style-type: none"> ● Abnormal motor cable or motor insulation. | <ul style="list-style-type: none"> ● Remove motor cables to check. ● Contact us. |
| E20 | Motor autotuning fault | <ul style="list-style-type: none"> ● Motor capacity does not match with the VFD capacity. This fault may occur if the capacity difference exceeds five power classes. ● Incorrect motor parameter setting. ● The parameters gained from autotuning deviate sharply from the standard parameters. ● Autotuning timeout. ● Pulse current setting is too large. | <ul style="list-style-type: none"> ● Change the VFD model, or adopt V/F mode for control ● Check motor wiring, motor type, and parameter settings. ● Empty the motor load and re-perform autotuning. ● Check whether the upper limit frequency is larger than 2/3 of the rated frequency. ● Decrease the pulse current setting properly. |
| E21 | EEPROM operation fault | <ul style="list-style-type: none"> ● Error in reading or writing control parameters ● EEPROM damaged. | <ul style="list-style-type: none"> ● Press STOP/RST to reset. ● Replace the control board. |
| E22 | PID feedback offline. | <ul style="list-style-type: none"> ● PID feedback offline. ● PID feedback source disappears. | <ul style="list-style-type: none"> ● Check PID feedback signal wires. ● Check PID feedback source. |
| E23 | Braking unit fault | <ul style="list-style-type: none"> ● Fault occurred to the braking circuit or the braking pipe is damaged. ● External braking resistor with small resistance. | <ul style="list-style-type: none"> ● Check the braking unit, and replace with new braking pipe ● Increase the braking resistance. |
| E24 | Running time reached | <ul style="list-style-type: none"> ● Actual VFD running time longer than internally set running time. | <ul style="list-style-type: none"> ● Contact us. |

| Fault code | Fault type | Possible cause | Solution |
|------------|-------------------------------|---|---|
| E25 | Electronic overload | <ul style="list-style-type: none"> ● The VFD reports the overload alarm according to the setting. | <ul style="list-style-type: none"> ● Check whether the overload alarm point is set properly. |
| E27 | Parameter upload error | <ul style="list-style-type: none"> ● Keypad cable connected improperly or disconnected. ● Keypad cable too long, causing strong interference. ● Keypad or mainboard communication circuit error. | <ul style="list-style-type: none"> ● Check the keypad cable and re-plug to determine whether a fault occurs. ● Check the surroundings to rule out interference source ● Replace the hardware and seek maintenance services. |
| E28 | Parameter download error | <ul style="list-style-type: none"> ● Keypad cable connected improperly or disconnected. ● Keypad cable too long, causing strong interference. ● Keypad data storage error | <ul style="list-style-type: none"> ● Check the surroundings to rule out interference source ● Replace the hardware and seek maintenance services. ● Check whether the version of the control board software of keypad backup parameter copy is the same as the version of the control board software of the VFD. |
| E30 | Ethernet communication fault | <ul style="list-style-type: none"> ● No data transmission between the communication card and the host controller (or PLC). | <ul style="list-style-type: none"> ● Check whether the communication card wiring is loose or dropped. |
| E32 | To-ground short-circuit fault | <ul style="list-style-type: none"> ● The output of the VFD is short circuited to the ground. ● Current detection circuit fault. ● Actual motor power setup deviates sharply from the VFD power. | <ul style="list-style-type: none"> ● Check whether the motor is short circuited to the ground and wiring is normal. ● Check whether the motor wiring is normal. ● Replace the main control board. ● Reset the motor parameters properly. |
| E34 | Speed deviation fault | <ul style="list-style-type: none"> ● Load too heavy or stalled. | <ul style="list-style-type: none"> ● Check for overload, increase speed deviation detection time, |

| Fault code | Fault type | Possible cause | Solution |
|------------|---|--|--|
| | | | or prolong ACC/DEC time. ● Check motor parameter settings and re-perform motor parameter autotuning. ● Check speed loop control parameter settings. |
| E35 | Mal-adjustment fault | <ul style="list-style-type: none"> ● Load exception. ● Incorrect SM parameter settings. ● Autotuned motor parameters are inaccurate. ● The VFD is not connected to the motor. ● Flux weakening application. | <ul style="list-style-type: none"> ● Check for overload or stalling. ● Check motor parameter and counter EMF settings. ● Re-perform motor parameter autotuning. ● Increase the maladjustment detection time. ● Adjust flux weakening coefficient and current loop parameters. |
| E36 | Underload fault | <ul style="list-style-type: none"> ● The VFD reports the underload alarm according to the setting. | <ul style="list-style-type: none"> ● Check the load and overload alarm thresholds. |
| E40 | Safe torque off | <ul style="list-style-type: none"> ● Safe torque off function is enabled by external forces. | - |
| E41 | Safety circuit exception of STO channel 1 | <ul style="list-style-type: none"> ● The wiring of STO is improper ● Fault occurred to external switch of STO. | <ul style="list-style-type: none"> ● Check whether terminal wiring of STO is proper and firm enough. ● Check whether the external switch of STO can work properly |
| E42 | Safety circuit exception of STO channel 2 | <ul style="list-style-type: none"> ● Channel safety circuit hardware fault. | <ul style="list-style-type: none"> ● Replace the control board. <p>⚡ Note: Re-power on is required to remove the fault.</p> |
| E43 | Exception to both STO channel 1 and channel 2 | <ul style="list-style-type: none"> ● Hardware fault occurred to STO circuit. | <ul style="list-style-type: none"> ● Replace the control board. |
| E44 | STO safety code FLASH CRC check fault | <ul style="list-style-type: none"> ● Drive board fault. | <ul style="list-style-type: none"> ● Replace the drive board. |
| E57 | PROFINET | <ul style="list-style-type: none"> ● No data transmission | <ul style="list-style-type: none"> ● Check whether the |

| Fault code | Fault type | Possible cause | Solution |
|------------|--|---|--|
| | communication timeout | between the communication card and the host controller (or PLC). | communication card wiring is loose or dropped. |
| E59 | Motor overtemperature fault | <ul style="list-style-type: none"> ● Equipment or ambient temperature too high. ● AI/AO detected temperature inaccurate. ● DI4 input motor overtemperature signal. | <ul style="list-style-type: none"> ● Lower the equipment or ambient temperature. ● Replace the temperature measuring resistor. ● Check the external temperature measuring terminal signal. |
| E60 | Communication card identifying failure | <ul style="list-style-type: none"> ● There is data transmission in communication card interface, but the card type cannot be identified. | <ul style="list-style-type: none"> ● Check whether the expansion card in the slot is supported. ● Stabilize the expansion card interface after power-off, and check whether the fault persists at next power-on. ● Check whether the insertion port or card slot is damaged. If yes, replace the insertion port or card slot after power-off. |
| E63 | Communication card communication timeout fault | <ul style="list-style-type: none"> ● No data transmission in the communication card interface. | |
| E66 | EtherCAT communication timeout | <ul style="list-style-type: none"> ● No data transmission between the communication card and the host controller (or PLC). | <ul style="list-style-type: none"> ● Check whether the communication card wiring is loose or dropped. |
| E92 | AI1 disconnection | <ul style="list-style-type: none"> ● AI1 input too low. ● AI1 wiring disconnected. | <ul style="list-style-type: none"> ● Connect a 5V or 10mA power source to check whether the input is normal. ● Check the wiring or replace the cable. |
| E93 | AI2 disconnection | <ul style="list-style-type: none"> ● AI2 input too low. ● AI2 wiring disconnected. | |
| E94 | AI3 disconnection | <ul style="list-style-type: none"> ● AI3 input too low. ● AI3 wiring disconnected. | |
| E95 | EtherNet IP communication timeout | <ul style="list-style-type: none"> ● No data transmission between the communication card and the host controller (or PLC). | <ul style="list-style-type: none"> ● Check whether the communication card wiring is loose or dropped. |
| E96 | No upgrade | <ul style="list-style-type: none"> ● Upgrade bootloader | <ul style="list-style-type: none"> ● Contact us. |

| Fault code | Fault type | Possible cause | Solution |
|------------|--------------------------------|---|---|
| | bootloader | missing. | |
| E587 | Dual CPU communication fault 1 | <ul style="list-style-type: none"> ● Dual CPU communication fault. | <ul style="list-style-type: none"> ● Contact us. |
| E588 | Dual CPU communication fault 2 | | |

8.2.2 Other status

| Display code | Status type | Possible cause | Solution |
|--------------|----------------------|--|----------------------------|
| PoFF | System power failure | The system is powered off or the bus voltage is too low. | Check the grid conditions. |

8.3 Analysis on common faults

8.3.1 Motor fails to work

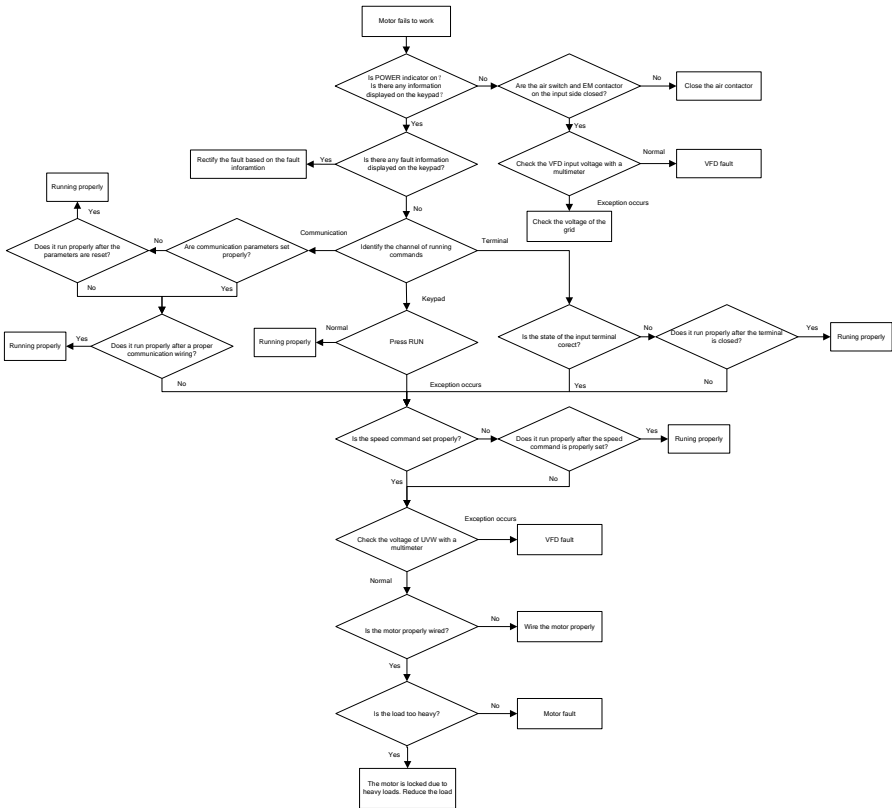

8.3.2 Motor vibrates

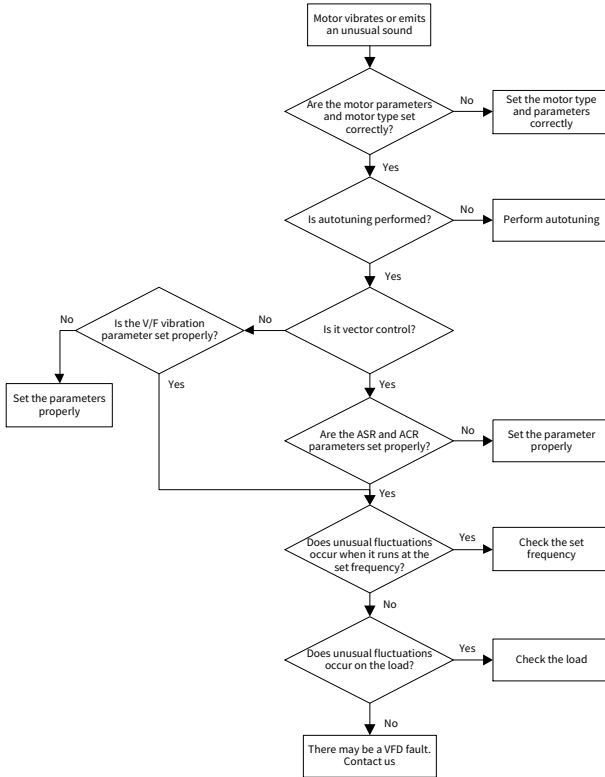

8.3.3 Overvoltage



8.3.4 Undervoltage

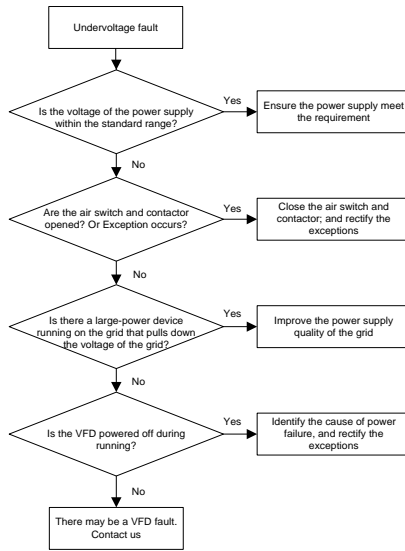

8.3.5 Overcurrent

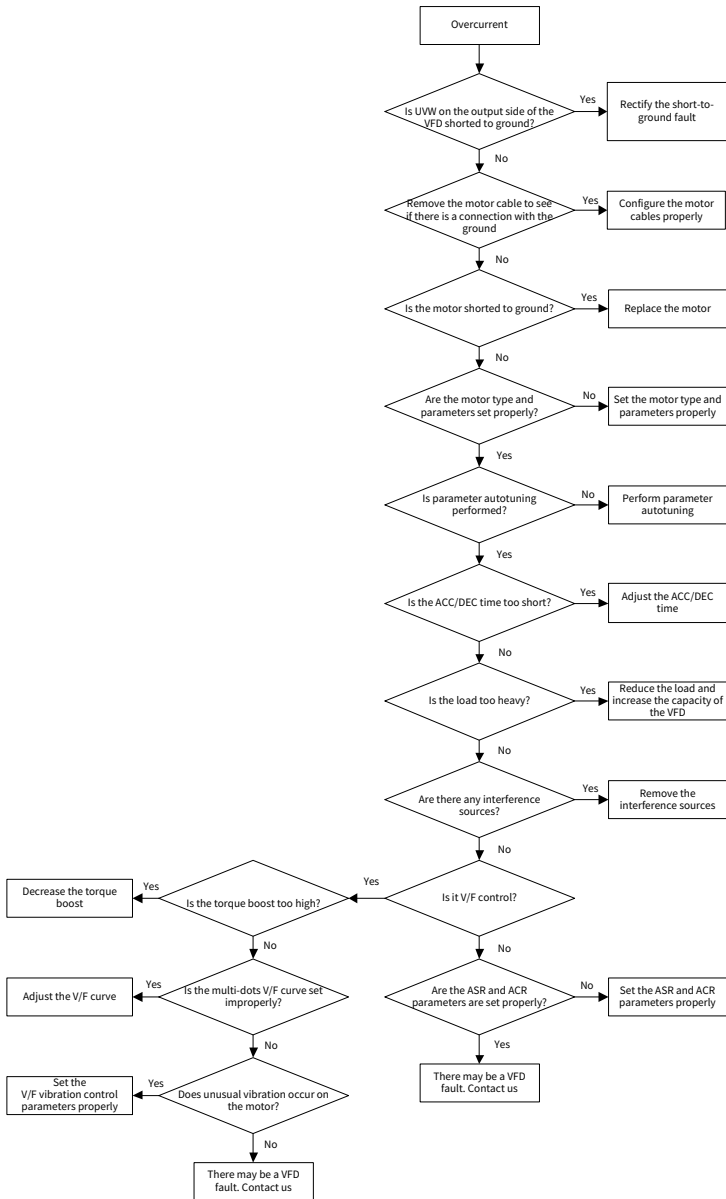

8.3.6 Motor overheating

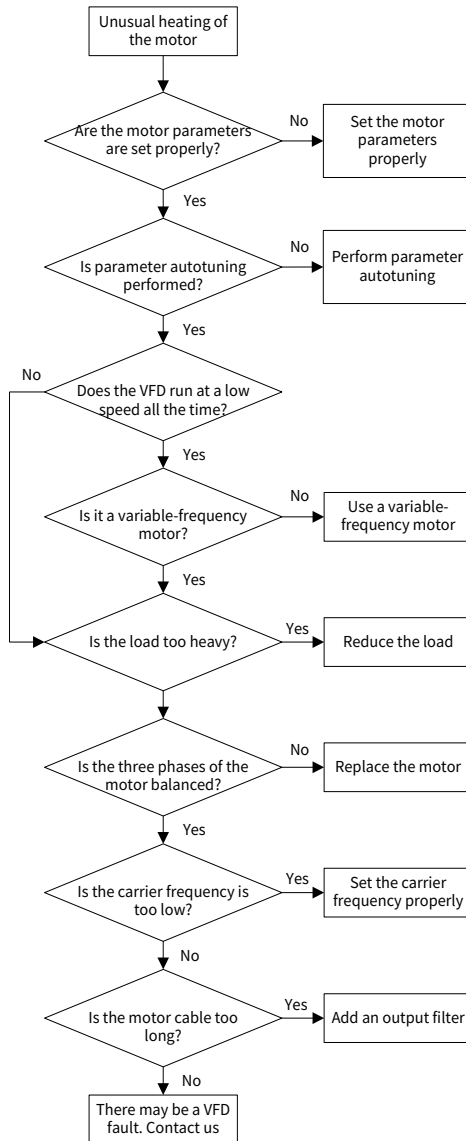

8.3.7 VFD overheating

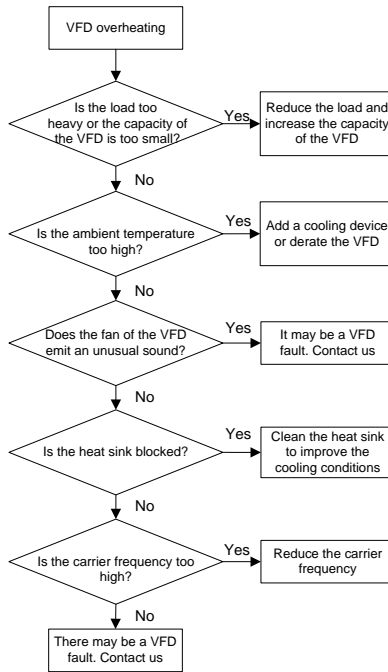

8.3.8 Motor stalls during ACC

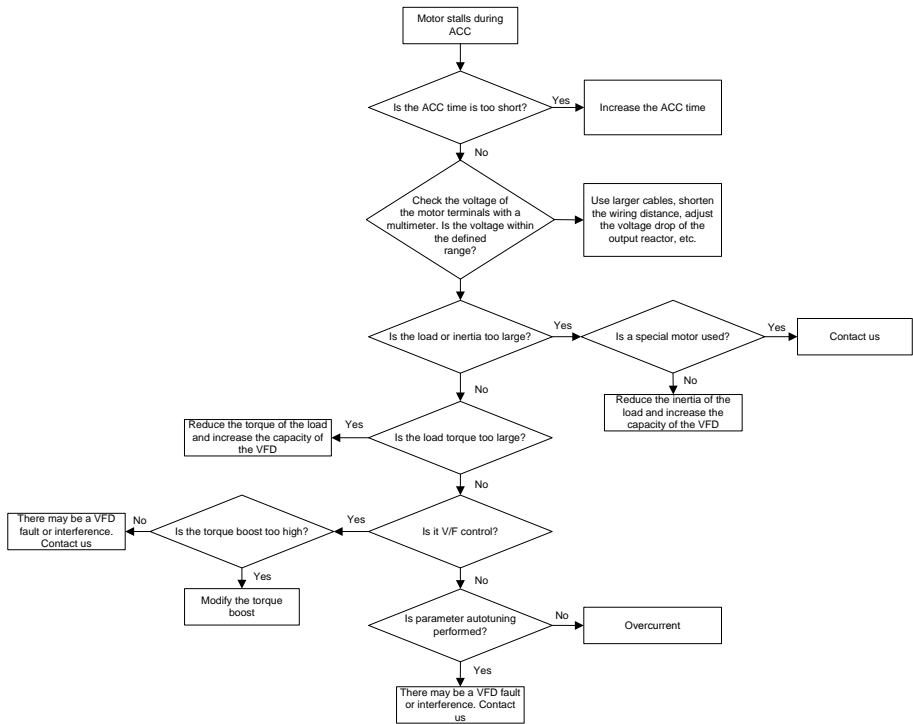

8.4 Countermeasures on common interference

8.4.1 Interference problems of meter switch and sensors

| Symptom | Solution |
|---|--|
| The upper or lower limit is wrongly displayed, for example, 999 or -999. | <ul style="list-style-type: none"> Check and ensure that the sensor feedback cable is 20cm or farther away from the motor cable. Check and ensure that the ground wire of the motor is connected to the PE terminal of the VFD (if the ground wire of the motor has been connected to the ground block of the VFD, you need to use a multimeter to measure and ensure that the resistance between the ground block and PE terminal is lower than 1.5 Ω). At the same time, you need to fasten the EMC AC screw and EMC DC screw/clip on the VFD. |
| The display of values jumps (usually occurring on pressure transmitters). | |
| The display of values is stable, but there is a large deviation, for example, the | |

| Symptom | Solution |
|--|--|
| temperature is dozens of degrees higher than the common temperature (usually occurring on thermocouples). | <ul style="list-style-type: none"> ● Try to add a safety capacitor of 0.1μF to the signal end of the feedback signal terminal of the sensor. ● Try to add a safety capacitor of 0.1μF to the power end of the sensor meter (pay attention to the voltage of the power supply and the voltage endurance of the capacitor). ● For interference when connecting the VFD analog output (AO1) terminal to a meter: If AO1 uses 0–20mA current signal, add a capacitor of 0.47μF between the AO1 and GND terminals; if AO1 uses 0–10V voltage signal, add a capacitor of 0.1μF between the AO1 and GND terminals. ● The signal cable needs to use the shielded cable, and the shield layer must be grounded reliably to the PE or GND. |
| A signal collected by a sensor is not displayed but functions as a drive system running feedback signal. For example, the VFD is expected to decelerate when the upper pressure limit of the compressor is reached, but in actual running, it starts to decelerate before the upper pressure limit is reached. | |
| All kinds of meters (such as frequency meter and current meter) connected to the VFD AO terminal (AO1) display very inaccurate values. | |
| Proximity switches are used in the system. After the VFD is started, the indicator of a proximity switch flickers, and the output level flips. | |

Note:

- When a decoupling capacitor is required, add it to the terminal of the device connected to the sensor. For example, if a thermocouple is to transmit signals of 0 to 20 mA to a temperature meter, the capacitor needs to be added on the terminal of the temperature meter.; if an electronic ruler is to transmit signals of 0 to 30 V to a PLC signal terminal, the capacitor needs to be added on the terminal of the PLC.

- If a large number of meters or sensors are disturbed, it is recommended that you configure an external C2 filter on the VFD input power end. For details, see section E.3.2 Filter.

8.4.2 Interference on RS485 communication

| Symptom | Solution | |
|--|---|--|
| Check whether the RS485 communication bus is disconnected or in poor contact. | <ul style="list-style-type: none"> ● Arrange the communication cables and motor cables in different cable trays. ● In multi-VFD application scenarios, adopt the chrysanthemum connection mode to connect the communication cables between VFDs, which can improve the anti-interference capability. ● In multi-VFD application scenarios, check and ensure that the driving capacity of the master is sufficient. ● In the connection of multiple VFDs, you need to configure one 120 Ω terminal resistor on each end. ● Check and ensure that the ground wire of the motor is connected to the PE terminal of the VFD (if the ground wire of the motor has been connected to the ground block of the VFD, you need to use a multimeter to measure and ensure that the resistance between the ground block and PE terminal is lower than 1.5 Ω). At the same time, you need to fasten the EMC AC screw and EMC DC screw/clip on the VFD. ● Do not connect the VFD and motor to the same ground terminal as the host controller (such as the PLC, HMI, and touch screen). It is recommended that you connect the VFD and motor to the power ground, and connect the host controller separately to a ground stud. ● Try to short the signal reference ground terminal (GND) of the VFD with that of the host controller to ensure that ground potential of the communication chip on the control board of the VFD is consistent with that of the communication chip of the host controller. ● Try to short GND of the VFD to its ground terminal (PE). ● Try to add a safety capacitor of 0.1μF at the power supply end of the host controller (PLC, HMI, or touch screen). Alternatively, use a magnet ring (Fe-based nanocrystalline magnet rings are recommended). Pass the L/N cable or +/- cable of the host controller power supply through the | |
| Check whether the two ends of line A or B are connected reversely. | | |
| Check whether the communication protocol of the VFD is consistent with that of the upper computer. Check whether the communication protocol (such as the baud rate, data bits, and check bit) of the VFD is consistent with that of the host computer. | | |

| Symptom | Solution |
|---------|--|
| | magnet ring in the same direction and wind around the magnet ring for 8 turns. |

8.4.3 Failure to stop and indicator shimmering due to motor cable coupling

| Symptom | Solution |
|--|--|
| <p>Failure to stop In a VFD system where a DI terminal is used to control the start and stop, the motor cable and control cable are arranged in the same cable tray. After the system is started properly, the DI terminal cannot be used to stop the system.</p> <p>Indicator shimmering After the VFD is started, the relay indicator, power distribution box indicator, PLC indicator, and indication buzzer shimmer, blink, or emit unusual sounds unexpectedly.</p> | <ul style="list-style-type: none"> ● Check and ensure that the exception signal cable is arranged 20 cm or farther away from the motor cable. ● Add a safety capacitor of 0.1μF between the digital input (DI) terminal and the COM terminal. ● Connect the digital input (DI) terminal that controls the start and stop to other idle digital input terminals in parallel. For example, if DI1 is used to control the start and stop and DI4 is idle, you can try to short connect DI1 to DI4. |

 **Note:** If the controller (such as PLC) in the system controls more than five VFDs at the same time through digital input terminals, this scheme is not applicable.

8.4.4 Leakage current and interference on RCD

■ **Working principle**

VFDs output high-frequency PWM voltage to drive motors. In this process, the distributed capacitance between the internal IGBT of a VFD and the heat sink and that between the stator and rotor of a motor may inevitably cause the VFD to generate high-frequency leakage current to the ground. A residual current operated protective device (RCD) is used to detect the power-frequency leakage current when a grounding fault occurs on a circuit. The application of a VFD may cause misoperation of a RCD.

■ **Rules for selecting RCDs**

1. VFD systems are special. In these systems, it is required that the rated residual current of common RCDs at all levels is larger than 200 mA, and the VFDs are grounded reliably.
2. For RCDs, the time limit of an action needs to be longer than that of a next action, and the time difference between two actions need to be longer than 20ms, for example, 1s, 0.5s, or 0.2s.
3. For circuits in VFD systems, electromagnetic RCDs are recommended.
Electromagnetic RCDs have strong anti-interference capability, and thus can prevent the impact of high-frequency leakage current.

| Electronic RCD | Electromagnetic RCD |
|--|--|
| Low cost, high sensitivity, small in volume, susceptible to voltage fluctuation of the grid and ambient temperature, and weak anti-interference capability | Requiring highly sensitive, accurate, and stable zero-phase sequence current transformer, using permalloy high-permeability materials, complex process, high cost, not susceptible to voltage fluctuation of the power supply and ambient temperature, strong anti-interference capability |

| Symptom | Solution |
|--|--|
| RCD misoperation at the transient VFD power-on | <ul style="list-style-type: none"> ● Solution to RCD misoperation (handling the VFD) <ul style="list-style-type: none"> ➢ Try to remove the EMC AC screw and EMC DC screw/clip from the VFD. ➢ Try to decrease the carrier frequency to 1.5kHz (P00.14=1.5). ➢ Try to modify the modulation method to "Switch from SVPWM to DPWM" (P08.42=00). ● Solution to RCD misoperation (handling the system power distribution) <ul style="list-style-type: none"> ➢ Check and ensure that the power cable is not soaking in water. ➢ Check and ensure that cables are not damaged or spliced. ➢ Check and ensure that no secondary grounding is performed on the neutral wire. ➢ Check and ensure that the main power cable terminal is in good contact with the air switch or contactor (all screws are tightened). ➢ Check 1PH powered devices, and ensure that no earth wires are used as neutral wires by these devices. |
| RCD misoperation after VFD running | |

| Symptom | Solution |
|---------|--|
| | <ul style="list-style-type: none"> ➤ Do not use shielded cables as VFD power cables and motor cables. |

8.4.5 Live device housing

■ Live device housing description

After the VFD is started, there is sensible voltage on the housing, and you may feel an electric shock when touching the housing. The chassis, however, is not live (or the voltage is far lower than the human safety voltage) when the VFD is powered on but not running.

| Symptom | Solution |
|---------------------|---|
| Live device housing | <ul style="list-style-type: none"> ● If there is power distribution grounding or ground stud on the site, ground the VFD cabinet housing through the power ground or stud. ● If there is no grounding on the site, you need to connect the motor housing to the VFD grounding terminal PE, and ensure that the VFD EMC AC screw and EMC DC screw/clip have been fastened. |

9 Inspection and maintenance

9.1 Daily inspection and regular maintenance

The VFD internal components will become aging due to the influence of environmental temperature, humidity, dust, vibration and other factors, which causes the potential failure or shortens the service life. Therefore, to extend the VFD service life and prevent safety hazards, daily inspection and regular maintenance are required.

| Check category | Content | Method |
|--|--|--|
| Daily inspection: Recommended on each day. | | |
| Ambient environment | Whether the ambient temperature, humidity, vibration, dust, gas, and oil are too great, and whether there is condensation or water droplets inside and outside the machine | Visual inspection and instrument measurement |
| | Whether there are foreign matters, such as tools, or dangerous substances placed nearby | Visual inspection |
| Power supply voltage | Whether the voltage between the main circuit and control circuit is normal | Multimeter or voltage meter |
| Keypad | Whether display is clear | Visual inspection |
| | Whether some characters or fields are displayed incompletely | Visual inspection |
| Fan | Whether it runs normally | Visual inspection |
| Load | Whether the motor is overloaded or overheating, or it sounds abnormally. | Visual inspection |
| Regular maintenance: Recommended on a quarterly basis, especially in harsh environments such as with dust, oil, or corrosive gases. Before regular maintenance, cut off the power and wait at least 15 min. | | |
| Complete machine | Whether the bolts become loose or come off | Visual inspection |
| | Whether the machine is deformed, cracked, or damaged, or the color changes due to overheating and aging | Visual inspection |
| | Whether much dirt or dust is attached | Visual inspection |
| | Whether there is abnormal sound or vibration, odor, discoloration (transformer, reactor and fan) | Auditory, olfactory, and visual inspection |
| Motor | Whether the installation is secure, motor insulation is normal, and the fan runs properly | Instrument or visual inspection |

| Check category | Content | Method |
|---------------------------|---|--|
| Cable | Whether there is discoloration, deformation, or damage | Visual inspection |
| | Whether the cable connectors or bolts become loose | Visual inspection |
| Connection terminal | Whether there is overheating or damage | Visual inspection |
| Electrolytic capacitor | Whether there is electrolyte leakage, discoloration, cracks, and housing expansion | Visual inspection |
| | Whether the safety valve is exposed outside | Visual inspection |
| External braking resistor | Whether there is displacement caused due to overheating | Olfactory and visual inspection |
| | Whether aging, skin breakage, or wire damage occurs to the resistor cable | Visual inspection, or measuring with a multimeter after removing one cable end |
| Relay | Whether there is vibration sound during running | Auditory inspection |
| Control PCB and connector | Whether the screws and connectors become loose | Screw them up. |
| | Whether there is unusual smell or discoloration | Olfactory and visual inspection |
| | Whether there is corrosion or rust stains | Visual inspection |
| Ventilation duct | Whether there are foreign matters blocking or attached to the cooling fan, air inlets, or air outlets | Visual inspection |

For more details about maintenance, contact the local INVT office, or visit our website www.invt.com, and choose **Support > Services**.

9.2 Cooling fan replacement

The wearing part of VFD is the cooling fan, of which the service life is closely related to the running environment and maintenance condition.

■ Possible damage cause

Bearing wear, blade aging, water, oil, dust and other environmental factors may cause circuit board damage.

■ Cooling fan replacement procedure

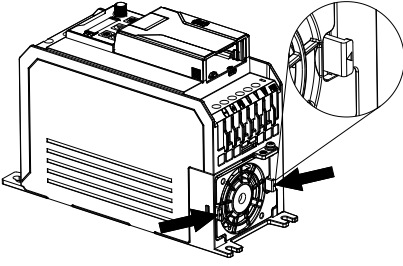
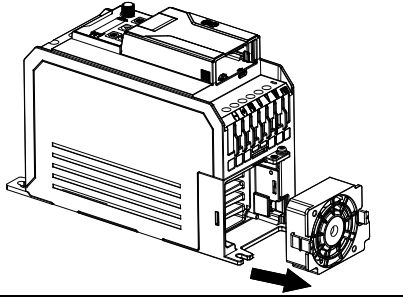
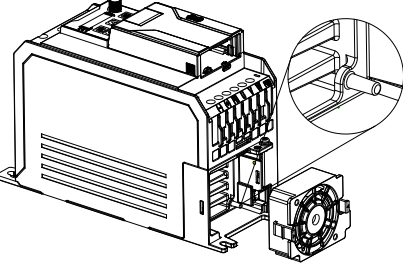
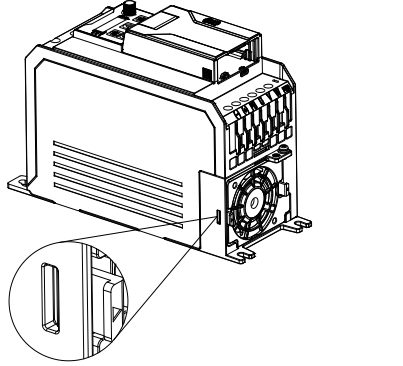
| Disassembling a fan | |
|---|---|
| <p>Step 1 Press the snaps on both sides of the fan with hands.</p>  | <p>Step 2 Pull out the fan outward at the same time.</p>  |
| Assembling a fan | |
| <p>Step 1 Align the two fixing holes on the fan with the positioning post.</p>  | <p>Step 2 Push in the fan until you hear a clicking sound.</p>  |

Note: Before disassembling or installing the VFD, stop the VFD, cut off the power, and wait at least 5 minutes.

9.3 Reforming

If the VFD has been left unused for a long time, you need to follow the instructions to reform the DC bus electrolytic capacitor before using it. The storage time is calculated from the date the VFD is delivered. For detailed operation, contact us.

| Storage time | Operation principle |
|------------------|--|
| Less than 1 year | No charging operation is required. |
| 1 to 2 years | Before the first run, apply the voltage of one class lower than the VFD voltage class to the VFD for 1 hour. |
| 2 to 3 years | Use a voltage controlled power supply to charge the VFD: |

| Storage time | Operation principle |
|-------------------|---|
| | <ul style="list-style-type: none"> ● Charge the VFD at 25% of the rated voltage for 30 minutes, ● and then charge it at 50% of the rated voltage for 30 minutes, ● at 75% for another 30 minutes, ● and finally charge it at 100% of the rated voltage for 30 minutes. |
| More than 3 years | Use a voltage controlled power supply to charge the VFD: <ul style="list-style-type: none"> ● Charge the VFD at 25% of the rated voltage for 2 hours, ● and then charge it at 50% of the rated voltage for 2 hours, ● at 75% for another 2 hours, ● and finally charge it at 100% of the rated voltage for 2 hours. |

The method for using a voltage controlled power supply to charge the VFD is described as follows:

The selection of a voltage controlled power supply depends on the power supply of the VFD. For VFDs with an incoming voltage of 1PH/3PH 230 V AC, you can use a 230 V AC/2 A voltage regulator. Both 1PH and 3PH VFDs can be charged with a 1PH voltage controlled power supply (connect L+ to L1, and N to L2 or L3). All the DC bus capacitors share one rectifier, and therefore they are all charged.

For VFDs of a high voltage class, ensure that the voltage requirement (for example, 380 V) is met during charging. Capacitor charging requires little current, and therefore you can use a small-capacity power supply (2 A is sufficient).

The method for using a resistor (incandescent lamp) to charge the drive is described as follows:

If you directly connect the drive device to a power supply to charge the DC bus capacitor, it needs to be charged for a minimum of 60 minutes. The charging operation must be performed at a normal indoor temperature without load, and you must connect a resistor in series mode in the 3PH circuit of the power supply.

For a 380 V drive device, use a resistor of 1 kΩ/100W. If the voltage of the power supply is no higher than 380 V, you can also use an incandescent lamp of 100W. If an incandescent lamp is used, it may go off or the light may become very weak.

Figure 9-1 380V drive device charging circuit example

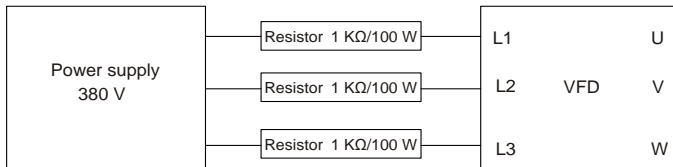

Appendix A Expansion card

The VFD supports the use of communication expansion cards to enhance communication capabilities. The following table lists the supported expansion cards. The expansion cards are optional and must be purchased separately.

A.1 Model definition

$$\frac{EC}{①} - \frac{TX}{②} \frac{149}{③}$$

Table A-1 Expansion card model description

| No. | Field | Description |
|-----|---------------------|--|
| ① | Product category | EC: Expansion card |
| ② | Board card category | TX: communication extension card |
| ③ | Product code | 149: PROFINET/EtherCAT/EtherNet IP/Modbus TCP four-in-one expansion card |

Figure A-1 Expansion card physical image

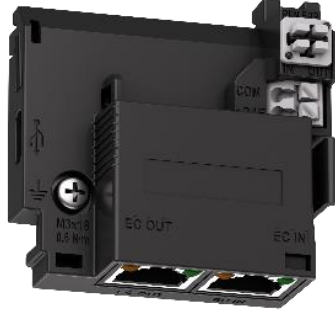

A.2 Specifications

Table A-2 Expansion card specifications

| Parameter | Specifications |
|-----------------------|--------------------------|
| Working temperature | -10~+50°C |
| Storage temperature | -20~60°C |
| Relative humidity | 5%~95% (No condensation) |
| Operating environment | No corrosive gas |

| Parameter | Specifications |
|--------------------|--|
| Mounting method | Fixed with snap-fits and screws |
| Cooling method | Natural air cooling |
| Communication rate | 100M bit/s |
| Network topology | Supports both linear and star network topologies, with certain protocols also accommodating ring network topology. |

Figure A-2 Expansion card drawing

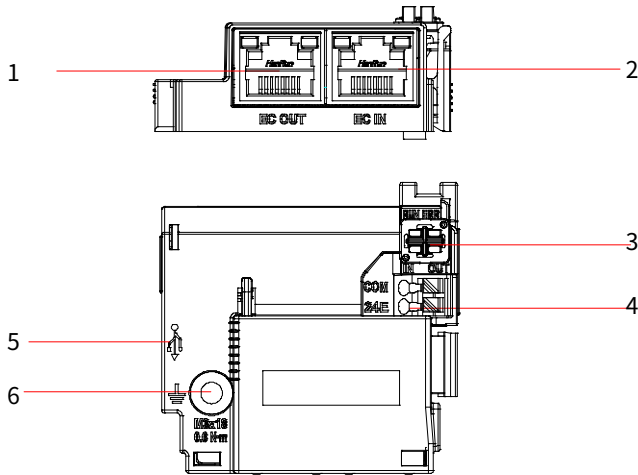

Table A-3 Product component description

| No. | Name | Description |
|-----|-----------------------------|--|
| 1 | Communication port (EC OUT) | Supported bus types: PROFINET, EtherCAT, EtherNet IP, and Modbus TCP EtherCAT can be only used in the OUT port, while the other three protocols do not distinguish the direction. |
| 2 | Communication port (EC IN) | Supported bus types: PROFINET, EtherCAT, EtherNet IP, and Modbus TCP EtherCAT can be only used in the IN port, while the other three protocols do not distinguish the direction. |
| 3 | Indicator | For details, see section A.4 Indicator. |
| 4 | +24E | An external 24V connection can be used for communication debugging. |
| | COM | |
| 5 | Type-C | Manufacturer reserved |
| 6 | Fixing hole | Used for expansion card and control board installation and fixing. |

A.3 Protocol parameter

Table A-4 Expansion card protocol selection

| Function code | Protocol | Description |
|---------------|--|---------------------------|
| P24.00 | 0-15 0: PROFINET 1: EtherCAT 2: Reserved 3: EtherNet IP 4: Modbus TCP 5: EtherNet UDP 6: PROFINET+EtherNet UDP 7: EtherCAT+EtherNet UDP 8-14: Reserved 15: No communication expansion card | The factory setting is 0. |

Table A-5 Protocol description

| Protocol | Description |
|-------------|--|
| PROFINET | <ol style="list-style-type: none"> 1. Supports the PROFINET protocol, accommodating PROFINET IO devices, medium redundancy protocol (MRP), and system redundancy protocol (S2). Equipped with the slave station GSDML configuration file, it can communicate with Siemens PLC and other master stations. 2. Enables basic operations on VFDs, such as reading and writing process values, reading status values, and reading/writing function codes. This communication card supports up to 32 IOs. 3. Applicable to linear, star, and ring network topologies. |
| EtherCAT | <ol style="list-style-type: none"> 1. Supports the CiA301 and CiA402 CoE protocols. Configured with a slave station XML configuration file, it can communicate with Beckhoff PLC, INVT AX controllers, and other master stations. 2. Supports PDO and SDO services, manufacturer-defined object dictionaries, and SDO reading/writing of VFD function codes, meeting the EtherCAT compliance testing certification requirements within the factory. 3. Applicable to linear, star, and ring network topologies. 4. Equipped with two RJ45 ports, designated for IN and OUT directions. |
| Ethernet IP | <ol style="list-style-type: none"> 1. Supports ODVA standards and DLR ring protocol. When configured with a slave station EDS configuration file, it can communicate with Rockwell PLC and other master stations. 2. Enables basic operations on VFDs, such as reading and writing process |

| Protocol | Description |
|------------|---|
| | values, reading status values, and reading/writing function codes. This communication card supports up to 32 IOs. 3. Applicable to linear, star, and ring network topologies. |
| Modbus TCP | 1. Supports the Modbus TCP protocol. A Modbus TCP slave station can communicate with multiple master stations simultaneously. It can communicate with Schneider PLC, INVT AX controllers, and other master stations. 2. Enables basic operations on VFDs, such as reading and writing process values, reading status values, and reading/writing function codes. 3. Applicable to linear and star network topologies. |

A.4 Indicator

Table A-6 PROFINET communication indicators

| Indicator | Color | Definition | Function |
|-----------|-------|---|--|
| RUN | Green | Steady on | Communication established successfully, with normal IO data exchange. |
| | | Blinking (on for 500ms, off for 500ms) | Communication established successfully, but without valid IO data exchange. |
| | | Blinking (on for 100ms, off for 100ms) | In the communication configuration phase. For example, when DCP configuration commands are triggered, it will blink simultaneously with the ERR indicator. |
| | | Steady off | The communication between the communication card and PLC is not in Online state. |
| IN(HOST) | Green | Steady on | The communication card is in the process of handshaking with the VFD. |
| | | Blinking (on for 500ms, off for 500ms) | The communication card and VFD communicate normally.  Note: After the handshaking is completed, it should blink regardless of whether there is data transmission between the communication card and the main control board. |

| Indicator | Color | Definition | Function |
|-----------|-------|---|--|
| | | Steady off | The communication card is in the initialization or parameter configuration phase. |
| OUT(DATA) | Green | Steady off | No data update or abnormal update between the communication card and main control board. |
| | | Blinking (on for 500ms, off for 500ms) | The data update between the communication card and main control board is normal. |
| ERR | Red | Steady off | No fault |
| | | Blinking (on for 100ms, off for 100ms) | Communication establishment is abnormal. |

Table A-7 EtherCAT communication indicators

| Indicator | Color | Definition | Function |
|--------------|-------|--|--|
| RUN | Green | Steady off | In Init state. |
| | | Blinking (on for 200ms, off for 200ms) | In PreOP state. |
| | | Single flash (on for 200ms, off for 1s) | In SafeOP state. |
| | | Steady on | In OP state. |
| IN(L/A IN) | Green | Steady on | IN Link established, without data transmission. |
| | | Blinking (on for 50ms, off for 50ms) | IN Link established, with data transmission. |
| | | Steady off | IN LINK not established. |
| OUT(L/A OUT) | Green | Steady on | OUT Link established, without data transmission. |
| | | Blinking (on for 50ms, off for 50ms) | OUT Link established, with data transmission. |
| | | Steady off | OUT LINK not established. |
| ERR | Red | Steady off | No fault |
| | | Blinking (on for 200ms, off for 200ms) | The Init/Preop fault occurred. |
| | | Single flash | The Safeop fault occurred. |

| Indicator | Color | Definition | Function |
|-----------|-------|----------------------------|------------------------|
| | | (on for 200ms, off for 1s) | |
| | | Steady on | The OP fault occurred. |

Table A-8 EtherNet IP communication indicators

| Indicator | Color | Definition | Function |
|-----------|-------|---|--|
| RUN | Green | Steady on | The communication between the communication card and the PLC is online, and data exchange is allowed. |
| | | Blinking (on for 500ms, off for 500ms) | Abnormal setting of the IP address for either the communication card or the PLC. |
| | | Steady off | The communication between the communication card and PLC is not in Online state. |
| IN(HOST) | Green | Steady on | The communication card is in the process of handshaking with the VFD. |
| | | Blinking (on for 500ms, off for 500ms) | The communication card and VFD communicate normally.  Note: After the handshaking is completed, it should blink regardless of whether there is data transmission between the communication card and the main control board. |
| | | Steady off | The communication card is in the initialization or parameter configuration phase. |
| OUT(DATA) | Green | Steady off | No data update or abnormal update between the communication card and main control board. |
| | | Blinking (on for 500ms, off for 500ms) | The data update between the communication card and main control board is normal. |
| ERR | Red | Steady off | No fault |
| | | Blinking (on for 500ms, off for 500ms) | Incorrect PLC configuration. |
| | | Blinking (on for 250ms, off for 250ms) | The communication card failed to send data to the PLC. |

| Indicator | Color | Definition | Function |
|-----------|-------|---|---|
| | | 250ms) | |
| | | Blinking (on for 125ms, off for 125ms) | The connection between the communication card and PLC timed out. |
| | | Steady on | Failed to set up data communication between the communication card and PLC. |

Table A-9 Modbus TCP communication indicators

| Indicator | Color | Definition | Function |
|-----------|-------|---|--|
| RUN | Green | Steady on | The communication between the communication card and the PLC is online, and data exchange is allowed. |
| | | Blinking (on for 500ms, off for 500ms) | Abnormal setting of the IP address for either the communication card or the PLC. |
| | | Steady off | The communication between the communication card and PLC is not in Online state. |
| IN(HOST) | Green | Steady on | The communication card is in the process of handshaking with the VFD. |
| | | Blinking (on for 500ms, off for 500ms) | The communication card and VFD communicate normally.  Note: After the handshaking is completed, it should blink regardless of whether there is data transmission between the communication card and the main control board. |
| | | Steady off | The communication card is in the initialization or parameter configuration phase. |
| OUT(DATA) | Green | Steady off | No data update or abnormal update between the communication card and main control board. |
| | | Blinking (on for 500ms, off for 500ms) | The data update between the communication card and main control board is normal. |
| ERR | Red | Steady on | The communication between the |

| Indicator | Color | Definition | Function |
|-----------|-------|---|--|
| | | | communication card and PLC is offline. |
| | | Blinking (on for 500ms, off for 500ms) | An attempt to operate an unsupported CMD control word instruction or PR function code value. |
| | | Blinking (on for 62.5ms, off for 62.5ms) | An attempt to operate on a non-existent node address. |
| | | Steady off | The communication between the communication card and PLC is normal. |

A.5 Expansion card installation and wiring

A.5.1 Expansion card installation procedure

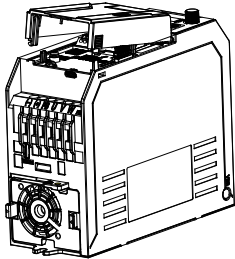
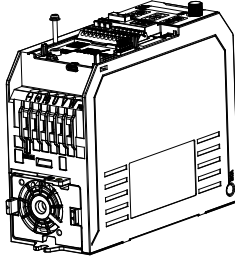
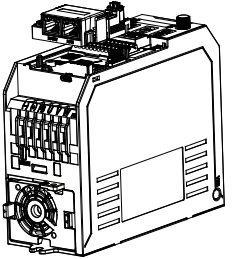
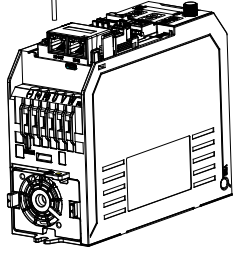
| | |
|--|---|
| <p>Step 1 Release the cover snap and remove the cover.</p>  | <p>Step 2 Remove the control board grounding screw.</p>  |
| <p>Step 3 Align and insert the expansion card.</p>  | <p>Step 4 Insert the control board grounding screw.</p>  |
| <p>Step 5 Install the cover.</p> | |

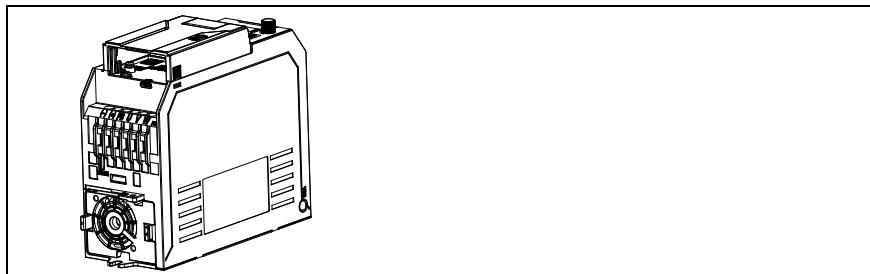

A.5.2 Expansion card wiring

Figure A-3 Product network port structure



Table A-10 RJ45 network port functions

| No. | Port | Description |
|-----|------|----------------|
| 1 | TX+ | Transmit Data+ |
| 2 | TX - | Transmit Data- |
| 3 | RX+ | Receive Data+ |
| 4 | n/c | Not connected |
| 5 | n/c | Not connected |
| 6 | RX - | Receive Data- |
| 7 | n/c | Not connected |
| 8 | n/c | Not connected |

The communication card uses standard RJ45 interfaces, and its electrical connections are shown in the following figures.

Note: It is recommended to use double-twisted shielded Category 5e Ethernet cables, with crystal heads equipped with iron shells to meet the grounding shield protection.

Figure A-4 Linear network topology electrical connection

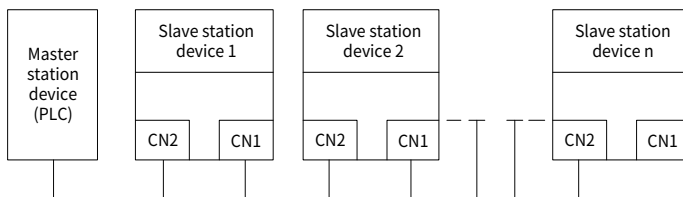
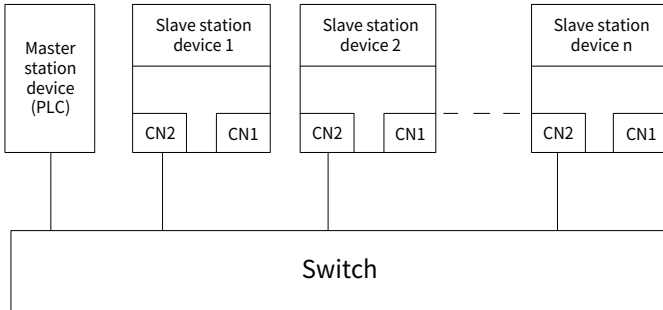
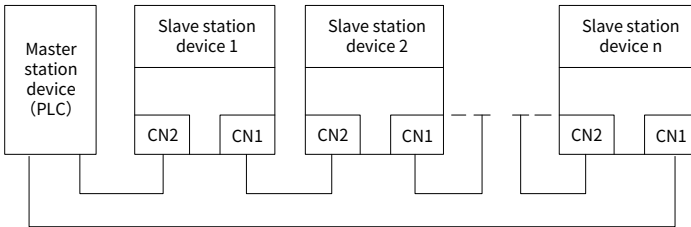

Figure A-5 Star network topology electrical connection



Note: For the star network topology, you need to prepare switches.

Figure A-6 Ring network topology electrical connection



A.6 Commissioning

Figure A-7 Expansion card commissioning flowchart

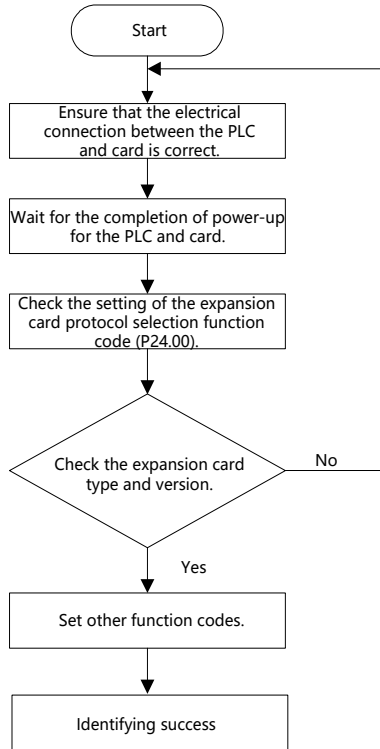

When 14.71 is 0 (defined in decimal), the VFD control word (CW) definitions are as follows:

Table A-11 Goodrive28 series VFD CWs in decimal

| Bit | Name | Value | Description |
|-----|-------------------------------------|-------|--------------------------|
| 0-7 | Communication-based control command | 1 | FWD run |
| | | 2 | REV run |
| | | 3 | Jog forward |
| | | 4 | Jog reversely |
| | | 5 | Stop |
| | | 6 | Coast to stop |
| | | 7 | Fault reset |
| | | 8 | Stop jogging |
| | | 9 | Stop in emergency manner |

| Bit | Name | Value | Description |
|------|----------------------------|-------|--|
| 8 | WRITE ENABLE | 1 | Enable read and write (PKW1–PKW4) |
| 9–10 | Motor group setting | 00 | MOTOR GROUP 1 SELECTION (Select motor 1) |
| | | 01 | MOTOR GROUP 2 SELECTION (Select motor 2) |
| 11 | Control mode selection | 1 | Torque/Speed control selection enabling |
| | | 0 | Do not select |
| 12 | ELECTRIC CONSUMPTION CLEAR | 1 | Enabling the function for resetting power consumption to zero |
| | | 0 | Disabling the function for resetting power consumption to zero |
| 13 | PRE-EXCIATION | 1 | Enable pre-exciting |
| | | 0 | Disable pre-exciting |
| 14 | DC BRAKE | 1 | Enabling DC braking |
| | | 0 | Disabling DC braking |
| 15 | HEARTBEAT REF | 1 | Enable heartbeat |
| | | 0 | Disable heartbeat |

When P14.71 is 1 (defined in binary), the VFD control CW definitions are as follows:

Table A-12 Goodrive28 series VFD CWs in binary

| Bit | Name | Description | Priority |
|-----|-----------------------------------|---|----------|
| 0 | Forward running | 0: Decelerate to stop 1: Run forward | 1 |
| 1 | Reverse running | 0: Decelerate to stop 1: Run reversely | 2 |
| 2 | Fault reset | 0: None 1: Fault reset | 3 |
| 3 | Coast to stop | 0: None 1: Coast to stop | 4 |
| 4 | Forward jogging | 0: None 1: Forward jogging | 5 |
| 5 | Reverse jogging | 0: None 1: Reverse jogging | 6 |
| 6 | Stop jogging | 0: None 1: Stop jogging | 7 |
| 7 | - | Reserved | - |
| 8 | Enable read and write (PKW1–PKW4) | 0: None 1: Enable read and write | - |

| Bit | Name | Description | Priority |
|-------|--------------------------|------------------------------|------------------|
| 9 | - | Reserved | - |
| 10 | Stop in emergency manner | 0: None 1: Emergency stop | 0 (Top priority) |
| 11-15 | Reserved | - | - |

When P14.71 is 0 (defined in decimal), the VFD status word (SW) definitions are as follows:

Table A-13 Goodrive28 series VFD SWs in decimal

| Bit | Name | Value | Description |
|-------|---|-------|-----------------------------|
| 0-7 | Running status | 1 | Running forward |
| | | 2 | Running reversely |
| | | 3 | Stopped |
| | | 4 | In fault |
| | | 5 | VFD in POFF state |
| 8 | Bus voltage established | 1 | Ready to run |
| | | 0 | Not ready to run |
| 9-10 | Motor group feedback | 0 | Feedback from motor 1 |
| | | 1 | Feedback from motor 2 |
| 11 | Motor type feedback | 1 | Synchronous motor (SM) |
| | | 0 | Asynchronous motor (AM) |
| 12 | Overload pre-alarm feedback | 1 | Overload pre-alarm |
| | | 0 | No overload pre-alarm |
| 13-14 | RUN/STOP MODE (Running mode selection) | 0 | Keypad-based control |
| | | 1 | Terminal-based control |
| | | 2 | Communication-based control |
| | | 3 | Reserved |
| 15 | HEARTBEAT FEEDBACK (Heartbeat feedback) | 1 | Heartbeat feedback |
| | | 0 | No heartbeat feedback |

When P14.71 is 1 (defined in binary), the VFD SW definitions are as follows:

Table A-14 Goodrive28 series VFD SWs in binary

| Bit | Name | Description | Priority |
|-----|-----------------|---------------------------------|----------|
| 0 | Forward running | 0: None 1: Running forward | 1 |
| 1 | Reverse running | 0: None 1: Running reversely | 2 |
| 2 | Stop | 0: None 1: Stopped | 3 |

| Bit | Name | Description | Priority |
|------|--------------|---|----------|
| 3 | Fault | 0: None 1: VFD in fault | 4 |
| 4 | POFF | 0: None 1: VFD in POFF state | 5 |
| 5 | Pre-exciting | 0: None 1: VFD in pre-exciting state | 6 |
| 6-15 | Reserved | - | - |

Appendix B Technical data

If the ambient temperature at the VFD installation site exceeds 50°C, the VFD installation site altitude exceeds 1000m, a ventilation cover is used, or the carrier frequency is higher than the recommended (see P00.14), the VFD needs to be derated. In environments where multiple derating factors must be considered (such as high altitude and high temperature), the derating effects are cumulative.

B.1 Derating due to temperature

The temperate range is -10°C–50°C. When the heavy load temperature is higher than 50°C, or the light load temperature is higher than 40°C, the rated output current of each model is derated as follows.

Table B-1 Derating due to ambient temperature

| Product model | Frame | Relationship between derating factor and temperature |
|---------------|-------|---|
| GD28-0R2G-S2 | A | <p>Heavy-load derating coefficient</p> <p>Ambient temperature</p> |
| GD28-0R4G-S2 | | |
| GD28-0R7G-S2 | | |
| GD28-0R2G-2 | | |
| GD28-0R4G-2 | | |
| GD28-0R7G-2 | | |
| GD28-0R4G-4 | | |
| GD28-0R7G-4 | | |
| GD28-1R1G-4 | | |
| GD28-1R1G-S2 | B | <p>Heavy-load derating coefficient</p> <p>Ambient temperature</p> |
| GD28-1R5G-S2 | | |
| GD28-2R2G-S2 | | |
| GD28-1R1G-2 | | |
| GD28-1R5G-2 | | |
| GD28-2R2G-2 | | |
| GD28-1R5G-4 | | |

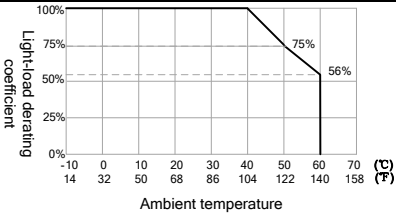
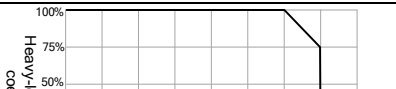
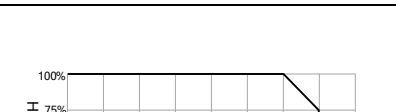
| Product model | Frame | Relationship between derating factor and temperature |
|---------------|-------|--|
| GD28-2R2G-4 | |  <p>Ambient temperature</p> |
| GD28-003G-4 | | |
| GD28-004G-4 | | |
| GD28-004G-S2 | C |  <p>Ambient temperature</p> |
| GD28-004G-2 | | |
| GD28-5R5G-2 | | |
| GD28-5R5G-4 | | |
| GD28-7R5G-4 | | |
| GD28-7R5G-2 | D |  <p>Ambient temperature</p> |
| GD28-011G-2 | | |
| GD28-011G-4 | | |
| GD28-015G-4 | | |

| Product model | Frame | Relationship between derating factor and temperature |
|---------------|-------|--|
| GD28-015G-2 | E | <p>The figure contains two line graphs. The top graph is titled 'Heavy-load derating coefficient' and the bottom graph is titled 'Light-load derating coefficient'. Both graphs have 'Ambient temperature' on the x-axis, ranging from -10 to 70 °C (14 to 158 °F). The y-axis represents the derating coefficient from 0% to 100%. In both graphs, the derating coefficient is 100% from -10°C to 40°C. From 40°C to 60°C, it decreases linearly to 80%. At 60°C, there is a vertical drop to 0% at 70°C.</p> |
| GD28-018G-4 | | |
| GD28-022G-4 | | |

Note: It is not recommended to use the VFD at an environment with the temperature higher than 60°C. If you do, you shall be held accountable for the consequences caused.

B.2 Derating due to altitude

When the VFD installation site altitude is lower than 1000m, the VFD can run at the rated power. When the altitude exceeds 1000m, derate by 1% for every increase of 100m. When the altitude exceeds 3000m, consult our local dealer or office for details.

B.3 Derating due to carrier frequency

The carrier frequency of the VFD varies with power class. The VFD rated power is defined based on the carrier frequency factory setting.

| Model | Current coefficients at different carrier frequencies | | | | |
|-------------------------|---|------|------|-------|-------|
| | 4kHz | 6kHz | 8kHz | 10kHz | 12kHz |
| AC 1PH 200V–240V | | | | | |
| GD28-0R2G-S2 | 1 | 1 | 1 | 0.9 | 0.85 |
| GD28-0R4G-S2 | 1 | 1 | 1 | 0.9 | 0.85 |
| GD28-0R7G-S2 | 1 | 1 | 1 | 0.9 | 0.85 |
| GD28-1R1G-S2 | 1 | 1 | 1 | 0.9 | 0.85 |
| GD28-1R5G-S2 | 1 | 1 | 1 | 0.9 | 0.85 |
| GD28-2R2G-S2 | 1 | 1 | 1 | 0.9 | 0.85 |
| GD28-004G-S2 | 1 | 1 | 1 | 0.9 | 0.85 |
| AC 3PH 200V–240V | | | | | |
| GD28-0R2G-2 | 1 | 1 | 1 | 0.9 | 0.81 |

| Model | Current coefficients at different carrier frequencies | | | | |
|-------------------------|---|------|------|-------|-------|
| | 4kHz | 6kHz | 8kHz | 10kHz | 12kHz |
| GD28-0R4G-2 | 1 | 1 | 1 | 0.91 | 0.84 |
| GD28-0R7G-2 | 1 | 1 | 1 | 0.94 | 0.89 |
| GD28-1R1G-2 | 1 | 1 | 1 | 0.95 | 0.91 |
| GD28-1R5G-2 | 1 | 1 | 1 | 0.96 | 0.93 |
| GD28-2R2G-2 | 1 | 1 | 1 | 0.98 | 0.96 |
| GD28-5R5G-2 | 1 | 1 | 1 | 0.93 | 0.86 |
| GD28-7R5G-2 | 1 | 1 | 1 | 0.93 | 0.87 |
| GD28-011G-2 | 1 | 1 | 1 | 0.93 | 0.88 |
| GD28-015G-2 | 1 | 1 | 1 | 0.91 | 0.84 |
| AC 3PH 380V-480V | | | | | |
| GD28-0R4G-4 | 1 | 0.79 | 0.65 | 0.54 | 0.46 |
| GD28-0R7G-4 | 1 | 0.81 | 0.68 | 0.58 | 0.50 |
| GD28-1R1G-4 | 1 | 0.82 | 0.69 | 0.59 | 0.52 |
| GD28-1R5G-4 | 1 | 0.85 | 0.73 | 0.64 | 0.57 |
| GD28-2R2G-4 | 1 | 0.85 | 0.73 | 0.64 | 0.56 |
| GD28-003G-4 | 1 | 0.87 | 0.76 | 0.67 | 0.60 |
| GD28-004G-4 | 1 | 0.85 | 0.72 | 0.63 | 0.55 |
| GD28-5R5G-4 | 1 | 0.87 | 0.77 | 0.68 | 0.61 |
| GD28-7R5G-4 | 1 | 0.87 | 0.77 | 0.68 | 0.60 |
| GD28-011G-4 | 1 | 0.87 | 0.77 | 0.68 | 0.61 |
| GD28-015G-4 | 1 | 0.88 | 0.79 | 0.71 | 0.64 |
| GD28-018G-4 | 1 | 0.87 | 0.77 | 0.68 | 0.61 |
| GD28-022G-4 | 1 | 0.84 | 0.72 | 0.62 | 0.55 |

B.4 Grid specifications

| | |
|------------------------|---|
| Grid voltage | AC 1PH 200V(-15%)–240V(+10%) AC 3PH 200V(-15%)–240V(+10%) AC 3PH 380V(-15%)–480V(+10%) |
| Short-circuit capacity | According to the definition in IEC 61439-1, the maximum allowable short-circuit current at the incoming end is 100 kA. Therefore, the VFD is applicable to scenarios where the transmitted current in the circuit is no larger than 100kA when the VFD runs at the maximum rated voltage. |
| Frequency | 50/60Hz±5%, with a maximum change rate of 20%/s |

B.5 Motor connection data

| | |
|--------------------------|--|
| Motor type | Asynchronous induction motor or permanent-magnet synchronous motor |
| Voltage | 0–U1 (motor rated voltage), 3PH symmetrical, Umax (VFD rated voltage) at the field-weakening point |
| Short-circuit protection | The motor output short-circuit protection meets the requirements of IEC 61800-5-1. |
| Frequency | 0–599Hz |
| Frequency resolution | 0.01Hz |
| Current | See section 2.3 Product ratings. |
| Power limit | 1.5 times the motor rated power |
| Field-weakening point | 10–599Hz |
| Carrier frequency | 4, 8, 12, or 15kHz |

B.5.1 Motor cable length for normal operation

Motor cable lengths for normal operation are listed in the following table.

| Frame | Max. motor cable length |
|-------|-------------------------|
| A | 50m |
| B | 75m |
| C | 150m |
| D | 200m |
| E | 200m |

Note: When the motor cable is too long, electrical resonance may be caused due to the influence of distributed capacitance. This may cause motor insulation damage or generate large leakage current, causing device overcurrent protection. You must configure the AC output reactor nearby the VFD when the cable length is longer than the corresponding value in the preceding table.

B.5.2 Motor cable length for EMC

The standard models meet the EMC requirements of IEC/EN61800-3, and the maximum shielded motor cable lengths used at a 4kHz switching carrier frequency are as follows.

| Frame | Max. motor cable length | | |
|-------------------------|--|-----|---------------------|
| | Standard model (including built-in filter and EMC grounding screw) | | External filter |
| | C2 | C3 | C2 |
| AC 1PH 200V-240V | | | |
| A | 5m | 15m | 50m |
| B | 5m | 15m | 50m |
| C | 5m | 15m | 50m |
| AC 3PH 200V-240V | | | |
| A | - | 15m | 50m |
| B | - | 15m | 20/50m ¹ |
| C | - | 15m | 20/50m ² |
| D | - | 15m | 50m |
| E | - | 15m | 50m |
| AC 3PH 380V-480V | | | |
| A | - | 15m | 50m |
| B | - | 15m | 20/50m ¹ |
| C | - | 15m | 20/50m ² |
| D | - | 15m | 50m |
| E | - | 15m | 50m |

 **Note:**

- "1": For a frame-B 3PH model, with only an external input filter, it meets the C2 20m motor cable length requirement; when both input and output filters are added, it meets the C2 50m motor cable length requirement.
- "2": For a frame-C 3PH model, with an external input filter and a carrier frequency of 2kHz, it meets the C2 20m motor cable length requirement; with both input and output filters and a carrier frequency of 4kHz, it meets the C2 50m motor cable length requirement.
- For details about product frames, see section 2.5 Product dimensions and weight.
- For details about C2 filters, see section E.3.2 Filter.

Appendix C Application standards

C.1 List of application standards

The following table describes the application standards that VFDs comply with.

| | |
|------------------|---|
| EN/ISO 13849-1 | Safety of machinery—Safety related parts of control systems—Part 1: General principles for design |
| EN/ISO 13849-2 | Safety of machinery—Safety related parts of control systems—Part 2: Verification |
| IEC/EN 60204-1 | Safety of machinery—Electrical equipment of machines. Part 1: General requirements |
| IEC/EN 62061 | Safety of machinery—Safety-related functional safety of electrical, electronic, and programmable electronic control systems |
| IEC 61800-3 | Adjustable speed electrical power drive systems—Part 3: EMC requirements and specific test methods |
| IEC/EN 61800-5-1 | Adjustable speed electrical power drive systems—Part 5-1: Safety requirements—Electrical, thermal and energy |
| IEC/EN 61800-5-2 | Adjustable speed electrical power drive systems—Part 5-2: Safety requirements—Function |

C.2 CE/TUV/UL/CCS certification

The CE mark affixed to the VFD indicates that the VFD is CE-compliant, meeting the regulations of the European low-voltage directive (2014/35/EU) and EMC directive (2014/30/EU).

The TUV mark affixed to the VFD indicates that the VFD is TUV-compliant. TUV certification includes TUV-MARK, TUV-CE, TUV-CB, GS, and VDE certifications, which has high authority and recognition in the field of electronic appliances and components.

The UL mark affixed to the VFD indicates that the VFD has passed UL certification. UL certification is a voluntary certification in the United States (but mandatory in some states), and products that have passed the certification meet the relevant UL standard requirements can enter the US market.

The CCS mark affixed to the VFD indicates that the VFD is CCS-compliant. CCS is the ship inspection certification of China Classification Society. The certified products can be used on ships.

Note: The nameplate of a product shows the actual certification result.

C.3 EMC compliance declaration

The VFD complies with the EMC product standards EN 61800-3:2004 + A1:2012; EN IEC 61800-3: 2018; EN IEC 61800-3: 2023, meeting the requirements for categories C2 and C3 (motor cable length limit for ensuring EMC compliance) as defined in the standard.

C.4 EMC product standard

The VFD is compliant with EN 61800-3:2004 + A1:2012; EN IEC 61800-3: 2018; EN IEC 61800-3: 2023.

EMC is short for electromagnetic compatibility, which refers to the ability of a device or system to function properly in its electromagnetic environment and not constitute an unbearable electromagnetic disturbance to anything in that environment.

Application environment categories:

First environment: Civilian environment, including application scenarios where the VFD is directly connected without intermediate transformer to a low-voltage power supply network which supplies residential buildings.

🔗**Note:** The product may generate radio interference in the First environment. In addition to the CE compliance requirements mentioned in this chapter, you should take necessary measures to prevent interference when needed.

Second environment: All locations outside a residential area.

VFDs of C1: Rated voltage lower than 1000V, applied to the first environment.

VFDs of C2: Rated voltage lower than 1000V, neither a non-plug, socket, nor mobile devices, and must be installed and commissioned by a professional person when used in the first environment.

🔗**Note:** The product may generate radio interference in some environments, you need to take measures to reduce the interference.

VFDs of C3: Rated voltage lower than 1000 V, applied to the second environment. They cannot be applied to the first environment.

🔗**Note:** VFDs of C3 cannot be applied to civilian low-voltage public grids. When applied to such grids, the VFD may generate radio frequency electromagnetic interference.

VFDs of C4: VFD of rated voltage higher than 1000V, or rated current higher or equal to 400A, applied to complex systems in the second environment.

🔗**Note:** The EMC standard IEC/EN 61800-3 no longer restricts the power distribution of the VFD, but defines the use, installation, and commissioning of the VFD. Specialized personnel or organizations must have the necessary skills (including the EMC-related knowledge) for installing and/or performing commissioning on the electrical drive systems.

Appendix D Dimension drawings

D.1 Keypad structure

Figure D-1 LED keypad structure (unit: mm)

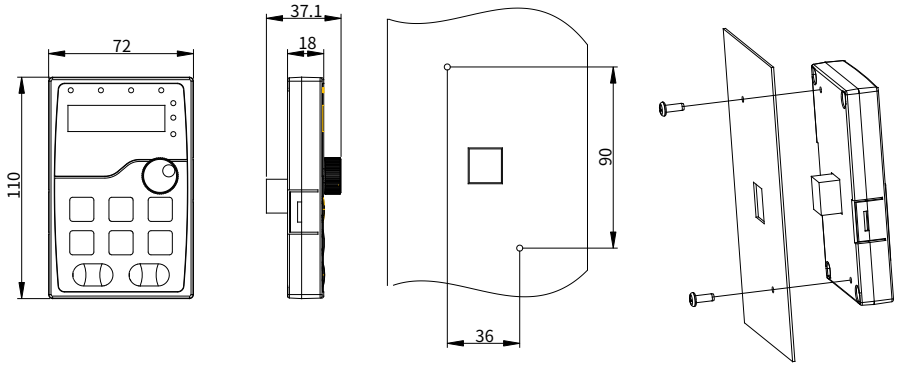
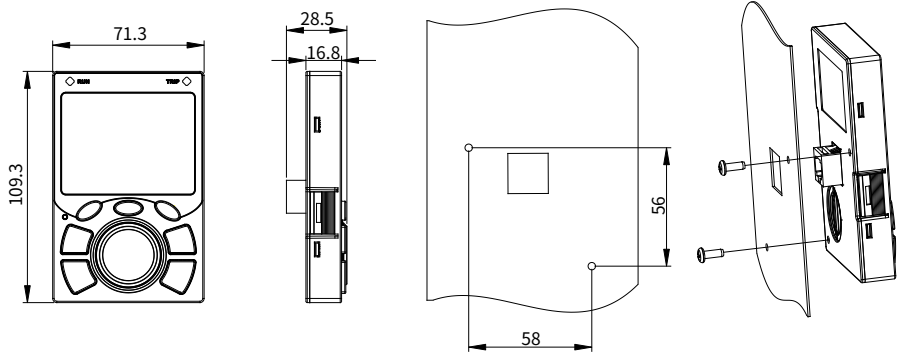

Figure D-2 LCD keypad structure (unit: mm)



D.2 Product outline dimensions

Figure D-3 Dimensions and hole positions for VFDs in frames A and B

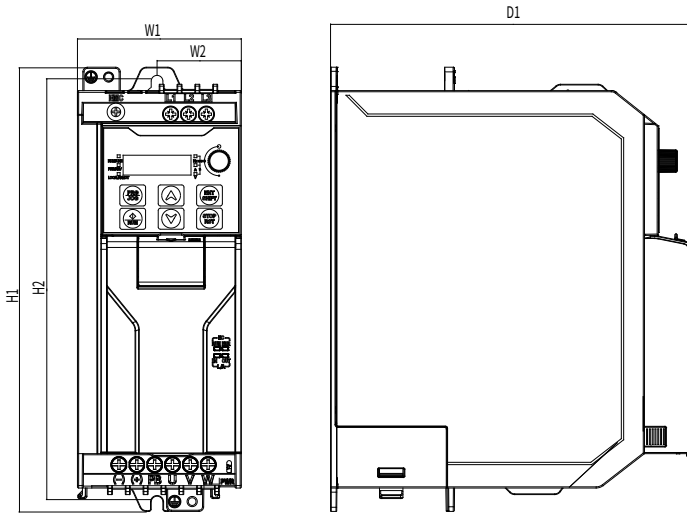

Table D-1 Dimensions and hole positions for VFDs in frames A and B

| Product model | Frame | Outline dimensions (mm) | | | Mounting hole distance (mm) | | Mounting hole diameter (mm) |
|---------------|-------|-------------------------|-----|-----|-----------------------------|-----|-----------------------------|
| | | W1 | H1 | D1 | W2 | H2 | |
| GD28-0R4G-S2 | A | 60 | 190 | 155 | 36 | 180 | Ø5 |
| GD28-0R7G-S2 | | 60 | 190 | 155 | 36 | 180 | Ø5 |
| GD28-0R4G-2 | | 60 | 190 | 155 | 36 | 180 | Ø5 |
| GD28-0R7G-2 | | 60 | 190 | 155 | 36 | 180 | Ø5 |
| GD28-0R7G-4 | | 60 | 190 | 155 | 36 | 180 | Ø5 |
| GD28-1R5G-4 | | 60 | 190 | 155 | 36 | 180 | Ø5 |
| GD28-1R5G-S2 | B | 70 | 190 | 155 | 36 | 180 | Ø5 |
| GD28-2R2G-S2 | | 70 | 190 | 155 | 36 | 180 | Ø5 |
| GD28-1R5G-2 | | 70 | 190 | 155 | 36 | 180 | Ø5 |
| GD28-2R2G-2 | | 70 | 190 | 155 | 36 | 180 | Ø5 |
| GD28-2R2G-4 | | 70 | 190 | 155 | 36 | 180 | Ø5 |
| GD28-003G-4 | | 70 | 190 | 155 | 36 | 180 | Ø5 |
| GD28-004G-4 | | 70 | 190 | 155 | 36 | 180 | Ø5 |

Figure D-4 Dimensions and hole positions for VFDs in frame C

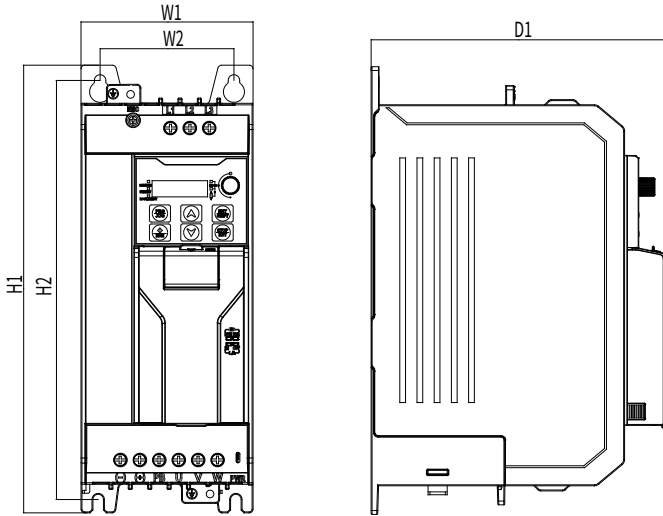

Table D-2 Dimensions and hole positions for VFDs in frame C

| Product model | Frame | Outline dimensions (mm) | | | Mounting hole distance (mm) | | Mounting hole diameter (mm) |
|---------------|-------|-------------------------|-----|-----|-----------------------------|-----|-----------------------------|
| | | W1 | H1 | D1 | W2 | H2 | |
| GD28-004G-2 | C | 90 | 235 | 155 | 70 | 220 | Ø6 |
| GD28-5R5G-4 | | 90 | 235 | 155 | 70 | 220 | Ø6 |
| GD28-7R5G-4 | | 90 | 235 | 155 | 70 | 220 | Ø6 |

Figure D-5 Dimensions and hole positions for VFDs in frame D

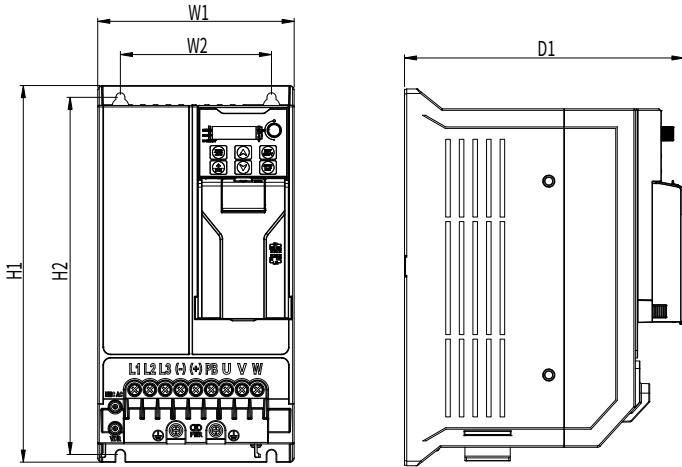

Table D-3 Dimensions and hole positions for VFDs in frame D

| Product model | Frame | Outline dimensions (mm) | | | Mounting hole distance (mm) | | Mounting hole diameter (mm) |
|---------------|-------|-------------------------|-----|-----|-----------------------------|-----|-----------------------------|
| | | W1 | H1 | D1 | W2 | H2 | |
| GD28-7R5G-2 | D | 130 | 250 | 185 | 100 | 237 | Ø 6 |
| GD28-011G-2 | | 130 | 250 | 185 | 100 | 237 | Ø 6 |
| GD28-011G-4 | | 130 | 250 | 185 | 100 | 237 | Ø 6 |
| GD28-015G-4 | | 130 | 250 | 185 | 100 | 237 | Ø 6 |

Figure D-6 Dimensions and hole positions for VFDs in frame E

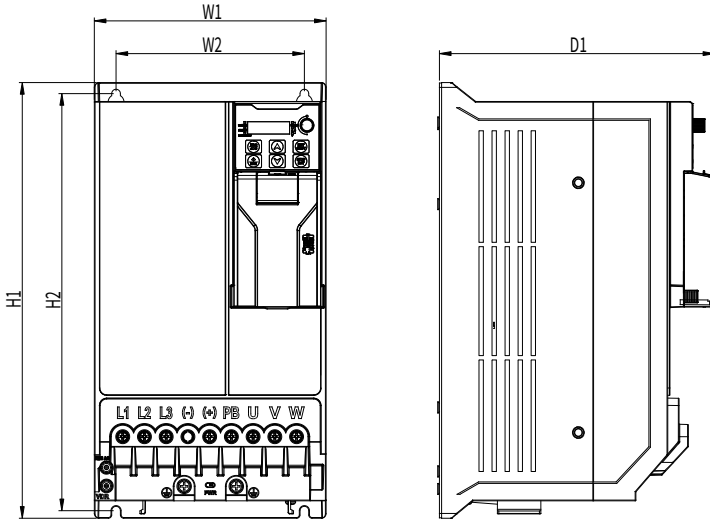

Table D-4 Dimensions and hole positions for VFDs in frame E

| Product model | Frame | Outline dimensions (mm) | | | Mounting hole distance (mm) | | Mounting hole diameter (mm) |
|---------------|-------|-------------------------|-----|-----|-----------------------------|-----|-----------------------------|
| | | W1 | H1 | D1 | W2 | H2 | |
| GD28-015G-2 | E | 160 | 300 | 190 | 130 | 287 | Ø 6 |
| GD28-018G-4 | | 160 | 300 | 190 | 130 | 287 | Ø 6 |
| GD28-022G-4 | | 160 | 300 | 190 | 130 | 287 | Ø 6 |

D.3 Flange mounting dimensions

Figure D-7 Dimensions and hole positions for VFDs in frame D or E

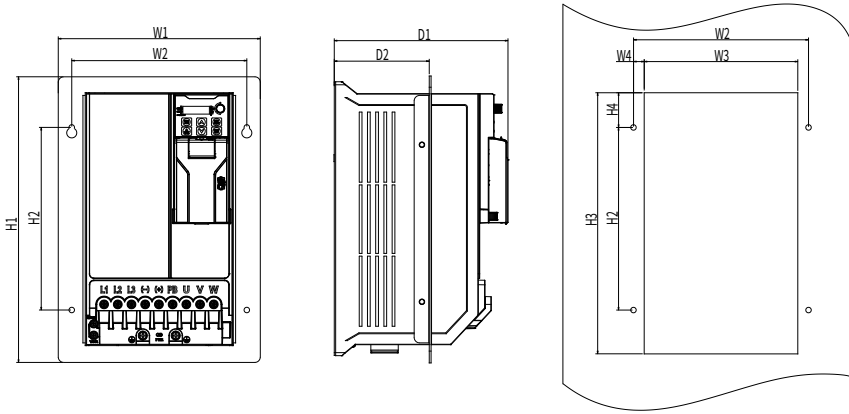

Table D-5 Flange mounting dimensions for VFDs in frame D or E (unit: mm)

| Product model | W1 | W2 | W3 | W4 | H1 | H2 | H3 | H4 | D1 | D2 | Hole diameter | Screw |
|---------------|-----|-----|-----|----|-----|-----|-----|----|-----|-----|---------------|-------|
| GD28-7R5G-2 | 190 | 170 | 150 | 10 | 275 | 170 | 252 | 50 | 185 | 105 | Ø6 | M5 |
| GD28-011G-2 | 190 | 170 | 150 | 10 | 275 | 170 | 252 | 50 | 185 | 105 | Ø6 | M5 |
| GD28-011G-4 | 190 | 170 | 150 | 10 | 275 | 170 | 252 | 50 | 185 | 105 | Ø6 | M5 |
| GD28-015G-4 | 190 | 170 | 150 | 10 | 275 | 170 | 252 | 50 | 185 | 105 | Ø6 | M5 |
| GD28-015G-2 | 220 | 200 | 180 | 10 | 325 | 200 | 302 | 50 | 190 | 105 | Ø6 | M5 |
| GD28-018G-4 | 220 | 200 | 180 | 10 | 325 | 200 | 302 | 50 | 190 | 105 | Ø6 | M5 |
| GD28-022G-4 | 220 | 200 | 180 | 10 | 325 | 200 | 302 | 50 | 190 | 105 | Ø6 | M5 |

Appendix E Peripheral accessories

E.1 Cable

Cables mainly include power cables and control cables. For the selection of cable types, see the following table.

| Cable type | | Symmetrical shielded cable | Four-core cable | Double-shielded twisted-pair cable | Single-shielded twisted-pair cable |
|---------------|------------------------------|----------------------------|-----------------|------------------------------------|------------------------------------|
| Power cable | Input power cable | ✓ | - | - | - |
| | Motor cable | ✓ | - | - | - |
| Control cable | Analog signal control cable | - | - | ✓ | - |
| | Digital signal control cable | - | - | ✓ | ✓ |

E.1.1 Power cable

Table E-1 Cable selection

| VFD model | L1, L2, L3/U, V, W, PB, (+), (-) | | PE | | Fastening torque (Nm) |
|-------------------------|---|---------------------------------------|---|---------------------------------------|-----------------------|
| | Recommended cable size (AWG/mm ²) | Recommended connection terminal model | Recommended cable size (AWG/mm ²) | Recommended connection terminal model | |
| AC 1PH 200V-240V | | | | | |
| GD28-0R2G-S2 | 15/1.5 | GTVE15010 | 15/1.5 | TVR2-4 | 0.8 |
| GD28-0R4G-S2 | 15/1.5 | GTVE15010 | 15/1.5 | TVR2-4 | 0.8 |
| GD28-0R7G-S2 | 15/1.5 | GTVE15010 | 15/1.5 | TVR2-4 | 0.8 |
| GD28-1R1G-S2 | 13/2.5 | GTVE25012 | 13/2.0 | TVR2-4 | 0.8 |
| GD28-1R5G-S2 | 11/4 | GTVE40012 | 11/4 | TVR3.5-4 | 0.8 |
| GD28-2R2G-S2 | 9/6 | GTVE60012 | 9/6 | TVR3.5-4 | 0.8 |
| GD28-004G-S2 | 7/10 | GTVE100012 | 7/10 | TNR8-5 | 1.2 |
| AC 3PH 200V-240V | | | | | |
| GD28-0R2G-2 | 15/1.5 | GTVE15010 | 15/1.5 | TVR2-4 | 0.8 |
| GD28-0R4G-2 | 15/1.5 | GTVE15010 | 15/1.5 | TVR2-4 | 0.8 |
| GD28-0R7G-2 | 15/1.5 | GTVE15010 | 15/1.5 | TVR2-4 | 0.8 |
| GD28-1R1G-2 | 15/1.5 | GTVE15010 | 15/1.5 | TVR2-4 | 0.8 |
| GD28-1R5G-2 | 13/2.5 | GTVE25012 | 13/2.5 | TVR2-4 | 0.8 |
| GD28-2R2G-2 | 11/4 | GTVE40012 | 11/4 | TVR3.5-4 | 0.8 |

| VFD model | L1, L2, L3/U, V, W, PB, (+), (-) | | PE | | Fastening torque (Nm) |
|-------------------------|---|---------------------------------------|---|---------------------------------------|-----------------------|
| | Recommended cable size (AWG/mm ²) | Recommended connection terminal model | Recommended cable size (AWG/mm ²) | Recommended connection terminal model | |
| GD28-004G-2 | 9/6 | GTVE60012 | 9/6 | TVR3.5-4 | 1.2 |
| GD28-5R5G-2 | 7/10 | GTVE100012 | 7/10 | TNR8-5 | 1.2 |
| GD28-7R5G-2 | 5/16 | GTVE160012 | 5/16 | TNR14-5 | 2 |
| GD28-011G-2 | 3/25 | GTVE250016 | 5/16 | TNR14-5 | 2 |
| GD28-015G-2 | 2/35 | GTVE350016 | 5/16 | TNR22-6 | 2 |
| AC 3PH 380V-480V | | | | | |
| GD28-0R4G-4 | 15/1.5 | GTVE15010 | 15/1.5 | TVR2-4 | 0.8 |
| GD28-0R7G-4 | 15/1.5 | GTVE15010 | 15/1.5 | TVR2-4 | 0.8 |
| GD28-1R1G-4 | 15/1.5 | GTVE15010 | 15/1.5 | TVR2-4 | 0.8 |
| GD28-1R5G-4 | 15/1.5 | GTVE15010 | 15/1.5 | TVR2-4 | 0.8 |
| GD28-2R2G-4 | 15/1.5 | GTVE15010 | 15/1.5 | TVR2-4 | 0.8 |
| GD28-003G-4 | 13/2.5 | GTVE25012 | 13/2.5 | TVR2-4 | 0.8 |
| GD28-004G-4 | 11/4 | GTVE40012 | 11/4 | TVR3.5-4 | 0.8 |
| GD28-5R5G-4 | 9/6 | GTVE60012 | 9/6 | TVR3.5-4 | 1.2 |
| GD28-7R5G-4 | 7/10 | GTVE100012 | 7/10 | TNR8-5 | 1.2 |
| GD28-011G-4 | 5/16 | GTVE160012 | 5/16 | TNR14-5 | 2 |
| GD28-015G-4 | 5/16 | GTVE60012 | 5/16 | TNR14-5 | 2 |
| GD28-018G-4 | 3/25 | GTVE250012 | 5/16 | TNR14-5 | 2 |
| GD28-022G-4 | 2/35 | GTVE350016 | 5/16 | TNR22-6 | 2 |

Note: The cables recommended for the main circuit can be used in scenarios where the ambient temperature is lower than 50°C, the wiring distance is shorter than 100m, and the current is the rated current.

■ Crimp terminal selection

Due to reasons such as longer cable length or laying, it is necessary to increase the cross-sectional area of the cable and replace the corresponding matching terminal blocks (wire lugs).

GTVE tubular pre-insulated terminal reference brand: Suzhou Yuanli

TVR circular pre-insulated terminal reference brand: Suzhou Yuanli

TNR circular bare terminal reference brand: Suzhou Yuanli

The terminal models vary by brand, and the manufacturer's model specifications shall prevail.

The terminals of DBV models are not recommended.

Figure E-1 GTVE tubular pre-insulated terminal appearance



Figure E-2 TVR circular pre-insulated terminal appearance



Figure E-3 TNR circular bare terminal appearance



E.1.2 Control cable

Control cables mainly include analog signal control cables and digital signal control cables. Analog signal control cables use twisted double shielded cables (Figure a), with a separate shielded twisted pair for each signal and different ground wires for different analog signals. For digital signals, a double-shielded cable is preferred, but single-shielded or unshielded twisted pairs can also be used (Figure b).

Figure E-4 Control cable routing

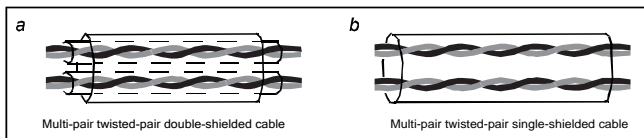

Note:

- Independent shielded cables must be used as analog signal cables and communication cables.
- The same cable cannot transmit 24V DC signals and 115/230V AC signals simultaneously.
- For frequency signals, only shielded cables can be used.

- A relay cable needs to carry the metal braided shield layer.
- For control cable wiring terminals, refer to the GTVE wiring terminal description in the wire lug model selection section.

E.2 Breaker, fuse, and electromagnetic contactor

The circuit breaker is mainly used to prevent electric shock accidents and short circuits to the ground that may cause leakage current fire. The electromagnetic contactor is mainly used to control the main circuit power on and off, which can effectively cut off the input power of the VFD in case of system failure to ensure safety.

Table E-2 Model selection of breaker, fuse, and electromagnetic contactor

| VFD model | Braker (A) | Fuse (A) | Contactor rated current (A) |
|-------------------------|------------|----------|-----------------------------|
| AC 1PH 200V-240V | | | |
| GD28-0R2G-S2 | 6 | 8 | 9 |
| GD28-0R4G-S2 | 10 | 16 | 9 |
| GD28-0R7G-S2 | 16 | 25 | 12 |
| GD28-1R1G-S2 | 20 | 25 | 18 |
| GD28-1R5G-S2 | 25 | 32 | 25 |
| GD28-2R2G-S2 | 32 | 40 | 32 |
| GD28-004G-S2 | 40 | 50 | 38 |
| AC 3PH 200V-240V | | | |
| GD28-0R2G-2 | 6 | 6 | 9 |
| GD28-0R4G-2 | 6 | 8 | 9 |
| GD28-0R7G-2 | 10 | 16 | 9 |
| GD28-1R1G-2 | 16 | 20 | 12 |
| GD28-1R5G-2 | 20 | 25 | 18 |
| GD28-2R2G-2 | 25 | 32 | 25 |
| GD28-004G-2 | 40 | 40 | 32 |
| GD28-5R5G-2 | 50 | 50 | 40 |
| GD28-7R5G-2 | 63 | 80 | 65 |
| GD28-011G-2 | 80 | 100 | 65 |
| GD28-015G-2 | 100 | 125 | 95 |
| AC 3PH 380V-480V | | | |
| GD28-0R4G-4 | 6 | 6 | 9 |
| GD28-0R7G-4 | 10 | 8 | 9 |
| GD28-1R1G-4 | 10 | 10 | 9 |
| GD28-1R5G-4 | 16 | 16 | 12 |

| VFD model | Braker (A) | Fuse (A) | Contactora rated current (A) |
|-------------|------------|----------|------------------------------|
| GD28-2R2G-4 | 16 | 16 | 12 |
| GD28-003G-4 | 20 | 25 | 18 |
| GD28-004G-4 | 20 | 25 | 18 |
| GD28-5R5G-4 | 32 | 40 | 32 |
| GD28-7R5G-4 | 40 | 50 | 32 |
| GD28-011G-4 | 50 | 63 | 50 |
| GD28-015G-4 | 63 | 80 | 65 |
| GD28-018G-4 | 80 | 100 | 65 |
| GD28-022G-4 | 100 | 125 | 95 |

 **Note:** The accessory specifications described in the preceding table are ideal values. You can select accessories based on the site conditions, but try not to use those with lower values.

E.3 Option

Reactors, filters, braking components, and mounting brackets are external accessories and need to be specifically specified when purchasing.

E.3.1 Reactor

An input reactor is used to improve the power factor on the input side of the VFD, and thus restrict high-order harmonic currents.

An output reactor is used to extend the effective transmission distance of the VFD and effectively suppress instantaneous high voltage generated when the IGBT module of the VFD switches.

Due to parasitic capacitance between the long cable and ground, the leakage current is large and the overcurrent protection of the VFD may be frequently triggered. To prevent this from happening and avoid damage to the motor insulator, compensation must be made by adding an output reactor. For the length of the cable between the VFD and the motor, see section B.5.1 Motor cable length for normal operation. If the length exceeds the limit, see the following table for selection; if the length exceeds twice the limit, consult us directly.

Table E-3 Reactor model selection

| VFD power | Input reactor | Output reactor |
|-------------------------|---------------|-----------------|
| AC 1PH 200V-240V | | |
| 0.2kW | - | GDL-OCL0005-4CU |
| 0.4kW | - | GDL-OCL0005-4CU |

| VFD power | Input reactor | Output reactor |
|-------------------------|-----------------|-----------------|
| 0.75kW | - | GDL-OCL0005-4CU |
| 1.1kW | - | GDL-OCL0010-4CU |
| 1.5kW | - | GDL-OCL0010-4CU |
| 2.2kW | - | GDL-OCL0014-4CU |
| 4kW | - | GDL-OCL0020-4CU |
| AC 3PH 200V-240V | | |
| 0.2kW | GDL-ACL0005-4CU | GDL-OCL0005-4CU |
| 0.4kW | GDL-ACL0006-4CU | GDL-OCL0005-4CU |
| 0.75kW | GDL-ACL0014-4CU | GDL-OCL0005-4CU |
| 1.1kW | GDL-ACL0014-4CU | GDL-OCL0010-4CU |
| 1.5kW | GDL-ACL0014-4CU | GDL-OCL0010-4CU |
| 2.2kW | GDL-ACL0014-4CU | GDL-OCL0020-4CU |
| 4kW | GDL-ACL0025-4CU | GDL-OCL0020-4CU |
| 5.5kW | GDL-ACL0032-4CU | GDL-OCL0032-4CU |
| 7.5kW | GDL-ACL0040-4CU | GDL-OCL0040-4CU |
| 11kW | GDL-ACL0051-4AL | GDL-OCL0050-4AL |
| 15kW | GDL-ACL0090-4AL | GDL-OCL0075-4AL |
| AC 3PH 380V-480V | | |
| 0.4kW | GDL-ACL0005-4CU | GDL-OCL0005-4CU |
| 0.75kW | GDL-ACL0006-4CU | GDL-OCL0005-4CU |
| 1.1kW | GDL-ACL0006-4CU | GDL-OCL0005-4CU |
| 1.5kW | GDL-ACL0014-4CU | GDL-OCL0006-4CU |
| 2.2kW | GDL-ACL0014-4CU | GDL-OCL0010-4CU |
| 3kW | GDL-ACL0014-4CU | GDL-OCL0010-4CU |
| 4kW | GDL-ACL0020-4CU | GDL-OCL0014-4CU |
| 5.5kW | GDL-ACL0032-4CU | GDL-OCL0020-4CU |
| 7.5kW | GDL-ACL0032-4CU | GDL-OCL0020-4CU |
| 11kW | GDL-ACL0051-4AL | GDL-OCL0035-4AL |
| 15kW | GDL-ACL0051-4AL | GDL-OCL0040-4AL |
| 18kW | GDL-ACL0070-4AL | GDL-OCL0050-4AL |
| 22kW | GDL-ACL0070-4AL | GDL-OCL0060-4AL |

Note:

- The rated input voltage drop of input reactor is designed to $\geq 1.5\%$.
- The rated output voltage drop of output reactor is designed to 1% .
- For the selection of accessories with different material requirements than those listed above, please refer to the low-voltage VFD GDL series filter option brochure.

E.3.2 Filter

A filter is used to prevent the surrounding interference and prevent the interference from the VFD during running. Optional filters can be used to meet the conductivity and transmission requirements of CE/EN 61800-3 C2 electrical drive systems.

Table E-4 Filter model selection

| VFD power | Input filter | Output filter |
|-------------------------|---------------|---------------|
| AC 1PH 200V-240V | | |
| 0.2kW | FLT-PS2010H-B | FLT-L04006L-B |
| 0.4kW | FLT-PS2010H-B | FLT-L04006L-B |
| 0.75kW | FLT-PS2010H-B | FLT-L04006L-B |
| 1.1kW | FLT-PS2025L-B | FLT-L04016L-B |
| 1.5kW | FLT-PS2025L-B | FLT-L04016L-B |
| 2.2kW | FLT-PS2025L-B | FLT-L04016L-B |
| 4kW | FLT-PS2025L-B | FLT-L04016L-B |
| AC 3PH 200V-240V | | |
| 0.2kW | FLT-P04006L-B | FLT-L04006L-B |
| 0.4kW | FLT-P04006L-B | FLT-L04006L-B |
| 0.75kW | FLT-P04016L-B | FLT-L04006L-B |
| 1.1kW | FLT-P04016L-B | FLT-L04016L-B |
| 1.5kW | FLT-P04016L-B | FLT-L04016L-B |
| 2.2kW | FLT-P04016L-B | FLT-L04016L-B |
| 4kW | FLT-P04032L-B | FLT-L04032L-B |
| 5.5kW | FLT-P04032L-B | FLT-L04032L-B |
| 7.5kW | FLT-P04045L-B | FLT-L04045L-B |
| 11kW | FLT-P04045L-B | FLT-L04045L-B |
| 15kW | FLT-P04100L-B | FLT-L04065L-B |
| AC 3PH 380V-480V | | |
| 0.4kW | FLT-P04006L-B | FLT-L04006L-B |
| 0.75kW | FLT-P04006L-B | FLT-L04006L-B |
| 1.1kW | FLT-P04006L-B | FLT-L04006L-B |
| 1.5kW | FLT-P04016L-B | FLT-L04006L-B |
| 2.2kW | FLT-P04016L-B | FLT-L04006L-B |
| 3kW | FLT-P04016L-B | FLT-L04016L-B |
| 4kW | FLT-P04016L-B | FLT-L04016L-B |
| 5.5kW | FLT-P04032L-B | FLT-L04032L-B |
| 7.5kW | FLT-P04032L-B | FLT-L04032L-B |
| 11kW | FLT-P04045L-B | FLT-L04032L-B |

| VFD power | Input filter | Output filter |
|-----------|---------------|---------------|
| 15kW | FLT-P04065L-B | FLT-L04045L-B |
| 18kW | FLT-P04065L-B | FLT-L04045L-B |
| 22kW | FLT-P04065L-B | FLT-L04065L-B |

E.3.3 Braking component

The braking component includes braking resistors and braking units, which can be used to dissipate the regenerative energy generated by the motor, greatly improving braking and deceleration capabilities. When the VFD driving a high-inertia load decelerates or needs to decelerate abruptly, the motor runs in the power generation state and transmits the load-carrying energy to the DC circuit of the VFD, causing the bus voltage of the VFD to rise. If the bus voltage exceeds a specific value, the VFD reports an overvoltage fault. To prevent this from happening, you need to configure braking components.

Table E-5 Braking component model selection

| VFD power | Braking unit | Resistance applicable for 100% braking torque (Ω) | Braking resistor dissipation power (kW) (10% braking ratio) | Braking resistor dissipation power (kW) (50% braking ratio) | Braking resistor dissipation power (kW) (80% braking ratio) | Min. allowed braking resistance (Ω) |
|-------------------------|-----------------------|---|---|---|---|-------------------------------------|
| AC 1PH 200V-240V | | | | | | |
| 0.2kW | Built-in braking unit | 750 | 0.03 | 0.15 | 0.24 | 380 |
| 0.4kW | | 361 | 0.06 | 0.3 | 0.48 | 180 |
| 0.75kW | | 192 | 0.11 | 0.56 | 0.9 | 100 |
| 1.1kW | | 131 | 0.17 | 0.83 | 1.32 | 100 |
| 1.5kW | | 96 | 0.23 | 1.1 | 1.8 | 60 |
| 2.2kW | | 65 | 0.33 | 1.7 | 2.64 | 39 |
| 4kW | | 36 | 0.6 | 3 | 4.8 | 33 |
| AC 3PH 200V-240V | | | | | | |
| 0.2kW | Built-in braking unit | 750 | 0.03 | 0.15 | 0.24 | 380 |
| 0.4kW | | 361 | 0.06 | 0.3 | 0.48 | 180 |
| 0.75kW | | 192 | 0.11 | 0.56 | 0.9 | 100 |
| 1.1kW | | 131 | 0.17 | 0.83 | 1.32 | 100 |
| 1.5kW | | 96 | 0.23 | 1.1 | 1.8 | 60 |
| 2.2kW | | 65 | 0.33 | 1.7 | 2.64 | 39 |
| 4kW | | 36 | 0.6 | 3 | 4.8 | 33 |
| 5.5kW | | 26 | 0.8 | 4.13 | 6.6 | 25 |
| 7.5kW | | 19 | 1.13 | 5.63 | 9 | 13 |

| VFD power | Braking unit | Resistance applicable for 100% braking torque (Ω) | Braking resistor dissipation power (kW) (10% braking ratio) | Braking resistor dissipation power (kW) (50% braking ratio) | Braking resistor dissipation power (kW) (80% braking ratio) | Min. allowed braking resistance (Ω) |
|-------------------------|-----------------------|--|---|---|---|--|
| 11 kW | | 13 | 1.65 | 8.3 | 13.2 | 8.8 |
| 15kW | | 9.6 | 2.3 | 11.3 | 18 | 6.4 |
| AC 3PH 380V-480V | | | | | | |
| 0.4kW | Built-in braking unit | 750 | 0.08 | 0.4 | 0.7 | 380 |
| 0.75kW | | 653 | 0.11 | 0.56 | 0.9 | 200 |
| 1.1kW | | 440 | 0.16 | 0.8 | 1.3 | 150 |
| 1.5kW | | 326 | 0.23 | 1.13 | 1.8 | 150 |
| 2.2kW | | 222 | 0.33 | 1.65 | 2.64 | 130 |
| 3kW | | 122 | 0.6 | 3 | 4.8 | 80 |
| 4kW | | 122 | 0.6 | 3 | 4.8 | 80 |
| 5.5kW | | 89 | 0.8 | 4.1 | 6.6 | 60 |
| 7.5kW | | 65 | 1.13 | 5.6 | 9 | 51 |
| 11kW | | 44 | 1.7 | 8.3 | 13.2 | 31 |
| 15kW | | 32 | 2 | 11.2 | 18 | 23 |
| 18.5kW | | 26 | 3 | 14 | 22 | 19 |
| 22kW | | 22 | 3.3 | 17 | 26 | 17 |

 **Note:**

- Select braking resistors according to the resistance and power data provided by INVT.
- The braking resistor may increase the braking torque of the VFD. The preceding table describes the resistance and power for 100% braking torque, 10% braking ratio, 50% braking ratio and 80% braking ratio. You can select the braking system based on the actual operation conditions.

E.3.4 External keypad and mounting bracket

E.3.4.1 External keypad

| | | |
|---|---|---|
| Ordering code (with package) | SOP-28 | BOP-270 |
| Appearance |  |  |

E.3.4.2 Keypad mounting bracket

All models support external keypads that are optional.

You can mount the external keypad on a bracket. There are two types of brackets that are compatible with all keypads. Keypad mounting brackets are optional. Figure E-5 show the outline dimensions.

Figure E-5 Keypad mounting bracket dimensions (unit: mm)

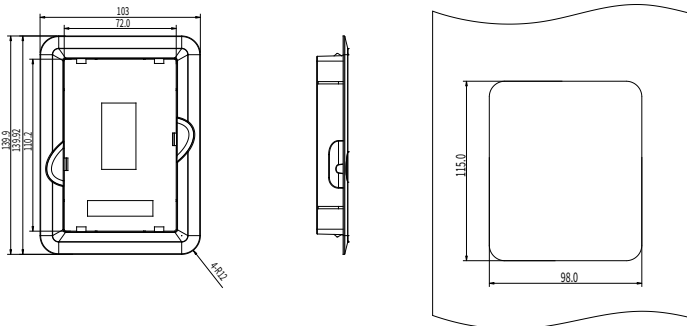

| Name | Model |
|-------------------------|------------|
| Keypad mounting bracket | GD350-JPZJ |

E.3.5 DIN rail mounting bracket

When selecting the DIN rail mounting method for the VFDs in frames A and B, you must

select rail mounting brackets.

Figure E-6 DIN rail mounting bracket dimensions (unit: mm)

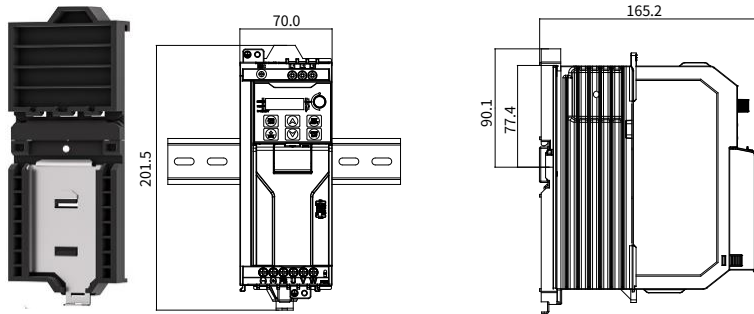

| Name | Model |
|---------------------------|------------|
| DIN rail mounting bracket | AP-RB-A-01 |

E.3.6 Accessory list

| No. | Name | Model | Applicable frame | Appearance |
|-----|---------------------------|------------|------------------|---|
| 1 | Flange mounting bracket-C | AP-FG-C-01 | C |  |
| 2 | Flange mounting bracket-D | AP-FG-D-01 | D | |
| 3 | Flange mounting bracket-E | AP-FG-E-01 | E | |

Appendix F STO function

Before starting the STO function, read the following content in detail and follow all safety precautions in this manual.

F.1 Safety standards

The product has been integrated with the STO function and complies with the following safety standards.

| | |
|------------------|---|
| IEC 61000-6-7 | Electromagnetic compatibility (EMC)—Part 7: General standards—Immunity requirements for equipment used in industrial sites to perform safety related functions (functional safety) |
| IEC 61326-3-1 | EMC requirements for measurement, control, and laboratory electrical equipment—Part 31: Immunity requirements for safety related systems and equipment intended to perform safety related functions (functional safety)—General industrial applications |
| IEC 61508 | Safety of machinery—Functional safety of safety-related control systems |
| IEC/EN 61800-5-2 | Adjustable speed electrical power drive systems Part 5-2: Safety requirements—Function |
| IEC/EN 62061 | Safety of machinery—Safety-related functional safety of electrical, electronic, and programmable electronic control systems |
| EN/ISO 13849-1 | Safety of machinery—Safety related parts of control systems—Part 1: General principles for design |
| EN/ISO 13849-2 | Safety of machinery—Safety related parts of control systems—Part 2: Verification |

Safety standard related data is as follows.

| Code | Definition | Standard | Characteristics |
|------|---------------------------------|------------------------|------------------------|
| SIL | Safety integrity level | IEC 61508 IEC 62061 | SIL3 |
| PFH | Probability of failure per hour | IEC 61508 | 8.53×10^{-10} |
| HFT | Hardware fault tolerance | IEC 61508 | 1 |
| SFF | Safe failure fraction | IEC 61508 | 99.39% |
| DC | Diagnosis coverage | ISO 13849-1 | Greater than 90% |
| Cat. | Category | ISO 13849-1 | 3 |

F.2 Safety function description

■ STO function principle description

The Safe Torque Off (STO) function turns off the drive output by shutting down the drive signal, cutting off the electrical power supply to the motor and thus stopping the outward torque output (see Figure F-2). When STO is activated, this function prevents the motor from accidentally starting if the motor is in static state. If the motor is rotating, it will continue to rotate by inertia until it comes to rest. If the motor has a brake, the brake closes immediately.

Note:

- In normal working mode, you are not recommended to use the STO function to stop the VFD running. The STO function cannot effectively prevent sabotage or misuse. If the STO function is used to stop a running VFD, the VFD will disconnect the power supply to the motor, and the motor will coast to stop. If the consequences caused by this action are unacceptable, related stop modes should be used to stop the VFD and mechanical equipment.
- When using a permanent magnet, reluctance, or nonsalient pole induction motor, even if the STO function is activated, there is still a possible failure mode (although the possibility is very low) that prevents the two power devices of the VFD from conducting. The drive system can output a uniform torque, which can rotate the permanent magnet motor shaft by a maximum electrical angle of 180°, or the non-salient pole induction motor or reluctance motor shaft by an electrical angle of 90°. This possible failure mode must be allowed during the design of the machine system. Maximum motor shaft rotation angle = Electrical angle of 360°/Number of motor pole pairs
- The STO function cannot replace the emergency stop function. When no other measures are taken, the power supply of the VFD cannot be cut off in an emergency.
- The STO function has priority over all other functions of the VFD.
- Although the STO function can reduce known hazardous conditions, it does not eliminate all potential hazards.
- Designing safety related systems requires professional safety knowledge. To ensure the safety of a complete control system, design the system according to the required safety principles. A single subsystem with the STO function, although intentionally designed for safety related applications, it cannot guarantee the safety of the entire system.

■ Emergency stop function description

When the emergency stop function is used in equipment, it mainly allows operators to take timely actions to prevent accidents in unexpected conditions. Its design may not necessarily be complex or intelligent, but it may use simple electromechanical devices to initiate a controlled rapid stop by cutting off the power supply or other means (such as dynamic or regenerative braking).

F.3 Risk assessment

1. Before using the STO function, a risk assessment needs to be conducted on the drive system to ensure compliance with the required safety standards.
2. There may also be some other risks when the device is operating with safety functions. Therefore, safety must always be considered when conducting risk assessments.
3. If an external force (such as vertical axis gravity) is applied while the safety function is in operation, the motor will rotate. Providing a separate mechanical brake is an effective solution.
4. If the drive fails, and the motor can operate within a 180° range, safety will still be ensured even in dangerous situations.

Note: The max. rotation angle of the rotating motor's shaft is 1/6 of a full turn, while the max. rotation angle of the driven motor's shaft is 1/20 of a full turn. The max. travel distance of the linear servo motor is 30mm.

F.4 STO wiring

In the factory, the STO function terminals +24V, STO1, and STO2 have been shorted.

The wiring requirements are as follows:

1. When using the STO function of the VFD, remove the jumpers between +24V, STO1, and STO1.
2. When the VFD is in normal operation, close the switches or relays.

Figure F-1 +24V/STO1/STO2 shorting connection

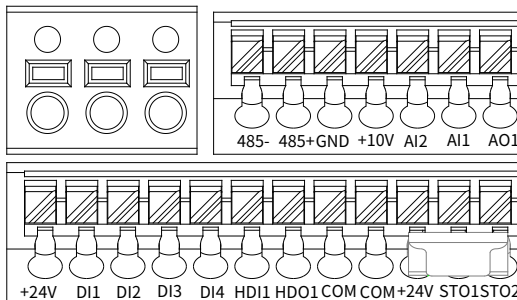

Figure F-2 STO function circuit internal power wiring

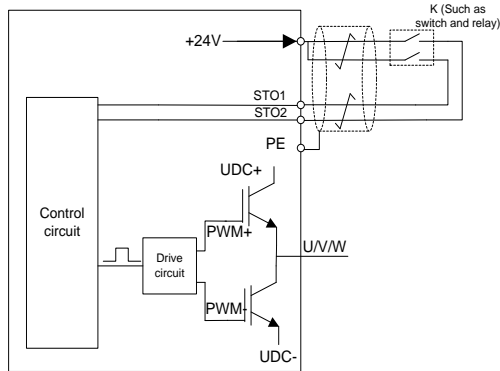
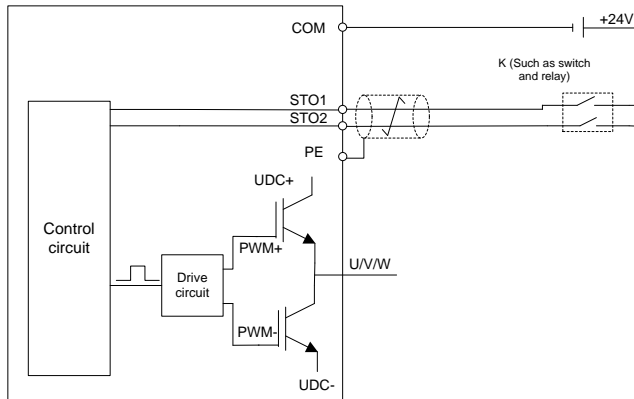

Figure F-3 STO function circuit external power wiring



Note:

- The symbol "K" in the preceding figures can represent components such as manual operation switch, emergency stop switch, safety relay, and safety PLC contact.
- The opening or closing of safety switch contact must be within 200ms.
- The maximum length of the double-shielded twisted pair cable between the VFD and safety switch is 25m.
- The cable shield layer should be connected to the PE terminal of the VFD.
- When the STO function is enabled, the switch or relay is opened. If the VFD stops output, the keypad displays "E40".

F.5 STO function terminal description

STO function terminals are listed in the following table.

| Terminal symbol | Function |
|-----------------|---|
| +24V | Voltage range: $24V \pm 15\%$ To disable the STO function, short +24V/STO1/STO2. |
| STO1 | Voltage in STO action mode: $0V < STO1$ and $STO2 < 5V$ |
| STO2 | Voltage in STO cut-off mode: $13V < STO1$ and $STO2 < 30V$ Input current: 5mA STO function channel signal input |

F.6 STO function logic table

The function logics of STO1 and STO2 and keypad display are listed in the following table.

| STO1 | STO2 | VFD status | Keypad display | Fault description |
|-------------|-------------|-------------------|------------------------|-----------------------|
| STO1 closed | STO2 closed | Normal running | No exception displayed | - |
| STO1 open | STO2 open | Torque output off | E40 | Safe torque off (STO) |
| STO1 open | STO2 closed | Torque output off | E41 | STO1 exception |
| STO1 closed | STO2 open | Torque output off | E42 | STO2 exception |

 **Note:** E43 indicates both STO1 and STO2 are abnormal.

F.7 STO channel delay description

The following table describes the trigger and indication delay of the STO channels.

Table F-1 lists the STO channel trigger and indication delay

| STO mode | STO trigger delay ¹ and STO indication delay ² |
|----------------|--|
| STO fault: E41 | Trigger delay < 10ms Indication delay < 280ms |
| STO fault: E42 | Trigger delay < 10ms Indication delay < 280ms |
| STO fault: E43 | Trigger delay < 10ms Indication delay < 280ms |
| STO fault: E40 | Trigger delay < 10ms Indication delay < 100ms |

STO trigger delay¹: Time interval between trigger the STO function and switching off the

drive output

STO instruction delay²: Time interval between triggering the STO function and indicating STO output status

F.8 Acceptance test

| Warning | |
|---|--|
|  | <ul style="list-style-type: none"> ● Technical personnel, operators, maintenance and repair personnel must receive relevant training to understand the requirements and principles of safety system design and debugging. ● Do not carry out maintenance on the VFD or motor before the power is cut off; otherwise, there may be a risk of electric shock or other electricity generated hazards. ● The safety function acceptance test must be carried out by personnel with professional safety function knowledge, and must be recorded and signed by test engineers. |

The acceptance test must be carried for the device in the following stages:

1. First starting of safety functions
2. After any safety function related change (including PCB, wiring, component, or setup)
3. After any safety function related maintenance work

The signed acceptance test report must be kept in machine logs. The report should include the documents of startup activities and test results, fault report references and fault solutions. Any new acceptance test conducted due to changes or maintenance should be recorded in the logs.

■ **Acceptance test checklist**

| Step | Test | Result |
|------|--|--------------------------|
| 1 | Ensure that the VFD can run or stop randomly during commissioning. | <input type="checkbox"/> |
| 2 | Stop the VFD (if it is running), disconnect the input power supply, and isolate the drive from the power cable through the isolation switch. | <input type="checkbox"/> |
| 3 | Check the STO function circuit connection according to the circuit diagram. | <input type="checkbox"/> |
| 4 | Close the isolation switch to connect to the power. | <input type="checkbox"/> |
| | Test the STO function as follows when the motor stops: If the VFD is running, send a stop command to it and wait until the motor shaft stops rotating. Disconnect the STO circuit. Then the VFD should enter the safe torque off mode and stop outputting voltage, and the keypad displays "E40". Send a VFD startup command, but the motor does not start. | <input type="checkbox"/> |

| Step | Test | Result |
|------|--|--------------------------|
| | <p>Close the STO circuit. Remove the fault, start the VFD, and ensure that the motor can run properly.</p> <p>Test the STO function as follows when the motor is running: Start the VFD and ensure that the motor runs. Disconnect the STO circuit. Then the VFD should enter the safe torque off mode and stop outputting voltage, and the keypad displays "E40". The motor should stop. Remove the fault, start the VFD, and ensure that the motor keeps the static state. Close the STO circuit. Remove the fault, start the VFD, and ensure that the motor can run properly.</p> | <input type="checkbox"/> |
| 5 | <p>Test and detect the VFD fault. At this time, the motor can be in running or stopped state. Start the VFD and ensure that the motor runs properly. Disconnect STO1 and keep STO2 closed. If the motor is running, it should coast to stop, and the keypad displays "E41". Send a VFD startup command, but the motor does not start. Close the STO circuit.</p> <p>At this time, the fault cannot be removed. Power off and restart the VFD, and ensure that the motor can run properly. Disconnect STO2 and keep STO1 closed. If the motor is running, it should coast to stop, and the keypad displays "E42". Send a VFD startup command, but the motor does not start. Close the STO circuit.</p> <p>At this time, the fault cannot be removed. Power off and restart the VFD, and ensure that the motor can run properly.</p> | <input type="checkbox"/> |
| 6 | <p>Record and sign the acceptance test report, which indicates the STO function is safe and can be put into service.</p> | <input type="checkbox"/> |

Note:

- If the steps in the acceptance test checklist can be carried out normally without other exceptions, it indicates that the STO functional circuit is normal. If the situations are different from the expected results of the preceding steps or if "E43" is displayed, it indicates that the STO function circuit is abnormal. For details about fault handling, see section 8.2 Faults and solutions.
- Fault "E40" can also be manually or automatically reset by setting P08.55.

| VFD fault | Fault code displayed | Response time | Reset method |
|-------------------|------------------------|---------------|------------------------------|
| Normal running | No exception displayed | - | - |
| Torque output off | E40 | ≤20ms | Press STOP/RST . |
| Torque output off | E41 | ≤20ms | Entire machine re-powered on |
| Torque output off | E42 | ≤20ms | Entire machine re-powered on |

Appendix G Function parameter list

The function parameters of the VFD are divided into groups by function. Among the function parameter groups, group P98 is the analog input and output calibration group, while group P99 contains the factory function parameters, which are user inaccessible. Each group includes several function codes (each function code identifies a function parameter). A three-level menu style is applied to function codes. For example, "P08.08" indicates the 8th function code in group P08. The VFD supplies the password protection function. For detail settings, see P07.00. The parameters adopt the decimal system (0–9) and hexadecimal system (0–F). If the hexadecimal system is adopted, all bits are mutually independent on data during parameter editing. The symbols in the table are described as follows:

"○" indicates that the value of the parameter can be modified when the VFD is in stopped or running state.

"⊙" indicates that the value of the parameter cannot be modified when the VFD is in running state.

"●" indicates that the value of the parameter is detected and recorded, and cannot be modified. (When "Restore factory settings" is performed, the actual detected parameter values or recorded values will not be restored.)

Group P00—Basic functions

| Function code | Name | Description | Default | Modify |
|---------------|-----------------------------|--|---------|--------|
| P00.00 | Speed control mode | Specifies a speed control mode. Setting range: 0–2 0: SVC mode 0 1: SVC mode 1 2: Space voltage vector control mode Note: Before using a vector control mode (0 or 1), enable the VFD to perform motor parameter autotuning first. | 2 | ⊙ |
| P00.01 | Channel of running commands | Specifies a channel of running commands. Setting range: 0–2 0: Keypad 1: Terminal 2: Communication | 0 | ○ |

| Function code | Name | Description | Default | Modify |
|---------------|--|---|---------|----------------------------------|
| P00.02 | Communication mode of running commands | The function code is used to select a communication mode of running commands. Setting range: 0–6 0: Modbus/Modbus TCP communication 1: Reserved 2: Ethernet 3: EtherCAT/PROFINET/EtherNet IP 4–6: Reserved Note: The Modbus TCP communication mode of option 0, and options 2 and 3 are extended functions, which are valid only when corresponding expansion cards are configured. | 0 | <input type="radio"/> |
| P00.03 | Max. output frequency | Specifies the max. output frequency of the VFD, which is the basis of the frequency setting and the acceleration (ACC) and deceleration (DEC) speed. Setting range: P00.04–599.00Hz | 50.00 | <input checked="" type="radio"/> |
| P00.04 | Upper limit of running frequency | Specifies the upper limit of the VFD output frequency, which should be smaller than or equal to the max. output frequency. If the set frequency is higher than the upper limit of the running frequency, the upper limit of the running frequency is used for running. Setting range: P00.05–P00.03 (Hz) | 50.00 | <input checked="" type="radio"/> |
| P00.05 | Lower limit of running frequency | Specifies the lower limit of the VFD output frequency. If the set frequency is lower than the lower limit of the running frequency, the lower limit of the running frequency is used for running. Setting range: 0.00Hz–P00.04 Note: Max. output frequency \geq Upper limit of frequency \geq Lower limit of frequency | 0.00 | <input checked="" type="radio"/> |
| P00.06 | Setting channel of A frequency command | Specifies the frequency command source. Setting range: 0–15 0: P00.10 1: All | 0 | <input type="radio"/> |

| Function code | Name | Description | Default | Modify |
|---------------|---|--|----------------|-----------------------|
| P00.07 | Setting channel of B frequency command | 2: AI2 3: AI3 4: Reserved 5: High-speed pulse HDI1 6: Reserved 7: Simple PLC program 8: Multi-step speed running 9: PID control 10: Modbus/Modbus TCP communication 11: Reserved 12: Ethernet communication 13: Reserved 14: EtherCAT/PROFINET/EtherNet IP communication 15: Reserved | 1 | <input type="radio"/> |
| P00.08 | Reference object of B frequency command | Specifies the reference object of B frequency command. Setting range: 0–1 0: Max. output frequency 1: A frequency command | 0 | <input type="radio"/> |
| P00.09 | Combination mode of setting source | Specifies the combination mode of A/B frequency setting source. Setting range: 0–5 0: A 1: B 2: (A+B) 3: (A- B) 4: Max(A, B) 5: Min. (A, B) | 0 | <input type="radio"/> |
| P00.10 | Setting frequency through keypad | Specifies the initial VFD frequency set value when A and B frequency commands are set by keypad. Setting range: 0.00Hz–P00.03 | 50.00 | <input type="radio"/> |
| P00.11 | ACC time 1 | Specifies the ACC time of ramp frequency. Setting range: 0.0–3600.0s | Model depended | <input type="radio"/> |
| P00.12 | DEC time 1 | Specifies the DEC time of ramp frequency. Setting range: 0.0–3600.0s | Model depended | <input type="radio"/> |

| Function code | Name | Description | Default | Modify |
|---------------|----------------------------|---|----------------|----------------------------------|
| P00.13 | Running direction | Specifies the running direction. Setting range: 0–2 0: Run at the default direction. 1: Run at the opposite direction. 2: Disable reverse running. | 0 | <input type="radio"/> |
| P00.14 | Carrier frequency setting | Specifies the carrier frequency. A high carrier frequency will have an ideal current waveform, few current harmonics, and small motor noise, but it will increase the switch loss, increase VFD temperature, and impact the output capacity. At the same time, the VFD current leakage and electrical magnetic interference will increase. On the contrary, an extremely-low a carrier frequency may cause unstable operation at low frequency, decrease the torque, or even lead to oscillation. The carrier frequency has been properly set in the factory before the VFD is delivered. In general, you do not need to modify it. The mapping between VFD models and default carrier frequency values is as follows: 8k for 220V 5.5kW and lower 4k for other models Setting range: 1.0kHz–15.0kHz Note: When the frequency used exceeds the default carrier frequency, the VFD needs to derate by 10% for each increased of 1kHz. | Model depended | <input type="radio"/> |
| P00.15 | Motor parameter autotuning | Specifies the motor autotuning function. Setting range: 0–3 0: No operation 1: Complete parameter rotary autotuning 2: Complete parameter static autotuning 3: Partial parameter static autotuning | 0 | <input checked="" type="radio"/> |
| P00.16 | AVR function | Specifies the VFD automatic voltage regulation (AVR) function, which can eliminate the impact of the bus voltage fluctuation on the VFD output voltage. | 1 | <input type="radio"/> |

| Function code | Name | Description | Default | Modify |
|---------------|--------------------------------|---|---------|--------|
| | | Setting range: 0–1 0: Invalid 1: Valid during the whole process | | |
| P00.17 | VFD type | Specifies the VFD type. Setting range: 0–3 0–1: Reserved 2: Heavy duty 3: Light duty Note: Invalid when the value is 0 or 1. | 2 | ⊙ |
| P00.18 | Function parameter restoration | Specifies the function parameter restoration. Setting range: 0–6 0: No operation 1: Restore to default values (excluding motor parameters) 2: Clear fault records 3: Lock all function codes 4: Reserved 5: Restore to default values (factory test mode) 6: Restore to default values (including motor parameters) Note: Restoring to default values will delete the user password. After the selected operation is performed, the function code is automatically restored to 0. When it is set to 3 (Lock all function codes), the value of any function code cannot be modified. | 0 | ⊙ |

Group P01—Start and stop control

| Function code | Name | Description | Default | Modify |
|---------------|-----------------------|--|---------|--------|
| P01.00 | Running mode of start | Specifies the start mode. Setting range: 0–4 0: Direct start 1: Start after DC braking 2–3: Reserved 4: Start after speed tracking (software) | 0 | ⊙ |

| Function code | Name | Description | Default | Modify |
|---------------|---|--|---------|--------|
| P01.01 | Starting frequency of direct start | Specifies the initial frequency during VFD start. Setting range: 0.00Hz–P00.03 | 0.50 | ⊙ |
| P01.02 | Starting frequency hold time | Specifies the hold time of starting frequency. Setting range: 0.0–50.0s | 0.0s | ⊙ |
| P01.03 | Braking current before start | Specifies the DC braking current before startup. Setting range: 0.0–100.0% | 0.0 | ⊙ |
| P01.04 | Braking time before start | Specifies the DC braking time before startup. Setting range: 0.00–50.00s | 0.00 | ⊙ |
| P01.05 | ACC/DEC mode | Specifies the changing mode of the frequency during start and running. Setting range: 0–1 0: Linear type. The output frequency increases or decreases linearly. 1: S curve. The output frequency increases or decreases according to the S curve. Note: The S curve is generally applied to application scenarios where smoother start or stop is required. When the S curve mode is selected, P01.06, P01.07, P01.27, and P01.28 need to be set accordingly. | 0 | ⊙ |
| P01.06 | Time of starting segment of ACC S curve | Specifies the time of the starting segment of the ACC S curve. It works with P01.07 to determine the curvature of the S curve. Setting range: 0.0–50.0s | 0.1 | ⊙ |
| P01.07 | Time of ending segment of ACC S curve | Specifies the time of the ending segment of the ACC S curve. It works with P01.06 to determine the curvature of the S curve. Setting range: 0.0–50.0s | 0.1 | ⊙ |
| P01.08 | Stop mode | Specifies the stop mode. Setting range: 0–1 0: Decelerate to stop. After a stop command takes effect, the VFD lowers output frequency based on the DEC mode and the defined DEC time; after the frequency drops to the stop | 0 | ○ |

| Function code | Name | Description | Default | Modify |
|---------------|--|--|---------|----------------------------------|
| | | speed (P01.15), the VFD stops. 1: Coast to stop. After a stop command takes effect, the VFD ceases the output immediately, and the load coasts to stop according to mechanical inertia. | | |
| P01.09 | Starting frequency of braking for stop | Specifies the starting frequency of DC braking for stop. Setting range: 0.00Hz~P00.03 | 0.00 | <input type="radio"/> |
| P01.10 | Demagnetization time | Specifies the demagnetization time, that is, the wait time before DC braking for stop. Setting range: 0.00~30.00s | 0.00 | <input type="radio"/> |
| P01.11 | DC braking current for stop | Specifies the DC braking current for stop, that is, the DC braking energy. Setting range: 0.0~100.0% (of the rated VFD output current) | 0.0 | <input type="radio"/> |
| P01.12 | DC braking time for stop | Specifies the duration of DC braking. Setting range: 0.00~50.00s Note: If the value is 0, DC braking is invalid, and the VFD decelerates to stop within the specified time. | 0.00 | <input type="radio"/> |
| P01.13 | FWD/REV run deadzone time | Specifies the transition time of the switching in FWD/REV running switching mode specified by P01.14. Setting range: 0.0~3600.0s | 0.0 | <input type="radio"/> |
| P01.14 | FWD/REV run switching mode | Specifies the forward/reverse running switching mode. Setting range: 0~2 0: Switch at zero frequency 1: Switch at the starting frequency 2: Switch after the speed reaches the stop speed with a delay | 1 | <input checked="" type="radio"/> |
| P01.15 | Stop speed | Specifies the stop speed (frequency). Setting range: 0.00Hz~P00.03 | 0.50 | <input checked="" type="radio"/> |
| P01.16 | Stop speed detection mode | Specifies the stop speed detection mode. The VFD stops when the value in the selected mode is less than P01.15. | 1 | <input checked="" type="radio"/> |

| Function code | Name | Description | Default | Modify |
|---------------|--|---|---------|----------------------------------|
| | | Setting range: 0–1 0: Detect according to speed setting 1: Detect according to speed feedback Note: Only "Detect according to speed setting" is valid in space voltage vector control mode. | | |
| P01.17 | Stop speed detection time | Specifies the stop speed detection time. Setting range: 0.00–100.00s | 0.00 | <input checked="" type="radio"/> |
| P01.18 | Terminal-based running command protection at power-on | Specifies whether the terminal running command is valid at power-on. Setting range: 0–1 0: The terminal running command is invalid at power-on. 1: The terminal running command is valid at power-on. | 0 | <input type="radio"/> |
| P01.19 | Action selected when running frequency less than frequency lower limit | Specifies the run status of the VFD when the set frequency is below the lower limit. Setting range: 0x00–0x12 Ones place: Action selection 0: Run at the frequency lower limit 1: Stop 2: Sleep Tens place: Stop mode 0: Coast to stop 1: Decelerate to stop Note: Valid only when frequency lower limit is greater than 0. | 0x00 | <input checked="" type="radio"/> |
| P01.20 | Wake-up-from-sleep delay | Specifies the wake-up-from-sleep delay time. Setting range: 0.0–3600.0s Note: Valid only when P01.19 ones place is 2. | 0.0 | <input type="radio"/> |
| P01.21 | Power-off restart selection | Specifies whether the VFD automatically runs after re-power on. Setting range: 0–1 0: Disable 1: Enable. If the restart condition is met, the VFD will run automatically after waiting the | 0 | <input type="radio"/> |

| Function code | Name | Description | Default | Modify |
|---------------|---|--|---------|----------------------------------|
| | | time defined by P01.22. | | |
| P01.22 | Wait time for restart after power-off | Specifies the wait time before the automatic running of the VFD that is re- powered on. Setting range: 0.0–3600.0s Note: Valid only when P01.19 ones place is 2. Valid when P01.21 is 1. | 1.0 | <input type="radio"/> |
| P01.23 | Start delay time | Setting range: 0.0–600.0s | 0.0 | <input type="radio"/> |
| P01.24 | Stop speed delay | Setting range: 0.0–600.0s | 0.0 | <input type="radio"/> |
| P01.25 | Open-loop 0Hz output selection | Setting range: 0–2 0: Output without voltage 1: Output with voltage 2: Output with the DC braking current for stop | 0 | <input type="radio"/> |
| P01.26 | DEC time for emergency stop | Setting range: 0.0–60.0s | 2.0 | <input type="radio"/> |
| P01.27 | Time of starting segment of DEC S curve | Setting range: 0.0–50.0s | 0.1 | <input checked="" type="radio"/> |
| P01.28 | Time of ending segment of DEC S curve | Setting range: 0.0–50.0s | 0.1 | <input checked="" type="radio"/> |
| P01.29–P01.31 | Reserved | - | - | - |
| P01.32 | Pre-exciting time for jogging | Setting range: 0.000–10.000s | 0.300 | <input type="radio"/> |
| P01.33 | Starting frequency of braking for stop in jogging | Setting range: 0.00Hz–P00.03 | 0.00 | <input type="radio"/> |
| P01.34 | Sleep delay | Setting range: 0–3600.0s | 0.0 | <input type="radio"/> |

| Function code | Name | Description | Default | Modify |
|---------------|---|---|---------|-----------------------|
| P01.35 | Speed tracking method | Setting range: 0x000–0x112 Ones place: Speed tracking method selection 0: Track according to stop frequency 1: Track according to rated frequency 2: Track according to max. frequency Tens place: Tracking direction 0: Single (set) direction 1: Dual (forward and reverse) directions Hundreds place: Tracking current limit (sending no wave when the value exceeded) 0: 20% (relative to the larger of VFD current and motor current) 1: 10% (relative to the larger of VFD current and motor current) | 0x000 | <input type="radio"/> |
| P01.36 | Quick/slow selection for speed tracking | Setting range: 0–10000 | 300 | <input type="radio"/> |
| P01.37 | Speed tracking voltage coefficient | Setting range: 0–50 | 10 | <input type="radio"/> |

Group P02—Parameters of motor 1

| Function code | Name | Description | Default | Modify |
|---------------|-------------------------|---|----------------|----------------------------------|
| P02.00 | Type of motor 1 | Setting range: 0–1 0: Asynchronous motor (AM) 1: Permanent magnet synchronous motor | 0 | <input checked="" type="radio"/> |
| P02.01 | Rated power of AM 1 | Setting range: 0.1–3000.0kW | Model depended | <input checked="" type="radio"/> |
| P02.02 | Rated frequency of AM 1 | Setting range: 0.01Hz–P00.03 | 50.00 | <input checked="" type="radio"/> |
| P02.03 | Rated speed of AM 1 | Setting range: 1–60000RPM | Model depended | <input checked="" type="radio"/> |

| Function code | Name | Description | Default | Modify |
|---------------|--|------------------------------|----------------|----------------------------------|
| P02.04 | Rated voltage of AM 1 | Setting range: 0–1200V | Model depended | <input checked="" type="radio"/> |
| P02.05 | Rated current of AM 1 | Setting range: 0.08–600.00A | Model depended | <input checked="" type="radio"/> |
| P02.06 | Stator resistance of AM 1 | Setting range: 0.001–65.535Ω | Model depended | <input type="radio"/> |
| P02.07 | Rotor resistance of AM 1 | Setting range: 0.001–65.535Ω | Model depended | <input type="radio"/> |
| P02.08 | Leakage inductance of AM 1 | Setting range: 0.1–6553.5mH | Model depended | <input type="radio"/> |
| P02.09 | Mutual inductance of AM 1 | Setting range: 0.1–6553.5mH | Model depended | <input type="radio"/> |
| P02.10 | No-load current of AM 1 | Setting range: 0.01–655.35A | Model depended | <input type="radio"/> |
| P02.11 | Magnetic saturation coefficient 1 of iron core of AM 1 | Setting range: 0.0–100.0% | 80.0 | <input type="radio"/> |
| P02.12 | Magnetic saturation coefficient 2 of iron core of AM 1 | Setting range: 0.0–100.0% | 68.0 | <input type="radio"/> |
| P02.13 | Magnetic saturation coefficient 3 of iron core of AM 1 | Setting range: 0.0–100.0% | 57.0 | <input type="radio"/> |

| Function code | Name | Description | Default | Modify |
|---------------|--|------------------------------|----------------|----------------------------------|
| P02.14 | Magnetic saturation coefficient 4 of iron core of AM 1 | Setting range: 0.0–100.0% | 40.0 | <input type="radio"/> |
| P02.15 | Rated power of SM 1 | Setting range: 0.1–3000.0kW | Model depended | <input checked="" type="radio"/> |
| P02.16 | Rated frequency of SM 1 | Setting range: 0.01Hz–P00.03 | 50.00 | <input checked="" type="radio"/> |
| P02.17 | Number of pole pairs of SM 1 | Setting range: 1–128 | 2 | <input checked="" type="radio"/> |
| P02.18 | Rated voltage of SM 1 | Setting range: 0–1200V | Model depended | <input checked="" type="radio"/> |
| P02.19 | Rated current of SM 1 | Setting range: 0.08–600.00A | Model depended | <input checked="" type="radio"/> |
| P02.20 | Stator resistance of SM 1 | Setting range: 0.001–65.535Ω | Model depended | <input type="radio"/> |
| P02.21 | Direct-axis inductance of SM 1 | Setting range: 0.01–655.35mH | Model depended | <input type="radio"/> |
| P02.22 | Quadrature-axis inductance of SM 1 | Setting range: 0.01–655.35mH | Model depended | <input type="radio"/> |
| P02.23 | Counter-emf constant of SM 1 | Setting range: 0–10000 | 300 | <input type="radio"/> |
| P02.24 | Initial pole position of SM 1 | Setting range: 0x0000–0xFFFF | 0x0000 | <input checked="" type="radio"/> |

| Function code | Name | Description | Default | Modify |
|---------------|---|--|---------|--------|
| P02.25 | Frequency percentage for SM 1 counter-emf identifying | Setting range: 5.0–100.0% | 60.0 | ☉ |
| P02.26 | Overload protection selection of motor 1 | Setting range: 0–2 0: No protection 1: Common motor (with low-speed compensation) As the cooling effect of a common motor is degraded at low speed running, the corresponding electronic thermal protection value needs to be adjusted properly, the low compensation indicates lowering the overload protection threshold of the motor whose running frequency is lower than 30Hz. 2: Frequency-variable motor (without low-speed compensation) The heat dissipation function for a variable-frequency motor is not impacted by the rotation speed, and therefore it is not necessary to adjust the protection value at low speed running. | 2 | ☉ |
| P02.27 | Overload protection coefficient of motor 1 | Specifies the motor overload protection coefficient. A small motor overload protection coefficient indicates a great overload multiplication (M). When M=116%, protection is performed after motor overload lasts for 1 hour; when M=150%, protection is performed after motor overload lasts for 12 minutes; when M=180%, protection is performed after motor overload lasts for 5 minutes; when M=200%, protection is performed after motor overload lasts for 60 seconds; and when M≥400%, protection is performed immediately. Setting range: 20.0%–150.0% | 100.0 | ○ |

| Function code | Name | Description | Default | Modify |
|---------------|--|---|---------|----------------------------------|
| P02.28 | Power display calibration coefficient of motor 1 | Used to adjust the power display value of motor 1. However, it does not affect the control performance of the VFD. Setting range: 0.00–3.00 | 1.00 | <input type="radio"/> |
| P02.29 | Parameter display selection of motor 1 | Setting range: 0–1 0: Display by motor type. In this mode, only parameters related to the present motor type are displayed. 1: Display all. In this mode, all the motor parameters are displayed. | 0 | <input type="radio"/> |
| P02.30 | System inertia of motor 1 | Setting range: 0.001–65.535kg · m ² | 0.001 | <input type="radio"/> |
| P02.31 | Parameter model calculation of motor 1 | Setting range: 0–1 0: Disable 1: Enable | 0 | <input checked="" type="radio"/> |
| P02.32 | Power factor of AM 1 | Setting range: 0.00–1.00 | 0.85 | <input type="radio"/> |
| P02.33 | High word of rated speed of AM 1 | Setting range: 0–30 (10kRPM) | 0 | <input checked="" type="radio"/> |
| P02.34 | Iron core saturation coefficient 1 of AM 1 | Setting range: 0.0–200.0% | 125.0 | <input type="radio"/> |
| P02.35 | Iron core saturation coefficient 2 of AM 2 | Setting range: 0.0–200.0% | 125.0 | <input type="radio"/> |
| P02.36 | Mutual inductance saturation coefficient 1 of AM 2 | Setting range: 0.0–200.0% | 88.0 | <input type="radio"/> |

| Function code | Name | Description | Default | Modify |
|---------------|--|---------------------------|---------|-----------------------|
| P02.37 | Mutual inductance saturation coefficient 2 of AM 2 | Setting range: 0.0–200.0% | 88.0 | <input type="radio"/> |
| P02.38 | Mutual inductance flux weakening coefficient 1 of AM 1 | Setting range: 0.0–200.0% | 112.5 | <input type="radio"/> |
| P02.39 | Mutual inductance flux weakening coefficient 2 of AM 1 | Setting range: 0.0–200.0% | 117.6 | <input type="radio"/> |
| P02.40 | Mutual inductance flux weakening coefficient 3 of AM 1 | Setting range: 0.0–200.0% | 122.8 | <input type="radio"/> |
| P02.41 | Mutual inductance flux weakening coefficient 4 of AM 1 | Setting range: 0.0–200.0% | 125.0 | <input type="radio"/> |

Group P03—Vector control of motor 1

| Function code | Name | Description | Default | Modify |
|---------------|---|--|---------|-----------------------|
| P03.00 | Speed-loop proportional gain 1 of motor 1 | Setting range: 0.0–200.0  Note: Applicable only to vector control mode. | 20.0 | <input type="radio"/> |

| Function code | Name | Description | Default | Modify |
|---------------|---|--|---------|-----------------------|
| P03.01 | Speed-loop integral time 1 of motor 1 | Setting range: 0.000–10.000s ⚡ Note: Applicable only to vector control mode. | 0.200 | <input type="radio"/> |
| P03.02 | Motor 1 switching low-point frequency | Setting range: 0.00Hz–P03.05 ⚡ Note: Applicable only to vector control mode. | 5.00 | <input type="radio"/> |
| P03.03 | Speed-loop proportional gain 2 of motor 1 | Setting range: 0.0–200.0 ⚡ Note: Applicable only to vector control mode. | 20.0 | <input type="radio"/> |
| P03.04 | Speed-loop integral time 2 of motor 1 | Setting range: 0.000–10.000s ⚡ Note: Applicable only to vector control mode. | 0.200 | <input type="radio"/> |
| P03.05 | Switching high-point frequency of motor 1 | Setting range: P03.02–P00.03(Hz) ⚡ Note: Applicable only to vector control mode. | 10.00 | <input type="radio"/> |
| P03.06 | Speed-loop output filter of motor 1 | Setting range: 0–8 (corresponding to 0–2 ⁸ /10ms) | 0 | <input type="radio"/> |
| P03.07 | Electromotive slip compensation coefficient of vector control for motor 1 | Slip compensation coefficient is used to adjust the slip frequency of the vector control and improve the speed control accuracy of the system. Adjusting the parameter properly can control the speed steady-state error. Setting range: 50%–200% | 100 | <input type="radio"/> |
| P03.08 | Braking slip compensation coefficient of vector control for motor 1 | Slip compensation coefficient is used to adjust the slip frequency of the vector control and improve the speed control accuracy of the system. Adjusting the parameter properly can control the speed steady-state error. Setting range: 50%–200% | 100 | <input type="radio"/> |

| Function code | Name | Description | Default | Modify |
|---------------|---|---|---------|-----------------------|
| P03.11 | Torque setting method selection of motor 1 | Setting range: 0–15 0: P03.12 1: AI1 2: AI2 3: AI3 4: Reserved 5: High-speed pulse HDI1 6–7: Reserved 8: Multi-step speed running 9: Reserved 10: Modbus/Modbus TCP communication 11: Reserved 12: Ethernet communication 13: Reserved 14: EtherCAT/PROFINET/EtherNet IP communication 15: Reserved ⚡ Note: 100% corresponds to the motor rated current. | 0 | <input type="radio"/> |
| P03.12 | Torque set through keypad of motor 1 | Setting range: -300.0%–300.0% ⚡ Note: The value is relative to the motor rated current. | 20.0 | <input type="radio"/> |
| P03.13 | Torque reference filter time of motor 1 | Setting range: 0.000–10.000s | 0.010 | <input type="radio"/> |
| P03.14 | Forward rotation upper-limit frequency source in torque control for motor 1 | Setting range: 0–15 0: Set by P03.16 1: AI1 2: AI2 3: AI3 4: Reserved 5: High-speed pulse HDI1 6–7: Reserved 8: Multi-step speed running 9: Reserved | 0 | <input type="radio"/> |

| Function code | Name | Description | Default | Modify |
|---------------|---|--|---------|--------|
| | | 10: Modbus/Modbus TCP communication 11: Reserved 12: Ethernet communication 13: Reserved 14: EtherCAT/PROFINET/EtherNet IP communication 15: Reserved ⚡ Note: For setting 1 and above, 100% corresponds to the max. frequency. | | |
| P03.15 | Reverse rotation upper-limit frequency source in torque control for motor 1 | Setting range: 0–15 0: Set by P03.17 1: AI1 2: AI2 3: AI3 4: Reserved 5: High-speed pulse HDI1 6–7: Reserved 8: Multi-step speed running 9: Reserved 10: Modbus/Modbus TCP communication 11: Reserved 12: Ethernet communication 13: Reserved 14: EtherCAT/PROFINET/EtherNet IP communication 15: Reserved ⚡ Note: For setting 1 and above, 100% corresponds to the max. frequency. | 0 | ○ |
| P03.16 | Forward rotation upper-limit frequency in torque control for motor 1 | Specifies the frequency limit when P03.14=0. Setting range: 0.00Hz–P00.03 | 50.00 | ○ |

| Function code | Name | Description | Default | Modify |
|---------------|--|--|---------|-----------------------|
| P03.17 | Reverse rotation upper-limit frequency in torque control for motor 1 | The function code is used to set the frequency limit when P03.15=0. Setting range: 0.00Hz-P00.03 | 50.00 | <input type="radio"/> |
| P03.18 | Setting source of electromotive torque upper limit for motor 1 | Setting range: 0-15 0: Set by P03.20 1: AI1 2: AI2 3: AI3 4: Reserved 5: High-speed pulse HDI1 6-9: Reserved 10: Modbus/Modbus TCP communication 11: Reserved 12: Ethernet communication 13: Reserved 14: EtherCAT/PROFINET/EtherNet IP communication 15: Reserved Note: 100% corresponds to the motor rated current. | 0 | <input type="radio"/> |
| P03.19 | Setting source of braking torque upper limit for motor 1 | Setting range: 0-15 0: Set by P03.21 1: AI1 2: AI2 3: AI3 4: Reserved 5: High-speed pulse HDI1 6-9: Reserved 10: Modbus/Modbus TCP communication 11: Reserved 12: Ethernet communication 13: Reserved 14: EtherCAT/PROFINET/EtherNet IP communication | 0 | <input type="radio"/> |

| Function code | Name | Description | Default | Modify |
|---------------|---|--|---------|-----------------------|
| | | 15: Reserved ⚡ Note: 100% corresponds to the motor rated current. | | |
| P03.20 | Electromotive torque upper limit set through keypad for motor 1 | Specifies the torque limit when P03.18 = 0. Setting range: 0.0–300.0% ⚡ Note: The value is relative to the motor rated current. | 180.0 | <input type="radio"/> |
| P03.21 | Braking torque upper limit set through keypad for motor 1 | Specifies the torque limit when P03.19 = 0. Setting range: 0.0–300.0% ⚡ Note: The value is relative to the motor rated current. | 180.0 | <input type="radio"/> |
| P03.22 | Weakening coefficient in constant power zone for motor 1 | Used when the AM is in flux-weakening control. Setting range: 0.0–200.0% | 100.0 | <input type="radio"/> |
| P03.23 | Lowest weakening point in constant power zone for motor 1 | Setting range: 5%–100% | 5 | <input type="radio"/> |
| P03.24 | Max. voltage limit on motor 1 | Specifies the max. VFD output voltage, which is a percentage of the motor rated voltage. Set the value according to onsite conditions. Setting range: 0.0–120.0% | 100.0 | <input type="radio"/> |
| P03.25 | Pre-exciting time of motor 1 | Specifies the pre-exciting time. Pre-exciting is performed for the motor when the VFD starts up. A magnetic field is built up inside the motor to improve the torque performance during the start process. Setting range: 0.000–10.000s Note: Pre-excitation can improve the start-up | 0.300 | <input type="radio"/> |

| Function code | Name | Description | Default | Modify |
|---------------|--|---|---------|-----------------------|
| | | capability of AM with loads. For an AM, set 0 to disable the pre-excitation process. For an SM, if P13.01 is set to an enabling option, the pre-excitation process is directly skipped. | | |
| P03.26 | Flux-weakening proportional gain of motor 1 | Setting range: 0–8000 | 1000 | <input type="radio"/> |
| P03.27 | Speed display selection in vector control for motor 1 | Setting range: 0–1 0: Display the actual value 1: Display the set value | 0 | <input type="radio"/> |
| P03.28 | Static friction compensation coefficient of motor 1 | Setting range: 0.0–100.0% | 0.0 | <input type="radio"/> |
| P03.29 | Static friction corresponding frequency point of motor 1 | Setting range: 0.50Hz–P03.31 | 1.00 | <input type="radio"/> |
| P03.30 | High speed friction compensation coefficient of motor 1 | Setting range: 0.0–100.0% | 0.0 | <input type="radio"/> |
| P03.31 | High speed friction corresponding frequency point of motor 1 | Setting range: P03.29–P00.03(Hz) | 50.00 | <input type="radio"/> |

| Function code | Name | Description | Default | Modify |
|---------------|--|--|---------|----------------------------------|
| P03.32 | Enabling torque control of motor 1 | Setting range: 0–1 0: Disable 1: Enable | 0 | <input type="radio"/> |
| P03.33 | Flux-weakening integral gain of motor 1 | Setting range: 0.0–300.0% | 30.0 | <input type="radio"/> |
| P03.35 | Control mode optimization selection of motor 1 | Setting range: 0x0000–0x1111 Ones place: Torque command selection 0: Torque current reference 1: Torque current reference Tens place: Reserved Hundreds place: indicates whether to enable speed-loop integral separation 0: Disable 1: Enable Thousands place: Reserved | 0x0000 | <input type="radio"/> |
| P03.36 | Speed-loop differential gain of motor 1 | Setting range: 0.00–10.00s | 0.00 | <input type="radio"/> |
| P03.43 | Motor 1 inertia identification torque | 0.0–100.0% | 10.0 | <input type="radio"/> |
| P03.44 | Enabling motor 1 inertia identification | 0–1 0: Disable 1: Enable | 0 | <input checked="" type="radio"/> |
| P03.45 | Max. flux weakening current of SM 1 | Setting range: 0.0–200.0% ⚡ Note: 100% corresponds to the motor rated current. | 100.0 | <input checked="" type="radio"/> |
| P03.46 | Vector control optimization parameter of motor 1 | Setting range: 0x0000–0x0FFF Bit 0: Enable voltage feedforward compensation (valid in FVC) Bit 1: Enable axis-d voltage cross decoupling (valid in FVC) Bit 2: Enable axis-q voltage cross decoupling | 0x0037 | <input checked="" type="radio"/> |

| Function code | Name | Description | Default | Modify |
|---------------|---|--|---------|--------|
| | | (valid in FVC) Bit 3: Enable closed-loop disturbance feedforward compensation Bit 4: Axis-q voltage restriction selection 0: Restricted to 1.2 times the motor rated voltage 1: Restricted to axis-d voltage Bit 5: Mutual inductance self-adaptation enabling 0: Invalid 1: Enable Bit 6: Direct-axis inductance (Ld) saturation enabling 0: Invalid 1: Enable (suitable for synchronous reluctance motors or synchronous motors where inductance varies significantly with current) Bit 7: Quadrature-axis inductance (Lq) saturation enabling 0: Invalid 1: Enable (suitable for synchronous reluctance motors or synchronous motors where inductance varies significantly with current) Bit 8: Torque control current optimization enabling 0: Invalid 1: Enable (suitable for low torque tension control applications) Bit 9: Current loop optimization enabling 0: Invalid 1: Enable (suitable for low carrier frequency ratio applications) Bit 10: Speed loop optimization enabling 0: Invalid 1: Enable (requiring inertia identification) Bit 11–Bit 15: Reserved | | |
| P03.49 | Closed-loop speed observation band width of motor 1 | Setting range: 1.0–200.0 | 10.0 | ○ |

| Function code | Name | Description | Default | Modify |
|---------------|---|--|---------|----------------------------------|
| P03.50 | Vector control energy-saving mode selection of motor 1 | Setting range: 0–3 0: Invalid 1: Max. efficiency (recommended) 2: Optimal power factor 3: MTPA | 0 | <input checked="" type="radio"/> |
| P03.51 | Energy-saving optimization coefficient of motor 1 | Setting range: 25.0%–400.0% | 100.0 | <input type="radio"/> |
| P03.54 | Current-loop band width of motor 1 | Setting range: 0–2000 Note: <ul style="list-style-type: none"> P03.54 is a current loop PI regulation parameter. It impacts the dynamic response speed and control accuracy of the system. Generally, you do not need to modify it. Applicable to SVC 0 (P00.00 = 0) and SVC 1 (P00.00 = 1). | 400 | <input type="radio"/> |
| P03.58 | Quick exciting current of motor 1 | 0.0–200.0% | 0.0 | <input checked="" type="radio"/> |
| P03.65 | Current-loop integral coefficient after autotuning of motor 1 | Setting range: 0–65535 | 0 | <input type="radio"/> |
| P03.68 | Upper limit frequency bias value in torque control of motor 1 | Setting range: 0.00Hz–P00.03 | 0.00 | <input type="radio"/> |

| Function code | Name | Description | Default | Modify |
|---------------|--|---|---------|-----------------------|
| P03.69 | Upper limit frequency ACC/DEC selection in torque control of motor 1 | Setting range: 0–4 0: No limit on acceleration or deceleration 1: ACC/DEC time 1 2: ACC/DEC time 2 3: ACC/DEC time 3 4: ACC/DEC time 4 | 0 | <input type="radio"/> |

Group P04—V/F control of motor 1

| Function code | Name | Description | Default | Modify |
|---------------|---------------------------------|---|---------|----------------------------------|
| P04.00 | V/F curve setting of motor 1 | Specifies the V/F curve of motor 1 to meet the needs of different loads. Setting range: 0–5 0: Straight-line V/F curve, applicable to constant torque loads 1: Multi-point V/F curve 2: Torque-down V/F curve (power of 1.3) 3: Torque-down V/F curve (power of 1.7) 4: Torque-down V/F curve (power of 2.0) Curves 2 – 4 are applicable to the torque loads such as fans and water pumps. You can adjust according to the characteristics of the loads to achieve best performance. 5: Customized V/F (V/F separation); in this mode, V can be separated from F. F can be adjusted through the frequency setting channel set by P00.06, and V can be adjusted through the voltage setting channel set by P04.13, so as to change the characteristics of the curve. | 0 | <input checked="" type="radio"/> |
| P04.01 | Torque boost of motor 1 | Setting range: 0.0–10.0% Note: 100% corresponds to the rated voltage of motor 1. When the value is set to 0.0%, the VFD uses automatic torque boost. | 0.0 | <input type="radio"/> |
| P04.02 | Torque boost cut-off of motor 1 | Setting range: 0.0–50.0% Note: 100% corresponds to the rated frequency of motor 1. | 20.0 | <input type="radio"/> |

| Function code | Name | Description | Default | Modify |
|---------------|--|--|---------|-----------------------|
| P04.03 | V/F frequency point 1 of motor 1 | When P04.00=1 (multi-dot V/F curve), you can set the V/F curve through P04.03–P04.08. Setting range: 0.00–P04.05(Hz) ⚡ Note: $V1 \leq V2 \leq V3$, $f1 \leq f2 \leq f3$ Too high voltage for low frequency will cause motor overheat or damage and cause VFD overcurrent stall or overcurrent protection. | 0.00 | <input type="radio"/> |
| P04.04 | V/F voltage point 1 of motor 1 | Setting range: 0.0–110.0% ⚡ Note: See the description for P04.03. 100% corresponds to the motor rated voltage. | 0.0 | <input type="radio"/> |
| P04.05 | V/F frequency point 2 of motor 1 | Setting range: P04.03–P04.07 (Hz) ⚡ Note: See the description for P04.03. | 0.00 | <input type="radio"/> |
| P04.06 | V/F voltage point 2 of motor 1 | Setting range: 0.0–110.0% ⚡ Note: See the description for P04.03. 100% corresponds to the motor rated voltage. | 0.0 | <input type="radio"/> |
| P04.07 | V/F frequency point 3 of motor 1 | Setting range: P04.05–P02.02 (Hz, Rated frequency of AM 1) or P04.05–P02.16 (Hz, Rated frequency of SM 1) ⚡ Note: See the description for P04.03. | 0.00 | <input type="radio"/> |
| P04.08 | V/F voltage point 3 of motor 1 | Setting range: 0.0–110.0% ⚡ Note: See the description for P04.03. 100% corresponds to the motor rated voltage. | 0.0 | <input type="radio"/> |
| P04.09 | V/F slip compensation gain of motor 1 | Used to compensate for the motor rotating speed change caused by load change in the space voltage vector mode, and thus improve the rigidity of the mechanical characteristics of the motor. Setting range: 0.0–200.0% | 100.0 | <input type="radio"/> |
| P04.10 | Low-frequency oscillation control factor of motor 1 | In space voltage vector control mode, the motor, especially the large-power motor, may experience current oscillation at certain frequencies, which may cause unstable motor running, or even VFD overcurrent. You can adjust the two function parameters properly to eliminate such phenomenon. Setting range: 0–100 | 10 | <input type="radio"/> |
| P04.11 | High-frequency oscillation control factor of motor 1 | | 10 | <input type="radio"/> |

| Function code | Name | Description | Default | Modify |
|---------------|---|--|---------|----------------------------------|
| P04.12 | Oscillation control threshold of motor 1 | Setting range: 0.00Hz–P00.03 | 30.00 | <input type="radio"/> |
| P04.13 | Voltage setting channel selection for motor 1 | Setting range: 0–15 0: Set by P04.14 1: AI1 2: AI2 3: AI3 4: Reserved 5: High-speed pulse HDI1 6–7: Reserved 8: Multi-step speed running 9: PID control 10: Modbus/Modbus TCP communication 11: Reserved 12: Ethernet communication 13: Reserved 14: EtherCAT/PROFINET/EtherNet IP communication 15: Reserved | 0 | <input type="radio"/> |
| P04.14 | Voltage set through keypad for motor 1 | The function code is the voltage digital setting when "keypad" is selected as the voltage setting channel. Setting range: 0.0–100.0% | 100.0 | <input type="radio"/> |
| P04.15 | Voltage increase time of motor 1 | Voltage increase time means the time needed for the VFD to accelerate from min. output voltage to the max. output frequency. Setting range: 0.0–3600.0s | 5.0 | <input type="radio"/> |
| P04.16 | Voltage decrease time of motor 1 | Voltage decrease time means the time needed for the VFD to decelerate from the max. output frequency to min. output voltage. Setting range: 0.0–3600.0s | 5.0 | <input type="radio"/> |
| P04.17 | Max. output voltage of motor 1 | Specifies the upper limit of output voltage. Setting range: P04.18–100.0% Note: 100% corresponds to the motor rated voltage. | 100.0 | <input checked="" type="radio"/> |

| Function code | Name | Description | Default | Modify |
|---------------|--|--|---------|--------|
| P04.18 | Min. output voltage of motor 1 | Specifies the lower limit of output voltage. Setting range: 0.0%–P04.17 ⚡ Note: 100% corresponds to the motor rated voltage. | 0.0 | ☉ |
| P04.19 | Weakening coefficient in constant power zone for motor 1 | Setting range: 1.00–1.30 | 1.00 | ○ |
| P04.20 | Pull-in current 1 in V/F control of SM 1 | When the SM V/F control mode is enabled, the function code is used to set the reactive current of the motor when the output frequency is lower than the frequency specified by P04.22. Setting range: -100.0%–100.0% ⚡ Note: 100% corresponds to the motor rated current. | 30.0 | ○ |
| P04.21 | Pull-in current 2 in V/F control of SM 1 | When the SM V/F control mode is enabled, the function code is used to set the reactive current of the motor when the output frequency is greater than the frequency specified by P04.22. Setting range: -100.0%–100.0% ⚡ Note: 100% corresponds to the motor rated current. | 10.0 | ○ |
| P04.22 | V/F control pull-in current frequency switching point for SM 1 | When the SM VF control mode is enabled, the function code is used to set the frequency threshold for the switching between pull-in current 1 and pull-in current 2. Setting range: 0.0–200.0% ⚡ Note: 100% corresponds to the motor rated frequency. | 20.0 | ○ |
| P04.23 | V/F control reactive current closed-loop proportional coefficient for SM 1 | When the SM VF control mode is enabled, the function code is used to set the proportional coefficient of reactive current closed-loop control. Setting range: 0–500 | 50 | ○ |

| Function code | Name | Description | Default | Modify |
|---------------|---|--|---------|-----------------------|
| P04.24 | V/F control reactive current closed-loop integral time for SM 1 | When the SM VF control mode is enabled, the function code is used to set the integral coefficient of reactive current closed-loop control. Setting range: 0–300 | 30 | <input type="radio"/> |
| P04.25 | V/F control reactive closed-loop output limit for SM 1 | Setting range: 0–16000 | 8000 | <input type="radio"/> |
| P04.26 | Enabling IF mode for AM 1 | Setting range: 0–1 | 0 | <input type="radio"/> |
| P04.27 | Current setting in IF mode for AM 1 | Setting range: 0.0–200.0% | 120.0 | <input type="radio"/> |
| P04.28 | Proportional coefficient in IF mode for AM 1 | Setting range: 0–5000 | 350 | <input type="radio"/> |
| P04.29 | Integral coefficient in IF mode for AM 1 | Setting range: 0–5000 | 150 | <input type="radio"/> |
| P04.30 | Frequency threshold for switching off IF mode for motor 1 | Setting range: 0.00Hz–P04.31 | 10.00 | <input type="radio"/> |
| P04.31 | End frequency point for switching off IF mode for motor 1 | Setting range: P04.30–P00.03(Hz) | 25.00 | <input type="radio"/> |

| Function code | Name | Description | Default | Modify |
|---------------|---|--|---------|-----------------------|
| P04.32 | V/F control energy-saving mode selection for AM 1 | Setting range: 0–3 0: Disable (Energy saving is invalid) 1: Max. efficiency 2: Optimal power factor 3: Max. ratio of torque to current | 0 | <input type="radio"/> |
| P04.33 | V/F control energy-saving optimization coefficient for AM 1 | Setting range: 25.0%–400.0% | 100.0 | <input type="radio"/> |

Group P05—Input terminal functions

| Function code | Name | Description | Default | Modify |
|---------------|------------------|--|---------|-----------------------|
| P05.00 | HDI input type | Setting range: 0–1 0: HDI1 is high-speed pulse input 1: HDI1 is digital input | 0 | <input type="radio"/> |
| P05.01 | Function of DI1 | Setting range: 0–95 0: No function | 1 | <input type="radio"/> |
| P05.02 | Function of DI2 | 1: Run forward 2: Run reversely | 4 | <input type="radio"/> |
| P05.03 | Function of DI3 | 3: Three-wire running control 4: Jog forward | 7 | <input type="radio"/> |
| P05.04 | Function of DI4 | 5: Jog reversely 6: Coast to stop | 0 | <input type="radio"/> |
| P05.05 | Function of DI5 | 7: Reset faults 8: Pause running | 0 | <input type="radio"/> |
| P05.06 | Function of DI6 | 9: External fault input 10: Increase frequency setting (UP) | 0 | <input type="radio"/> |
| P05.07 | Function of DI7 | 11: Decrease frequency setting (DOWN) 12: Clear the frequency increase/decrease setting | 0 | <input type="radio"/> |
| P05.08 | Function of DI8 | 13: Switch between A setting and B setting | 0 | <input type="radio"/> |
| P05.11 | Function of HDI1 | 14: Switch between combination setting and A setting | 0 | <input type="radio"/> |

| Function code | Name | Description | Default | Modify |
|---------------|------|--|---------|--------|
| | | 15: Switch between combination setting and B setting 16: Multi-step speed terminal 1 17: Multi-step speed terminal 2 18: Multi-step speed terminal 3 19: Multi-step speed terminal 4 20: Pause multi-step speed running 21: ACC/DEC time selection 1 22: ACC/DEC time selection 2 23: Simple PLC stop reset 24: Pause simple PLC 25: Pause PID control 26: Pause wobbling frequency 27: Reset wobbling frequency 28: Counter reset 29: Switch between speed control and torque control 30: Disable ACC/DEC 31: Trigger the counter 32: Motor switchover 33: Reserved 34: DC braking 35: Clear the frequency increase/decrease setting temporarily 36: Switch the running command channel to keypad 37: Switch the running command channel to terminal 38: Switch the running command channel to communication 39: Pre-exciting command 40: Clear electricity consumption 41: Keep electricity consumption 42: Switch the setting source of braking torque upper limit to keypad 43-55: Reserved 56: Emergency stop 57: Motor overtemperature fault input | | |

| Function code | Name | Description | Default | Modify |
|---------------|---------------------------|--|---------|----------------------------------|
| | | 58–60: Reserved 61: Switch PID polarities 62–95: Reserved Note: DI5–DI8 are virtual terminals enabled by P05.16 and can only be modified through communication. For Modbus/Modbus TCP communication, the virtual terminal address is 0x200A. For other communication protocols, see the PZD receiving function code options. | | |
| P05.14 | Input terminal polarity | Specifies input terminal polarity. When a bit is 0, the input terminal is positive. When a bit is 1, the input terminal is negative. Setting range: 0x000–0x7FF Bit 0: DI1 Bit 1: DI2 Bit 2: DI3 Bit 3: DI4 Bit 4: DI5 Bit 5: DI6 Bit 6: DI7 Bit 7: DI8 Bit 8: Reserved Bit 9: Reserved Bit 10: HDI1 | 0x000 | <input type="radio"/> |
| P05.15 | Digital input filter time | Specifies the sampling filter time of the DI1–DI8, and HDI1 terminals. In strong interference cases, increase the value to avoid maloperation. Setting range: 0.000–1.000s | 0.010 | <input type="radio"/> |
| P05.16 | Virtual terminal setting | Setting range: 0x000–0x7FF (0: disable; 1: enable) Bit 0: DI1 Bit 1: DI2 Bit 2: DI3 Bit 3: DI4 Bit 4: DI5 Bit 5: DI6 | 0x000 | <input checked="" type="radio"/> |

| Function code | Name | Description | Default | Modify |
|---------------|-----------------------|--|---------|----------------------------------|
| | | Bit 6: DI7 Bit 7: DI8 Bit 8: Reserved Bit 9: Reserved Bit 10: HDI1 ⚡ Note: After virtual terminals are enabled, the terminal states can only be modified through communication. For Modbus/Modbus TCP communication, the virtual terminal address is 0x200A. For other communication protocols, see the PZD receiving function code options. | | |
| P05.17 | Terminal control mode | Specifies the terminal control mode. Setting range: 0–3 0: Two-wire control mode 1 1: Two-wire control mode 2 2: Three-wire control mode 1 3: Three-wire control mode 2 | 0 | <input checked="" type="radio"/> |
| P05.18 | DI1 switch-on delay | Used to specify the delay time corresponding to the electrical level change when a programmable input terminal switches on or switches off. Setting range: 0.000–50.000s ⚡ Note: DI5–DI8 are virtual terminals enabled by P05.16 and can only be modified through communication. For Modbus/Modbus TCP communication, the virtual terminal address is 0x200A. For other communication protocols, see the PZD receiving function code options. | 0.000 | <input type="radio"/> |
| P05.19 | DI1 switch-off delay | | 0.000 | <input type="radio"/> |
| P05.20 | DI2 switch-on delay | | 0.000 | <input type="radio"/> |
| P05.21 | DI2 switch-off delay | | 0.000 | <input type="radio"/> |
| P05.22 | DI3 switch-on delay | | 0.000 | <input type="radio"/> |
| P05.23 | DI3 switch-off delay | | 0.000 | <input type="radio"/> |
| P05.24 | DI4 switch-on delay | | 0.000 | <input type="radio"/> |
| P05.25 | DI4 switch-off delay | | 0.000 | <input type="radio"/> |
| P05.26 | DI5 switch-on delay | | 0.000 | <input type="radio"/> |
| P05.27 | DI5 switch-off delay | | 0.000 | <input type="radio"/> |

| Function code | Name | Description | Default | Modify |
|---------------|--|-------------|---|--------|
| P05.28 | DI6 switch-on delay | | 0.000 | ○ |
| P05.29 | DI6 switch-off delay | | 0.000 | ○ |
| P05.30 | DI7 switch-on delay | | 0.000 | ○ |
| P05.31 | DI7 switch-off delay | | 0.000 | ○ |
| P05.32 | DI8 switch-on delay | | 0.000 | ○ |
| P05.33 | DI8 switch-off delay | | 0.000 | ○ |
| P05.38 | HDI1 switch-on delay | | 0.000 | ○ |
| P05.39 | HDI1 switch-off delay | | 0.000 | ○ |
| P05.42 | AI1 lower limit | | The function codes define the relationship between the analog input voltage and its corresponding setting. When the analog input voltage exceeds the range from the upper limit to the lower limit, the upper limit or lower limit is used. When the analog input is current input, 0mA–20mA current corresponds to 0V–10V voltage. In different applications, 100.0% of the analog setting corresponds to different nominal values. See the descriptions of each application section for details. See section 6.9.2.1 Analog input. Setting range: P05.42: 0.00V–P05.44 P05.43: -300.0%–300.0% P05.44: P05.42–10.00V P05.45: -300.0%–300.0% P05.46: 0.000–10.000s | 0.00 |
| P05.43 | Corresponding setting of AI1 lower limit | 0.0 | | ○ |
| P05.44 | AI1 upper limit | 10.00 | | ○ |
| P05.45 | Corresponding setting of AI1 upper limit | 100.0 | | ○ |
| P05.46 | AI1 input filter time | 0.030 | | ○ |
| P05.47 | AI2 lower limit | -10.00 | | ○ |
| P05.48 | Corresponding setting of AI2 lower limit | -100.0 | | ○ |
| P05.49 | AI2 middle value 1 | 0.00 | | ○ |

| Function code | Name | Description | Default | Modify |
|---------------|---|--|---------|-----------------------|
| P05.50 | Corresponding setting of AI2 middle value 1 | P05.47: -10.00V~P05.49 P05.48: -300.0%~300.0% P05.49: P05.47~P05.51(V) P05.50: -300.0%~300.0% | 0.0 | <input type="radio"/> |
| P05.51 | AI2 middle value 2 | P05.51: P05.49~P05.53(V) P05.52: -300.0%~300.0% | 0.00 | <input type="radio"/> |
| P05.52 | Corresponding setting of AI2 middle value 2 | P05.53: P05.51~10.00V P05.54: -300.0%~300.0% P05.55: 0.000~10.000s P05.56: 0.00V~P05.58 | 0.0 | <input type="radio"/> |
| P05.53 | AI2 upper limit | P05.57: -300.0%~300.0% P05.58: P05.56~10.00V P05.59: -300.0%~300.0% | 10.00 | |
| P05.54 | Corresponding setting of AI2 upper limit | P05.60: 0.000~10.000s | 100.0 | <input type="radio"/> |
| P05.55 | AI2 input filter time | Note: <ul style="list-style-type: none"> AI1: supports 0~10V, corresponding to 0~20mA. AI2: supports -10~10V, corresponding to 0~20mA. AI3: uses the keypad potentiometer as the input source. | 0.030 | <input type="radio"/> |
| P05.56 | AI3 lower limit | | 0.00 | <input type="radio"/> |
| P05.57 | Corresponding setting of AI3 lower limit | | 0.0 | <input type="radio"/> |
| P05.58 | AI3 upper limit | | 10.00 | <input type="radio"/> |
| P05.59 | Corresponding setting of AI3 upper limit | | 100.0 | <input type="radio"/> |
| P05.60 | AI3 input filter time | | 0.030 | <input type="radio"/> |
| P05.67 | Corresponding setting of HDI1 lower limit frequency | The function codes define the relationship between the high-speed pulse input and the corresponding setting. When the high-speed pulse input exceeds the range from the upper limit to the lower limit, the upper limit or lower limit is used. Setting range: P05.66: 0.000kHz~P05.68 | 0.000 | <input type="radio"/> |
| P05.68 | HDI1 upper limit frequency | | 0.0 | <input type="radio"/> |

| Function code | Name | Description | Default | Modify |
|---------------|---|---|---------|----------------------------------|
| P05.69 | Corresponding setting of HDI1 upper limit frequency | P05.67: -300.0%–300.0% P05.68: P05.66–50.000kHz P05.69: -300.0%–300.0% P05.70: 0.000–10.000s ⚡ Note: HDI1 high-speed pulse input ranges from 0.000kHz to 50.000kHz. | 50.000 | <input type="radio"/> |
| P05.70 | HDI1 frequency input filter time | | 100.0 | <input type="radio"/> |
| P05.67 | Corresponding setting of HDI1 lower limit frequency | | 0.030 | <input type="radio"/> |
| P05.76 | AI input signal type selection | Setting range: 0x0–0x3 Bit0: AI1 input signal type selection 0: Voltage 1: Current Bit1: AI2 input signal type selection 0: Voltage 1: Current ⚡ Note: The setting is made by turning the AI switch to the "I" or "V" position. | 0x0 | <input checked="" type="radio"/> |

Group P06—Output terminal functions

| Function code | Name | Description | Default | Modify |
|---------------|------------------|---|---------|----------------------------------|
| P06.00 | HDO1 output type | Setting range: 0–1 0: High-speed pulse output 1: Digital output ⚡ Note: HDO1 uses push-pull output. | 0 | <input checked="" type="radio"/> |
| P06.04 | HDO1 output | Setting range: 0–63 0: Invalid 1: Running 2: Running forward 3: Running reversely 4: Jogging | 0 | <input type="radio"/> |
| P06.05 | RO1 output | | 1 | <input type="radio"/> |

| Function code | Name | Description | Default | Modify |
|---------------|--------------------------|--|---------|--------|
| | | 5: VFD in fault 6: Frequency level detection FDT1 7: Frequency level detection FDT2 8: Frequency reached 9: Running in zero speed 10: Frequency upper limit reached 11: Frequency lower limit reached 12: Ready for running 13: Pre-exciting 14: Overload alarm 15: Underload alarm 16: Simple PLC stage completed 17: Simple PLC cycle completed 18: Set counting value reached 19: Specified counting value reached 20: External fault is valid 21: Specified function code value greater than threshold 22: Running time reached 23: Modbus/ Modbus TCP communication virtual terminal output 24: Reserved 25: Ethernet communication virtual terminal output 26: DC bus voltage established 27-28: Reserved 29: STO action 30-33: Reserved 34: EtherCAT/PROFINET/EtherNet IP communication virtual terminal output 35-36: Reserved 37: Any frequency reached 38-63: Reserved ⚡ Note: When P06.00 is set to 1, P06.04 (HDO1 output) is valid. | | |
| P06.09 | Output terminal polarity | Setting range: 0x00-0x1F Bit 0: Reserved Bit 1: Reserved Bit 2: Reserved Bit 3: HDO1 | 0x00 | ○ |

| Function code | Name | Description | Default | Modify |
|---------------|------------------------------|---|---------|--------|
| | | Bit 4: RO1 | | |
| P06.16 | HDO1 switch-on delay | Specifies the delay time corresponding to the electrical level change when a programmable output terminal switches on or switches off. Setting range: 0.000–50.000s | 0.000 | ○ |
| P06.17 | HDO1 switch-off delay | Specifies the delay time corresponding to the electrical level change when a programmable output terminal switches on or switches off. Setting range: 0.000–50.000s | 0.000 | ○ |
| P06.18 | RO1 switch-on delay | Specifies the delay time corresponding to the electrical level change when a programmable output terminal switches on or switches off. Setting range: 0.000–50.000s | 0.000- | - |
| P06.19 | RO1 switch-off delay | Specifies the delay time corresponding to the electrical level change when a programmable output terminal switches on or switches off. Setting range: 0.000–50.000s | 0.000 | ○ |
| P06.26 | AO1 output | Setting range: 0–63 | 0 | ○ |
| P06.28 | HDO1 high-speed pulse output | 0: Running frequency 1: Set frequency 2: Ramp reference frequency 3: Rotational speed (100% corresponds to the speed corresponding to the max. output frequency) 4: Output current (100% corresponds to twice the VFD rated current) 5: Output current (100% corresponds to twice the motor rated current) 6: Output voltage (100% corresponds to 1.5 times the VFD rated voltage) 7: Output power (100% corresponds to twice the motor rated power) 8: Set torque (100% corresponds to twice the motor rated torque) 9: Output torque (Absolute value, 100% corresponds to twice the motor rated torque) 10: AI1 input | 0 | ○ |

| Function code | Name | Description | Default | Modify |
|---------------|------|---|---------|--------|
| | | 11: AI2 input 12: AI3 input 13: Reserved 14: HDI1 input value 15: Reserved 16: Value 1 set through Modbus/Modbus TCP communication 17: Value 2 set through Modbus/Modbus TCP communication 18-19: Reserved 20: Value 1 set through Ethernet communication 21: Value 2 set through Ethernet communication 22: Value 1 set through EtherCAT/PROFINET/EtherNet IP communication 23: Value 2 set through EtherCAT/PROFINET/EtherNet IP communication 24: Torque current (100% corresponds to triple the motor rated current) 25: Exciting current (100% corresponds to triple the motor rated current) 26: Set frequency (bipolar) 27: Ramp reference frequency (bipolar) 28: Rotational speed of running (bipolar) 29-30: Reserved 31: Rotational speed of running (100% corresponds to the speed at twice the motor rated frequency) 32: Output torque (Actual value, 100% corresponds to twice the motor rated torque) 33: AIAO detected temperature output 34-39: Reserved 40: Specified function code value 41-63: Reserved Note: When P06.00 is set to 0, P06.28 (HDO1 | | |

| Function code | Name | Description | Default | Modify |
|---------------|--|---|---------|--------|
| | | high-speed pulse output) is valid. | | |
| P06.29 | AO1 output lower limit | The function codes define the relationship between the output value and analog output. | 0.0 | ○ |
| P06.30 | AO1 output corresponding to lower limit | When the output value exceeds the allowed range, the output uses the lower limit or upper limit. When the analog output is current output, 1mA equals 0.5V. | 0.00 | ○ |
| P06.31 | AO1 output upper limit | In different cases, the corresponding analog output of 100% of the output value is different. | 100.0 | ○ |
| P06.32 | AO1 output corresponding to upper limit | See section 6.9.2.2 Analog output. Note: AO1 supports 0–10V, corresponding to 0–20mA. | 10.00 | ○ |
| P06.33 | AO1 output filter time | Setting range: Setting range of P06.29: -300.0%–P06.31 Setting range of P06.30: 0.00–10.00V Setting range of P06.31: P06.29–300.0% Setting range of P06.32: 0.00–10.00V Setting range of P06.33: 0.000–10.000s | 0.000 | ○ |
| P06.41 | HDO1 output lower limit | The function codes define the relationship between the output value and high-speed pulse output. When the output value exceeds the allowed range, the output uses the lower limit or upper limit. | 0.0 | ○ |
| P06.42 | HDO1 output corresponding to lower limit | Setting range: Setting range of P06.41: -300.0%–P06.43 Setting range of P06.42: 0.00–50.00kHz | 0.00 | ○ |
| P06.43 | HDO1 output upper limit | Setting range of P06.43: P06.41–300.0% Setting range of P06.44: 0.00–50.00kHz Setting range of P06.45: 0.000–10.000s | 100.0 | ○ |
| P06.44 | HDO1 output corresponding to upper limit | Note: HDO1 high-speed pulse output ranges from 0.000kHz to 50.00kHz. | 50.00 | ○ |
| P06.45 | HDO1 output filter time | | 0.000 | ○ |
| P06.47 | AIAO temperature measurement selection | When AIAO temperature measurement is enabled, you need to turn the corresponding AI switch to the "V" position, set the AI input type to voltage, turn the AO switch to the "I" position, connect the temperature resistor | 0x00 | ○ |

| Function code | Name | Description | Default | Modify |
|---------------|---|---|---------|----------------------------------|
| | | between the AO terminal and GND terminal, and connect the corresponding AI terminal to the AO terminal. Setting range: 0x00–0x15 Ones place: Temperature sensor type 0: None 1: PT100 2–5: Reserved Tens place: AI input source 0: AI1 1: AI2 ⚡ Note: Before using the AI/AO temperature measurement function, ensure that AI/AO has been calibrated. | | |
| P06.48 | AIO detected temperature OT protection threshold | Setting range: 0.0–200.0°C | 110.0 | <input type="radio"/> |
| P06.51 | AIO measured temperature | Setting range: -20.0–200.0°C | 0.0 | <input checked="" type="radio"/> |
| P06.56 | Digital output specified function code | Setting range: 0.00–97.99 ⚡ Note: The setting 0 indicates invalid function code. To use this function, select 21 as the digital output function. For details, see section 6.9.1.2 Digital output. | 97.99 | <input type="radio"/> |
| P06.57 | Digital output specified function code threshold | Setting range: 0–65535 ⚡ Note: When the specified function code is a signed value, the threshold will be internally converted accordingly. | 65535 | <input type="radio"/> |
| P06.58 | Digital output specified function code hysteresis width | Setting range: 0–65535 ⚡ Note: The output is valid when the specified function code value exceeds the threshold. The output is invalid when the specified function code value plus the hysteresis width is less than or equal to the threshold. Within the hysteresis range, the output state remains unchanged. | 65535 | <input type="radio"/> |

| Function code | Name | Description | Default | Modify |
|---------------|---|--|---------|-----------------------|
| P06.59 | HDO1 high-speed pulse/AO specified function code | Setting range: 0.00–97.99 Note: The setting 0 indicates invalid function code. To use this function, select 40 as the digital output function. For details, see section 6.9.2.2 Analog output. | 97.99 | <input type="radio"/> |
| P06.60 | HDO1 high-speed pulse/AO base value | Setting range: 1–65535 | 65535 | <input type="radio"/> |
| P06.61 | HDO1 high-speed pulse/AO offset | Setting range: -100.00%–100.00% Note: When HDO1 high-speed pulse/AO1 setting is the specified function code value, the output value is calculated as: (Specified function code value/Base value) * 100.00% + Offset | 0.00 | <input type="radio"/> |

Group P07—Human-machine interface

| Function code | Name | Description | Default | Modify |
|---------------|-------------------|--|---------|----------------------------------|
| P07.00 | User password | The user password protection function is not enabled by default (that is, the default value is 0). If it is set to any non zero value, the password protection function is enabled. After you exit the function code editing interface, the password takes effect within 1 minute. When you press the PRG/JOG key, "0.0.0.0.0" is displayed. You need to enter the correct user password to enter the function code editing interface. When you set the value to 00000, the user password you have set is cleared, and the user password protection function is disabled. Setting range: 0–65535 | 0 | <input type="radio"/> |
| P07.01 | Parameter copy | Setting range: 0–4 0: No operation | 0 | <input checked="" type="radio"/> |

| Function code | Name | Description | Default | Modify |
|---------------|--|--|---------|--------|
| | | 1: Upload parameters to the keypad 2: Download all parameters (including motor parameters) 3: Download non-motor parameters 4: Download motor parameters ⚡ Note: The parameter copying function is available only with the external LCD keypad and is not supported by the local LED keypad or external LED keypad. | | |
| P07.02 | Function of QUICK/JOG | Setting range: 0x00–0x26 Ones place: Function of QUICK/JOG 0: No function 1: Jog 2: Reserved 3: Switch between forward and reverse rotating 4: Clear the UP/DOWN setting 5: Coast to stop 6: Switch command channels in sequence Tens place: Reserved ⚡ Note: The external keypad has the QUICK/JOG key, while pressing and holding the PRO/OG key on the local LED keypad performs the same function as the QUICK/JOG key. | 0x01 | ⊙ |
| P07.03 | Sequence of switching running-command channels by pressing QUICK | Specifies the sequence of switching running-command channels by pressing the key when P07.02=6. Setting range: 0–3 0: Keypad→Terminal→Communication 1: Keypad↔→Terminal 2: Keypad↔→Communication 3: Terminal↔→Communication ⚡ Note: The external keypad has the QUICK/JOG key, while pressing and holding the PRO/OG key on the local LED keypad performs the same function as the QUICK/JOG key. | 0 | ○ |

| Function code | Name | Description | Default | Modify |
|---------------|--|---|---------|-----------------------|
| P07.04 | Stop function validity of STOP/RST | Specifies the validness range of the stop function. For fault reset, the key is valid in any conditions. Setting range: 0–3 0: Valid only for keypad control 1: Valid both for keypad and terminal control 2: Valid both for keypad and communication control 3: Valid for all control modes | 0 | <input type="radio"/> |
| P07.05 | Selection 1 of parameters displayed in running state | Setting range: 0x0000–0xFFFF Bit 0: Running frequency (Hz on) Bit 1: Set frequency (Hz blinking) Bit 2: Bus voltage (V on) Bit 3: Output voltage (V on) Bit 4: Output current (A on) Bit 5: Running speed (rpm on) Bit 6: Output power (% on) Bit 7: Output torque (% on) Bit 8: PID reference value (% blinking) Bit 9: PID feedback value (% on) Bit 10: Input terminal status Bit 11: Output terminal status Bit 12: Set torque (% on) Bit 13: Pulse counting value Bit 14: Motor overload percentage (% on) Bit 15: PLC and current step number of multi-step speed | 0x03FF | <input type="radio"/> |
| P07.06 | Selection 2 of parameters displayed in running state | Setting range: 0x0000–0xFFFF Bit 0: AI1 value (V on) Bit 1: AI2 value (V on) Bit 2: AI3 value (V on) Bit 3: Reserved Bit 4: High-speed pulse HDI1 frequency Bit 5: Reserved Bit 6: VFD overload percentage (% on) Bit 7: Ramp frequency reference (Hz on) Bit 8: Linear speed Bit 9: Reserved | 0x0000 | <input type="radio"/> |

| Function code | Name | Description | Default | Modify |
|---------------|--|---|------------------|--------|
| | | Bit 10: Frequency upper limit Bit 11–Bit 15: Reserved | | |
| P07.08 | Selection 1 of parameters displayed in stopped state | Setting range: 0x0000–0xFFFF Bit 0: Set frequency (Hz on, blinking slowly) Bit 1: Bus voltage (V on) Bit 2: Input terminal status Bit 3: Output terminal status Bit 4: PID reference value (% blinking) Bit 5: PID feedback value (% on) Bit 6: Set torque (% on) Bit 7: AI1 value (V on) Bit 8: AI2 value (V on) Bit 9: AI3 value (V on) Bit 10: Reserved Bit 11: High-speed pulse HDI1 frequency Bit12: Reserved Bit 13: Count value Bit 14: PLC and actual step number of multi-step speed Bit 15: Frequency upper limit | 0x00FF | ○ |
| P07.12 | Inverter module temperature | Setting range: -20.0–120.0°C | 0.0 | ● |
| P07.13 | Control software version | Setting range: 1.00–655.35 | Version depended | ● |
| P07.14 | Drive software version | Setting range: 1.00–655.35 | Version depended | ● |
| P07.17 | VFD model | Setting range: 0x0000–0xFFFF Bit0–bit3: Reserved Bit4–bit11: Chip type and manufacturer 0x00: DSP(TI) 0x01–0xFF: Reserved Bit12–bit15: VFD series 0x0: GD28 0x1–0xF: Reserved | Model depended | ● |

| Function code | Name | Description | Default | Modify |
|---------------|---------------------|--|----------------|--------|
| P07.18 | VFD rated power | Setting range: 0.2–3000.0kW | Model depended | ● |
| P07.19 | VFD rated voltage | Setting range: 50–1200V | Model depended | ● |
| P07.20 | VFD rated current | Setting range: 0.01–600.00A | Model depended | ● |
| P07.21 | Factory bar code 1 | Setting range: 0x0000–0xFFFF | 0xFFFF | ● |
| P07.22 | Factory bar code 2 | Setting range: 0x0000–0xFFFF | 0xFFFF | ● |
| P07.23 | Factory bar code 3 | Setting range: 0x0000–0xFFFF | 0xFFFF | ● |
| P07.24 | Factory bar code 4 | Setting range: 0x0000–0xFFFF | 0xFFFF | ● |
| P07.25 | Factory bar code 5 | Setting range: 0x0000–0xFFFF | 0xFFFF | ● |
| P07.26 | Factory bar code 6 | Setting range: 0x0000–0xFFFF | 0xFFFF | ● |
| P07.27 | Present fault type | Setting range: 0–588 0: No fault | 0 | ● |
| P07.28 | Last fault type | 1–3: Reserved 4: Overcurrent during ACC (E4) | 0 | ● |
| P07.29 | 2nd-last fault type | 5: Overcurrent during DEC (E5) 6: Overcurrent during constant speed running (E6) | 0 | ● |
| P07.30 | 3rd-last fault type | 7: Overvoltage during ACC (E7) | 0 | ● |
| P07.31 | 4th-last fault type | 8: Overvoltage during DEC (E8) 9: Overvoltage during constant speed running (E9) | 0 | ● |
| P07.32 | 5th-last fault type | 10: DC bus undervoltage (E10) 11: Motor overload (E11) 12: VFD overload (E12) 13: Phase loss on input side (E13) 14: Phase loss on output side (E14) 15: Reserved 16: Inverter module overheat (E16) 17: External fault (E17) | 0 | ● |

| Function code | Name | Description | Default | Modify |
|---------------|------|--|---------|--------|
| | | 18: Modbus/Modbus TCP communication fault (E18) 19: Current detection fault (E19) 20: Motor autotuning fault (E20) 21: EEPROM operation error (E21) 22: PID feedback offline fault (E22) 23: Braking unit fault (E23) 24: Running time reached (E24) 25: Electronic overload (E25) 26: Reserved 27: Parameter upload error (E27) 28: Parameter download error (E28) 29: Reserved 30: Ethernet communication fault (E30) 31: Reserved 32: To-ground short-circuit fault (E32) 33: Reserved 34: Speed deviation fault (E34) 35: Mal-adjustment fault (E35) 36: Underload fault (E36) 37-39: Reserved 40: STO safe torque off (E40) 41: STO channel 1 safety circuit exception (E41) 42: STO channel 2 safety circuit exception (E42) 43: Exception in both STO channels 1 and 2 (E43) 44: STO safety code FLASH CRC fault (E44) 45-56: Reserved 57: PROFINET communication timeout fault (E57) 58: Reserved 59: Motor overtemperature fault (E59) 60: Communication card identifying failure (E60) 61-62: Reserved 63: Communication card communication | | |

| Function code | Name | Description | Default | Modify |
|---------------|---|--|---------|--------|
| | | timeout fault (E63) 64–65: Reserved 66: EtherCAT communication timeout fault (E66) 67–91: Reserved 92: AI1 disconnection fault (E92) 93: AI2 disconnection fault (E93) 94: AI3 disconnection fault (E94) 95: EtherNet IP communication timeout (E95) 96: No upgrade bootloader (E96) 97–586: Reserved 587: Dual-CPU communication fault 1 (E587) 588: Dual-CPU communication fault 2 (E588) | | |
| P07.33 | Running frequency at present fault | Setting range: 0.00–600.00Hz | 0.00 | ● |
| P07.34 | Ramp reference frequency at present fault | Setting range: 0.00–600.00Hz | 0.00 | ● |
| P07.35 | Output voltage at present fault | Setting range: 0–1200V | 0 | ● |
| P07.36 | Output current at present fault | Setting range: 0.00–630.00A | 0.00 | ● |
| P07.37 | Bus voltage at present fault | Setting range: 0.0–2000.0V | 0.0 | ● |
| P07.38 | Max. temperature at present fault | Setting range: -20.0–120.0°C | 0.0 | ● |
| P07.39 | Input terminal status at present fault | Setting range: 0x0000–0xFFFF | 0x0000 | ● |
| P07.40 | Output terminal state at present fault | Setting range: 0x0000–0xFFFF | 0x0000 | ● |

| Function code | Name | Description | Default | Modify |
|---------------|--|------------------------------|---------|--------|
| P07.44 | Running frequency at last fault | Setting range: 0.00–600.00Hz | 0.00 | ● |
| P07.45 | Ramp reference frequency at last fault | Setting range: 0.00–600.00Hz | 0.00 | ● |
| P07.46 | Output voltage at last fault | Setting range: 0–1200V | 0 | ● |
| P07.47 | Output current at last fault | Setting range: 0.00–630.00A | 0.00 | ● |
| P07.48 | Bus voltage at last fault | Setting range: 0.0–2000.0V | 0.0 | ● |
| P07.49 | Temperature at last fault | Setting range: -20.0–120.0°C | 0.0 | ● |
| P07.50 | Input terminal state at last fault | Setting range: 0x0000–0xFFFF | 0x0000 | ● |
| P07.51 | Output terminal state at last fault | Setting range: 0x0000–0xFFFF | 0x0000 | ● |
| P07.55 | Running frequency at 2nd-last fault | Setting range: 0.00–600.00Hz | 0.00 | ● |
| P07.56 | Ramp reference frequency at 2nd-last fault | Setting range: 0.00–600.00Hz | 0.00 | ● |
| P07.57 | Output voltage at 2nd-last fault | Setting range: 0–1200V | 0 | ● |
| P07.58 | Output current at 2nd-last fault | Setting range: 0.00–630.00A | 0.00 | ● |

| Function code | Name | Description | Default | Modify |
|---------------|--|--|---------|--------|
| P07.59 | Bus voltage at 2nd-last fault | Setting range: 0.0–2000.0V | 0.0 | ● |
| P07.60 | Temperature at 2nd-last fault | Setting range: -20.0–120.0°C | 0.0 | ● |
| P07.61 | Input terminal state at 2nd-last fault | Setting range: 0x0000–0xFFFF | 0x0000 | ● |
| P07.62 | Output terminal state at 2nd-last fault | Setting range: 0x0000–0xFFFF | 0x0000 | ● |
| P07.72 | Frequency display coefficient | Setting range: 0.01–10.00 Display frequency = Running frequency * P07.72 | 1.00 | ○ |
| P07.73 | Rotational speed display coefficient | Setting range: 0.1–999.9% Mechanical rotation speed = $120 \times (\text{Displayed running frequency}) \times P07.73 / (\text{Number of motor pole pairs})$ | 100.0 | ○ |
| P07.74 | Linear speed display coefficient | Setting range: 0.1%–999.9% Linear speed = (Mechanical rotation speed) \times P07.74 | 1.0 | ○ |
| P07.75 | Local accumulative running time Storage time | Setting range: 0–65535h | 0 | ● |
| P07.76 | VFD electricity consumption high bit | The function code is used to display the electricity consumption of the VFD. VFD electricity consumption = $P07.76 \times 1000 + P07.77$ Setting range: 0–65535kWh | 0 | ● |
| P07.77 | VFD electricity consumption low bit | The function code is used to display the electricity consumption of the VFD. VFD electricity consumption = $P07.76 \times 1000 + P07.77$ | 0.0 | ● |

| Function code | Name | Description | Default | Modify |
|---------------|------|-----------------------------|---------|--------|
| | | Setting range: 0.0–999.9kWh | | |

Group P08—Enhanced functions

| Function code | Name | Description | Default | Modify |
|---------------|-------------------------------------|---|----------------|----------------------------------|
| P08.00 | ACC time 2 | Setting range: 0.0–3600.0s | Model depended | <input type="radio"/> |
| P08.01 | DEC time 2 | Setting range: 0.0–3600.0s | Model depended | <input type="radio"/> |
| P08.02 | ACC time 3 | Setting range: 0.0–3600.0s | Model depended | <input type="radio"/> |
| P08.03 | DEC time 3 | Setting range: 0.0–3600.0s | Model depended | <input type="radio"/> |
| P08.04 | ACC time 4 | Setting range: 0.0–3600.0s | Model depended | <input type="radio"/> |
| P08.05 | DEC time 4 | Setting range: 0.0–3600.0s | Model depended | <input type="radio"/> |
| P08.06 | Switching frequency of ACC/DEC time | Setting range: 0.00Hz–P00.03 ⚡ Note: If the running frequency is greater than P08.06, switch to ACC/DEC time 2. | 0.00 | <input type="radio"/> |
| P08.07 | Reference frequency of ACC/DEC time | Setting range: 0–2 0: Max. output frequency 1: Set frequency 2: 100Hz ⚡ Note: Valid for straight ACC/DEC only. | 0 | <input checked="" type="radio"/> |
| P08.08 | Running frequency of jog | Specifies the reference frequency during jogging. Setting range: 0.00Hz–P00.03 | 5.00 | <input type="radio"/> |
| P08.09 | ACC time for jogging | Specifies the time needed for the VFD to accelerate from 0Hz to the max. output frequency (P00.03). Setting range: 0.0–3600.0s | Model depended | <input type="radio"/> |
| P08.10 | DEC time for jogging | Specifies the time needed for the VFD to decelerate from the max. output frequency (P00.03) to 0Hz. | Model depended | <input type="radio"/> |

| Function code | Name | Description | Default | Modify |
|---------------|---------------------------------------|---|---------|-----------------------|
| | | Setting range: 0.0–3600.0s | | |
| P08.11 | Jump frequency 1 | The VFD can avoid mechanical resonance points by setting jump frequencies. When the set frequency is within the range of jump frequency, the VFD runs at the boundary of jump frequency. The VFD supports the setting of three jump frequencies. If the jump frequency points are set to 0, this function is invalid. Setting range: 0.00Hz–P00.03 | 0.00 | <input type="radio"/> |
| P08.12 | Jump frequency amplitude 1 | | 0.00 | <input type="radio"/> |
| P08.13 | Jump frequency 2 | | 0.00 | <input type="radio"/> |
| P08.14 | Jump frequency amplitude 2 | | 0.00 | <input type="radio"/> |
| P08.15 | Jump frequency 3 | | 0.00 | <input type="radio"/> |
| P08.16 | Jump frequency amplitude 3 | | 0.00 | <input type="radio"/> |
| P08.17 | Amplitude of wobbling frequency | Setting range: 0.0–100.0% (of the set frequency) | 0.0 | <input type="radio"/> |
| P08.18 | Amplitude of sudden jump frequency | Setting range: 0.0–50.0% (of the amplitude of wobbling frequency) | 0.0 | <input type="radio"/> |
| P08.19 | Rise time of wobbling frequency | Setting range: 0.1–3600.0s | 5.0 | <input type="radio"/> |
| P08.20 | Fall time of wobbling frequency | Setting range: 0.1–3600.0s | 5.0 | <input type="radio"/> |
| P08.21 | Filter count in output torque display | Setting range: 0–8 | 8 | <input type="radio"/> |
| P08.22 | Output torque display selection | Setting range: 0–1 0: Based on torque current 1: Based on output power | 0 | <input type="radio"/> |

| Function code | Name | Description | Default | Modify |
|---------------|--|---|---------|----------------------------------|
| P08.23 | Number of decimal places of frequency | Setting range: 0–1 0: Two 1: One | 0 | <input type="radio"/> |
| P08.24 | Number of decimal places of linear speed | Setting range: 0–3 0: None 1: One 2: Two 3: Three | 0 | <input type="radio"/> |
| P08.25 | Set counting value | Setting range: P08.26–65535 | 0 | <input type="radio"/> |
| P08.26 | Designated counting value | Setting range: 0–P08.25 | 0 | <input type="radio"/> |
| P08.27 | Set running time | Setting range: 0–65535min | 0 | <input type="radio"/> |
| P08.28 | Auto fault reset count | Specifies the number of automatic fault reset times when the VFD uses automatic fault reset. When the number of continuous reset times exceeds the value, the VFD reports a fault and stops. After VFD starts, if no fault occurred within 600s after the VFD starts, the number of automatic fault reset times is cleared. Setting range: 0–10 | 0 | <input type="radio"/> |
| P08.29 | Auto fault reset interval | Specifies the time interval from when a fault occurred to when automatic fault reset takes effect. Setting range: 0.1–3600.0s | 1.0 | <input type="radio"/> |
| P08.31 | Motor switchover selection | 0x00–0x14 Ones place: Switchover channel 0: Terminal 1: Modbus/Modbus TCP communication 2: Reserved 3: Ethernet 4: EtherCAT/PROFINET/EtherNet IP communication | 0x00 | <input checked="" type="radio"/> |

| Function code | Name | Description | Default | Modify |
|---------------|---------------------------------------|---|---------|--------|
| | | Tens place: indicates whether to enable switchover during running 0: Disable 1: Enable | | |
| P08.32 | FDT1 electrical level detection value | Used to view the FDT1 electrical level detection value. When the output frequency exceeds the corresponding frequency of FDT electrical level, the multifunction digital output terminal continuously outputs the signal of "Frequency level detection FDT". The signal is invalid only when the output frequency decreases to a value lower than the frequency corresponding to (FDT electrical level—FDT lagging detection value). Setting range: 0.00Hz–P00.03 | 50.00 | ○ |
| P08.33 | FDT1 lagging detection value | Used to view the FDT1 lagging detection value. When the output frequency exceeds the corresponding frequency of FDT electrical level, the multifunction digital output terminal continuously outputs the signal of "Frequency level detection FDT". The signal is invalid only when the output frequency decreases to a value lower than the frequency corresponding to (FDT electrical level—FDT lagging detection value). Setting range of: 0.0–100.0% (FDT1 electrical level) | 5.0 | ○ |
| P08.34 | FDT2 electrical level detection value | Used to view the FDT2 electrical level detection value. When the output frequency exceeds the corresponding frequency of FDT electrical level, the multifunction digital output terminal continuously outputs the signal of "Frequency level detection FDT". The signal is invalid only when the output frequency decreases to a value lower than the frequency corresponding to (FDT electrical level—FDT lagging detection value). | 50.00 | ○ |

| Function code | Name | Description | Default | Modify |
|---------------|---|--|----------------|-----------------------|
| | | Setting range: 0.00Hz–P00.03 | | |
| P08.35 | FDT2 lagging detection value | Used to view the FDT2 lagging detection value. When the output frequency exceeds the corresponding frequency of FDT electrical level, the multifunction digital output terminal continuously outputs the signal of "Frequency level detection FDT". The signal is invalid only when the output frequency decreases to a value lower than the frequency corresponding to (FDT electrical level—FDT lagging detection value). Setting range: 0.0–100.0% (FDT2 electrical level) | 5.0 | <input type="radio"/> |
| P08.36 | Detection value for frequency being reached | When the output frequency is within the detection range, the multifunction digital output terminal outputs the signal of "Frequency reached". Setting range: 0.00Hz–P00.03 | 0.00 | <input type="radio"/> |
| P08.37 | Detection value for any frequency reached | Setting range: 0.00Hz–P00.03 | 1.00 | <input type="radio"/> |
| P08.38 | Detection time for any frequency reached | Setting range: 0.0–3600.0s | 0.5 | <input type="radio"/> |
| P08.39 | Enabling dynamic braking | Setting range: 0–1 0: Disable 1: Enable | 0 | <input type="radio"/> |
| P08.40 | Dynamic braking threshold voltage | Specifies the starting bus voltage of dynamic braking. Adjust this value properly to achieve effective braking for the load. The default value varies depending on the voltage class. Setting range: 200.0–2000.0V For 220V models: 380.0V For 380V models: 700.0V | Model depended | <input type="radio"/> |

| Function code | Name | Description | Default | Modify |
|---------------|--------------------------|--|---------|--------|
| P08.41 | Cooling-fan running mode | Setting range: 0x00–0x12 Ones place: Run mode 0: Normal mode 1: Permanent running after power-on 2: Run mode 2 Tens place: Speed regulation mode 0: Disable speed regulation 1: Speed regulation mode 1 ⚡ Note: In addition to the normal running requirements, run mode 2 has the feature that the fan still runs even when the ramp frequency is greater than 0. | 0x10 | ○ |
| P08.42 | PWM selection | Setting range: 0x000–0x321 Ones place: PWM mode selection 0: Switch from SVPWM to DPWM 1: SPWM overmodulation throughout the entire process Tens place: PWM low-speed carrier frequency limit 0: Low-speed carrier frequency limit mode 1 1: Low-speed carrier frequency limit mode 2 2: No limit on low-speed carrier frequency Hundreds place: Deadzone compensation method 0: Compensation method 1 1: Compensation method 2 2–3: Reserved | 0x101 | ◎ |
| P08.43 | Overmodulation selection | Setting range: 0x0000–0x1111 Ones place: Overmodulation enabling 0: Invalid 1: Enable Tens place: Overmodulation depth 0: Mild overmodulation 1: Deepened overmodulation Hundreds place: Carrier frequency limit 0: Yes 1: No limit Thousands place: Reserved | 0x1001 | ◎ |

| Function code | Name | Description | Default | Modify |
|---------------|--|---|---------|-----------------------|
| P08.44 | LED keypad control setting | Setting range: 0x0000–0x1223 Ones place: Frequency setting selection 0: Both the UP/DOWN key and digital potentiometer can be used for the control. 1: Only the UP/DOWN key can be used for the control. 2: Only the digital potentiometer can be used for the control. 3: Neither the UP/DOWN key nor the digital potentiometer can be used for the control. Tens place: Frequency control selection 0: Valid only when P00.06=0 or P00.07=0 1: Valid for all frequency setting methods 2: Invalid for multi-step speed running when multi-step speed running has the priority Hundreds place: Action selection for stop 0: Setting is valid. 1: Valid during running, cleared after stop 2: Valid during running, cleared after a stop command is received Thousands place: Indicates whether to enable the integral function through the UP/DOWN key and digital potentiometer. 0: Enable the integral function 1: Disable the integral function | 0x0000 | <input type="radio"/> |
| P08.45 | LED keypad potentiometer integral rate | Setting range: 0.01–10.00 | 0.10 | <input type="radio"/> |
| P08.46 | UP/DOWN terminal control setting | Setting range: 0x000–0x221 Ones place: Frequency setting selection 0: The setting made through UP/DOWN is valid. 1: The setting made through UP/DOWN is invalid. Tens place: Frequency control selection 0: Valid only when P00.06=0 or P00.07=0 1: Valid for all frequency setting methods 2: Invalid for multi-step speed running when | 0x000 | <input type="radio"/> |

| Function code | Name | Description | Default | Modify |
|---------------|--|---|---------|-----------------------|
| | | multi-step speed running has the priority Hundreds place: Action selection for stop 0: Setting is valid. 1: Valid during running, cleared after stop 2: Valid during running, cleared after a stop command is received | | |
| P08.47 | Frequency increment integral rate of the UP terminal | Setting range: 0.01–50.00Hz/s | 0.50 | <input type="radio"/> |
| P08.48 | Frequency integral rate of the DOWN terminal | Setting range: 0.01–50.00Hz/s | 0.50 | <input type="radio"/> |
| P08.49 | Action selection at power-off during frequency setting | Setting range: 0x000–0x111 Ones place: Reserved Action selection at power-off during frequency adjusting through Modbus communication 0: Save the setting at power-off. 1: Clear the setting at power-off. Hundreds place: Reserved | 0x000 | <input type="radio"/> |
| P08.50 | Initial electricity consumption high bit | Specifies the initial electricity consumption. Initial electricity consumption = $P08.50 \times 1000 + P08.51$ Setting range: 0–59999kkWh | 0 | <input type="radio"/> |
| P08.51 | Initial electricity consumption low bit | Specifies the initial electricity consumption. Initial electricity consumption = $P08.50 \times 1000 + P08.51$ Setting range: 0.0–999.9kWh | 0.0 | <input type="radio"/> |
| P08.52 | Magnetic flux braking | Used to enable the magnetic flux braking. Magnetic flux braking can be used for motor stop, as well as for motor rotation speed change. The current of the stator other than the rotor increases during magnetic flux braking. Therefore, the cooling is better. 0: Invalid | 0 | <input type="radio"/> |

| Function code | Name | Description | Default | Modify |
|---------------|---|---|----------------|-----------------------|
| | | 100–300: A greater coefficient indicates greater braking strength. Setting range: 0–300 | | |
| P08.53 | Magnetic flux braking ratio | Setting range: 5–15 | 8 | <input type="radio"/> |
| P08.54 | VFD input power factor | Used to adjust the current display value on the AC input side. Setting range: 0.00–1.00 | 0.56 | <input type="radio"/> |
| P08.55 | STO lock selection | Setting range: 0–1 0: Lock upon STO (E40) alarm 1: No lock on STO (E40) alarm Note: "Lock on STO (E40) alarm" indicates the STO alarm must be reset after the VFD recovers from the STO (E40) fault. "No lock on STO (E40) alarm" indicates that the STO alarm disappears automatically after the VFD recovers from the STO fault. | 0 | <input type="radio"/> |
| P08.58 | Enabling auto carrier frequency reduction | Setting range: 0–1 0: Disable 1: Enable Note: Automatic carrier frequency reduction indicates that the VFD automatically reduces the carrier frequency when detecting the heat sink temperature exceeds the rated temperature. When the temperature decreases to a specified value, the carrier frequency restores to the setting. This function can reduce the VFD overheat alarm reporting chances. | 0 | <input type="radio"/> |
| P08.59 | Min. carrier frequency | Setting range: 1.0–15.0kHz Note: It is 4k for 220V 5.5kW and lower models; it is 2k for the other models. | Model depended | <input type="radio"/> |
| P08.60 | Temperature point of auto carrier frequency reduction | Setting range: 40.0–85.0°C | 70.0 | <input type="radio"/> |

| Function code | Name | Description | Default | Modify |
|---------------|---|---|---------|----------------------------------|
| P08.61 | Interval of carrier frequency reduction | Setting range: 0–30s | 10 | <input type="radio"/> |
| P08.62 | Frequency threshold of the start of droop control | Setting range: 0.00–50.00Hz Note: The droop control function is started when P08.63 is greater than 0.00Hz. | 2.00 | <input type="radio"/> |
| P08.63 | Frequency decrease ratio in drop control | Specifies the variation rate of the VFD output frequency based on the load. It is mainly used in balancing the power when multiple motors drive the same load. Setting range: 0.00–50.00Hz | 0.00 | <input type="radio"/> |
| P08.64 | Output current filter time | Setting range: 0.000–10.000s | 0.000 | <input type="radio"/> |
| P08.66 | DPWM switching threshold frequency | Setting range: 0.0–100.0% | 25.0 | <input type="radio"/> |
| P08.67 | Random PWM depth | Setting range: 0.0–100.0% | 0.0 | <input type="radio"/> |
| P08.69 | DC bus voltage sampling delay compensation | Setting range: 0–6000 | 300 | <input type="radio"/> |
| P08.70 | Grid voltage frequency selection | 0x00–0x21 Ones place: Frequency selection 0: 50Hz 1: 60Hz Tens place: Voltage selection 0: Indicates the 220V level, suitable for the voltage range of 208–240V 1: Indicates the 380V level, suitable for the voltage range of 380–415V | 0x10 | <input checked="" type="radio"/> |

| Function code | Name | Description | Default | Modify |
|---------------|---|--|---------|-----------------------|
| | | 2: Indicates the 460V level, suitable for the voltage range of 440–480V Note: <ul style="list-style-type: none"> When the VFD model is -2/S2, the tens place of P08.70 automatically becomes 0, and the other settings (such as 1 and 2) are invalid. When the VFD model is -4, the tens place of P08.70 is 1 by default, and the other settings (such as 0) is invalid. | | |
| P08.77 | Deadzone compensation calibration coefficient | Setting range: 0.0–200.0% | 100.0 | <input type="radio"/> |

Group P09—PID control

| Function code | Name | Description | Default | Modify |
|---------------|--------------------------------|--|---------|-----------------------|
| P09.00 | PID reference source selection | Specifies the target given channel during the PID process. Setting range: 0–15 0: Setting through P09.01 1: AI1 2: AI2 3: AI3 4: Reserved 5: High-speed pulse HDI1 6–7: Reserved 8: Multi-step speed running 9: Reserved 10: Modbus/Modbus TCP communication 11: Reserved 12: Ethernet communication 13: Reserved 14: EtherCAT/PROFINET/EtherNet IP communication 15: Reserved | 0 | <input type="radio"/> |

| Function code | Name | Description | Default | Modify |
|---------------|--------------------------------------|---|---------|-----------------------|
| | | <p>⚡Note: The set target of process PID is a relative value, for which 100% equals 100% of the feedback signal of the controlled system. The system always calculates a related value (0-100.0%).</p> | | |
| P09.01 | PID digital setting | Setting range: -100.0%-100.0% | 0.0 | <input type="radio"/> |
| P09.02 | PID feedback source selection | <p>Specifies the PID feedback channel. Setting range: 0-15 0: Setting through P09.01 1: AI1 2: AI2 3: AI3 4: Reserved 5: High-speed pulse HDI1 6-9: Reserved 10: Modbus/Modbus TCP communication 11: Reserved 12: Ethernet communication 13: Reserved 14: EtherCAT/PROFINET/EtherNet IP communication 15: Reserved</p> <p>⚡Note: The reference channel and feedback channel cannot be duplicated. Otherwise, effective PID control cannot be achieved.</p> | 0 | <input type="radio"/> |
| P09.03 | PID output characteristics selection | <p>Setting range: 0-1 0: PID output is positive. When the feedback signal is greater than the PID reference value, the output frequency of the VFD will decrease to balance the PID. Example: PID control on strain during unwinding. 1: PID output is negative. When the feedback signal is greater than the PID reference value, the output frequency of the VFD will increase to balance the PID. Example: PID control on tension during unwinding</p> | 0 | <input type="radio"/> |

| Function code | Name | Description | Default | Modify |
|---------------|--|--|---------|-----------------------|
| P09.04 | Low frequency proportional gain (Kp) | Specifies the proportional gain P for the low-frequency range of PID input. Setting range: 0.00–100.00 | 1.00 | <input type="radio"/> |
| P09.05 | Low frequency integral time (Ti) | Determines the speed of the PID regulator's integration adjustment to the deviation between the PID feedback and reference in the low-frequency range. Setting range: 0.00–10.00s | 0.90 | <input type="radio"/> |
| P09.06 | Low frequency differential time (Td) | Determines the strength of the PID regulator's adjustment to the change rate of the deviation between the PID feedback and reference in the low-frequency range. Setting range: 0.00–10.00s | 0.00 | <input type="radio"/> |
| P09.07 | Low frequency point for PID parameter switching | Setting range: 0.00Hz–P09.11 | 5.00 | <input type="radio"/> |
| P09.08 | High frequency proportional gain (Kp) | Specifies the proportional gain P for the low-frequency range of PID input. Setting range: 0.00–100.00 | 1.80 | <input type="radio"/> |
| P09.09 | High frequency integral time (Ti) | Determines the speed of the PID regulator's integration adjustment to the deviation between the PID feedback and reference in the low-frequency range. Setting range: 0.00–10.00s | 0.90 | <input type="radio"/> |
| P09.10 | High frequency differential time (Td) | Determines the strength of the PID regulator's adjustment to the change rate of the deviation between the PID feedback and reference in the low-frequency range. Setting range: 0.00–10.00s | 0.00 | <input type="radio"/> |
| P09.11 | High frequency point for PID parameter switching | Setting range: P09.07–P00.03(Hz) | 10.00 | <input type="radio"/> |

| Function code | Name | Description | Default | Modify |
|---------------|----------------------------------|--|---------|-----------------------|
| P09.12 | Sampling period (T) | Specifies the sampling cycle of feedback. The regulator calculates in each sampling cycle. A longer sampling cycle indicates slower response. Setting range: 0.001–1.000s | 0.001 | <input type="radio"/> |
| P09.13 | PID control deviation limit | Specifies the max. deviation allowed by the output of PID system relative to the closed loop reference, which can adjust the accuracy and stability of the PID system. Setting range: 0.0–100.0% | 0.0 | <input type="radio"/> |
| P09.14 | PID output upper limit | The function code is used to set the upper limit of PID regulator output values. 100.0% corresponds to the max. output frequency (P00.03) or max. voltage (P04.17). Setting range: P09.15–100.0% | 100.0 | <input type="radio"/> |
| P09.15 | PID output lower limit | Specifies the lower limit of PID regulator output values. 100.0% corresponds to the max. output frequency (P00.03) or max. voltage (P04.17). Setting range: -100.0%–P09.14 | 0.0 | <input type="radio"/> |
| P09.16 | Feedback offline detection value | Specifies the PID feedback offline detection value. Setting range: 0.0–100.0% | 0.0 | <input type="radio"/> |
| P09.17 | Feedback offline detection time | Setting range: 0.0–3600.0s | 1.0 | <input type="radio"/> |
| P09.18 | PID control selection | Setting range: 0x0000–0x1111 Ones place: 0: Continue integral control after the frequency reaches upper/lower limit 1: Stop integral control after the frequency reaches upper/lower limit Tens place: 0: Same as the main reference direction 1: Contrary to the main reference direction | 0x0001 | <input type="radio"/> |

| Function code | Name | Description | Default | Modify |
|---------------|-----------------------------|---|---------|-----------------------|
| | | Hundreds place: 0: Limit as per the max. frequency 1: Limit as per A frequency Thousands place: 0: A+B frequency. ACC/DEC of main reference A frequency source pre-charging is invalid. 1: A+B frequency. ACC/DEC of main reference A frequency source buffering is valid. | | |
| P09.19 | ACC/DEC time of PID command | Setting range: 0.0–1000.0s | 0.0 | <input type="radio"/> |
| P09.20 | PID output filter time | Setting range: 0.000–10.000s | 0.000 | <input type="radio"/> |

Group P10—Simple PLC and multi-step speed control

| Function code | Name | Description | Default | Modify |
|---------------|-----------------------------|--|---------|-----------------------|
| P10.00 | Simple PLC mode | Setting range: 0–2 0: Stop after running once. The VFD stops automatically after running for one cycle, and it can be started only after receiving the running command. 1: Keep running in the final value after running for one cycle. The VFD keeps the running frequency and direction of the last section after a single cycle. 2: Cyclic running. The VFD enters the next cycle after completing one cycle until receiving the stop command. | 0 | <input type="radio"/> |
| P10.01 | Simple PLC memory selection | Setting range: 0–1 0: Do not memorize at power outage 1: Memorize at power outage. The PLC memories its running stage and running frequency before power-off. | 0 | <input type="radio"/> |
| P10.02 | Multi-step speed 0 | Setting range: -300.0%–300.0% The setting 100.0% corresponds to the max. output frequency (P00.03). | 0.0 | <input type="radio"/> |

| Function code | Name | Description | Default | Modify |
|---------------|------------------------|--|---------|-----------------------|
| P10.03 | Running time of step 0 | Setting range: 0.0–6553.5s(min) The time unit is specified by P10.37. | 0.0 | <input type="radio"/> |
| P10.04 | Multi-step speed 1 | Setting range: -300.0%–300.0% The setting 100.0% corresponds to the max. output frequency (P00.03). | 0.0 | <input type="radio"/> |
| P10.05 | Running time of step 1 | Setting range: 0.0–6553.5s(min) The time unit is specified by P10.37. | 0.0 | <input type="radio"/> |
| P10.06 | Multi-step speed 2 | Setting range: -300.0%–300.0% The setting 100.0% corresponds to the max. output frequency (P00.03). | 0.0 | <input type="radio"/> |
| P10.07 | Running time of step 2 | Setting range: 0.0–6553.5s(min) The time unit is specified by P10.37. | 0.0 | <input type="radio"/> |
| P10.08 | Multi-step speed 3 | Setting range: -300.0%–300.0% The setting 100.0% corresponds to the max. output frequency (P00.03). | 0.0 | <input type="radio"/> |
| P10.09 | Running time of step 3 | Setting range: 0.0–6553.5s(min) The time unit is specified by P10.37. | 0.0 | <input type="radio"/> |
| P10.10 | Multi-step speed 4 | Setting range: -300.0%–300.0% The setting 100.0% corresponds to the max. output frequency (P00.03). | 0.0 | <input type="radio"/> |
| P10.11 | Running time of step 4 | Setting range: 0.0–6553.5s(min) The time unit is specified by P10.37. | 0.0 | <input type="radio"/> |
| P10.12 | Multi-step speed 5 | Setting range: -300.0%–300.0% The setting 100.0% corresponds to the max. output frequency (P00.03). | 0.0 | <input type="radio"/> |
| P10.13 | Running time of step 5 | Setting range: 0.0–6553.5s(min) The time unit is specified by P10.37. | 0.0 | <input type="radio"/> |
| P10.14 | Multi-step speed 6 | Setting range: -300.0%–300.0% The setting 100.0% corresponds to the max. output frequency (P00.03). | 0.0 | <input type="radio"/> |
| P10.15 | Running time of step 6 | Setting range: 0.0–6553.5s(min) The time unit is specified by P10.37. | 0.0 | <input type="radio"/> |
| P10.16 | Multi-step speed 7 | Setting range: -300.0%–300.0% The setting 100.0% corresponds to the max. output frequency (P00.03). | 0.0 | <input type="radio"/> |
| P10.17 | Running time of step 7 | Setting range: 0.0–6553.5s(min) The time unit is specified by P10.37. | 0.0 | <input type="radio"/> |

| Function code | Name | Description | Default | Modify |
|---------------|-------------------------|--|---------|-----------------------|
| P10.18 | Multi-step speed 8 | Setting range: -300.0%~300.0% The setting 100.0% corresponds to the max. output frequency (P00.03). | 0.0 | <input type="radio"/> |
| P10.19 | Running time of step 8 | Setting range: 0.0~6553.5s(min) The time unit is specified by P10.37. | 0.0 | <input type="radio"/> |
| P10.20 | Multi-step speed 9 | Setting range: -300.0%~300.0% The setting 100.0% corresponds to the max. output frequency (P00.03). | 0.0 | <input type="radio"/> |
| P10.21 | Running time of step 9 | Setting range: 0.0~6553.5s(min) The time unit is specified by P10.37. | 0.0 | <input type="radio"/> |
| P10.22 | Multi-step speed 10 | Setting range: -300.0%~300.0% The setting 100.0% corresponds to the max. output frequency (P00.03). | 0.0 | <input type="radio"/> |
| P10.23 | Running time of step 10 | Setting range: 0.0~6553.5s(min) The time unit is specified by P10.37. | 0.0 | <input type="radio"/> |
| P10.24 | Multi-step speed 11 | Setting range: -300.0%~300.0% The setting 100.0% corresponds to the max. output frequency (P00.03). | 0.0 | <input type="radio"/> |
| P10.25 | Running time of step 11 | Setting range: 0.0~6553.5s(min) The time unit is specified by P10.37. | 0.0 | <input type="radio"/> |
| P10.26 | Multi-step speed 12 | Setting range: -300.0%~300.0% The setting 100.0% corresponds to the max. output frequency (P00.03). | 0.0 | <input type="radio"/> |
| P10.27 | Running time of step 12 | Setting range: 0.0~6553.5s(min) The time unit is specified by P10.37. | 0.0 | <input type="radio"/> |
| P10.28 | Multi-step speed 13 | Setting range: -300.0%~300.0% The setting 100.0% corresponds to the max. output frequency (P00.03). | 0.0 | <input type="radio"/> |
| P10.29 | Running time of step 13 | Setting range: 0.0~6553.5s(min) The time unit is specified by P10.37. | 0.0 | <input type="radio"/> |
| P10.30 | Multi-step speed 14 | Setting range: -300.0%~300.0% The setting 100.0% corresponds to the max. output frequency (P00.03). | 0.0 | <input type="radio"/> |
| P10.31 | Running time of step 14 | Setting range: 0.0~6553.5s(min) The time unit is specified by P10.37. | 0.0 | <input type="radio"/> |
| P10.32 | Multi-step speed 15 | Setting range: -300.0%~300.0% The setting 100.0% corresponds to the max. output frequency (P00.03). | 0.0% | <input type="radio"/> |

| Function code | Name | Description | Default | Modify |
|---------------|--|---|---------|----------------------------------|
| P10.33 | Running time of step 15 | Setting range: 0.0–6553.5s(min) The time unit is specified by P10.37. | 0.0 | <input type="radio"/> |
| P10.34 | ACC/DEC time of steps 0–7 of simple PLC | Setting range: 0x0000–0xFFFF | 0x0000 | <input type="radio"/> |
| P10.35 | ACC/DEC time of steps 8–15 of simple PLC | Setting range: 0x0000–0xFFFF | 0x0000 | <input type="radio"/> |
| P10.36 | PLC restart mode | Setting range: 0–1 0: Restart from the first step, namely if the VFD stops during running (caused by stop command, fault or power down), it will run from the first step after restart. 1: Continue running from the step frequency when interruption occurred, namely if the VFD stops during running (caused by stop command or fault), it will record the running time of current step, and enters this step automatically after restart, then continue running at the frequency defined by this step in the remaining time. | 0 | <input checked="" type="radio"/> |
| P10.37 | Multi-step running time unit | Setting range: 0–1 0: second; the running time of each step is counted in seconds 1: minute; the running time of each step is counted in minutes | 0 | <input checked="" type="radio"/> |

Group P11—Protection parameters

| Function code | Name | Description | Default | Modify |
|---------------|-------------------------------|--|---------|-----------------------|
| P11.00 | Protection against phase loss | Setting range: 0x000–0x011 Ones place: 0: Disable software input phase loss protection. 1: Enable software input phase loss | 0x011 | <input type="radio"/> |

| Function code | Name | Description | Default | Modify |
|---------------|--|--|---------|----------------------------------|
| | | protection. Tens place: 0: Disable output phase loss protection. 1: Enable output phase loss protection. Hundreds place: Reserved  Note: <ul style="list-style-type: none"> ● Even if the ones place is set to 1 for single-phase models, phase loss detection will not occur (refer to P17.68 for the model's single-phase/three-phase attributes). ● When no motor is connected, output phase loss cannot be detected, and input phase loss cannot be detected during no-load or light-load running. | | |
| P11.01 | Frequency drop at transient power-off | Setting range: 0-1 0: Disable 1: Enable | 0 | <input type="radio"/> |
| P11.02 | Enabling energy-consumption braking for stop | Setting range: 0-1 0: Disable 1: Enable | 0 | <input checked="" type="radio"/> |
| P11.03 | Overvoltage stall protection | Setting range: 0-1 0: Disable 1: Enable | 1 | <input type="radio"/> |
| P11.04 | Overvoltage stall protection voltage | 380V: 120%-150% (of standard bus voltage) | 136 | <input type="radio"/> |
| | | 220V: 120%-150% (of standard bus voltage) | 120 | |
| P11.05 | Current limit selection | During accelerated running, as the load is too large, the actual acceleration rate of motor is lower than that of output frequency. To prevent the VFD trip due to overcurrent during acceleration, take the current limit measures. Setting range: 0x00-0x11 | 0x01 | <input checked="" type="radio"/> |

| Function code | Name | Description | Default | Modify |
|---------------|--|---|---------|--------|
| | | Ones place: Current limit action selection 0: Invalid 1: Always valid Tens: Hardware current limit overload alarm selection 0: Valid 1: Invalid | | |
| P11.06 | Automatic current limit threshold | Setting range: 50.0%–200.0% (of the VFD rated output current) | 160.0 | ⊙ |
| P11.07 | Frequency decrease ratio in current limiting | Setting range: 0.00–50.00Hz/s | 10.00 | ⊙ |
| P11.08 | VFD/motor OL/UL alarm selection | Setting range: 0x0000–0x1132 Ones place: Overload/underload (OL/UL) alarm detection method 0: Motor OL/UL alarm, relative to the motor rated current. 1: VFD OL/UL alarm, relative to the VFD rated current. 2: Motor output torque OL/UL alarm, relative to motor rated torque. Tens place: Action selection upon OL/UL 0: The VFD continues to work, while keeping the OL/UL alarm. 1: For a UL fault, the VFD continues to work, while keeping the alarm; for an OL fault, it reports the fault and stops. 2: For an OL fault, the VFD continues to work, while keeping the alarm; for a UL fault, it reports the fault and stops. 3: The VFD stops running for an OL/UL alarm Hundreds place: Detection method 0: Always detect 1: Detect during constant-speed running | 0x0000 | ○ |

| Function code | Name | Description | Default | Modify |
|---------------|---|---|----------------|-----------------------|
| | | Thousands place: VFD overload current reference selection 0: Related to current calibration coefficient 1: Irrelated to current calibration coefficient | | |
| P11.09 | Underload alarm detection threshold | If the VFD or motor output current is larger than the overload pre-alarm detection level (P11.09), and the duration exceeds the overload pre-alarm detection time (P11.10), overload pre-alarm signal will be outputted. Setting range: P11.11–200% (relative value determined by the ones place of P11.08) ⚡Note: 120% by default in light load mode; 150% by default in heavy load mode. | Model depended | <input type="radio"/> |
| P11.10 | Overload alarm detection time | Setting range: 0.1–3600.0s | 1.0 | <input type="radio"/> |
| P11.11 | Underload alarm detection threshold | Underload pre-alarm signal will be outputted if the output current of the VFD or motor is lower than underload pre-alarm detection level (P11.11), and the duration exceeds underload pre-alarm detection time (P11.12). Setting range: 0%–P11.09 (relative value determined by the ones place of P11.08) | 50 | <input type="radio"/> |
| P11.12 | Underload alarm detection time | Underload pre-alarm signal will be outputted if the output current of the VFD or motor is lower than underload pre-alarm detection level (P11.11), and the duration exceeds underload pre-alarm detection time (P11.12). Setting range: 0.1–3600.0s | 1.0 | <input type="radio"/> |
| P11.13 | Fault output terminal action upon fault occurring | Specifies the action of fault output terminals at undervoltage and fault reset. Setting range: 0x00–0x11 Ones place: 0: Act at undervoltage 1: Do not act at undervoltage Tens place: | 0x00 | <input type="radio"/> |

| Function code | Name | Description | Default | Modify |
|---------------|---|---|---------|-----------------------|
| | | 0: Act during automatic reset 1: Do not act during the automatic reset period | | |
| P11.14 | Speed deviation detection value | Specifies the speed deviation detection value. Setting range: 0.0–50.0% | 10.0 | <input type="radio"/> |
| P11.15 | Speed deviation detection time | Specifies the speed deviation detection time. If the speed deviation detection time is smaller than the set value, the VFD continues running. Setting range: 0.0–10.0s Note: Speed deviation protection is invalid when P11.15 is 0.0. | 2.0 | <input type="radio"/> |
| P11.16 | Automatic frequency-reduction during voltage drop | Setting range: 0–1 0: Invalid 1: Enable | 0 | <input type="radio"/> |
| P11.17 | Proportional coefficient of voltage regulator during undervoltage stall | Specifies the proportional coefficient of the bus voltage regulator during undervoltage stall. Setting range: 0–127 | 20 | <input type="radio"/> |
| P11.18 | Integral coefficient of voltage regulator during undervoltage stall | Specifies the integral coefficient of the bus voltage regulator during undervoltage stall. Setting range: 0–1000 | 5 | <input type="radio"/> |
| P11.19 | Proportional coefficient of current regulator during undervoltage stall | Specifies the proportional coefficient of the active current regulator during undervoltage stall. Setting range: 0–1000 | 20 | <input type="radio"/> |

| Function code | Name | Description | Default | Modify |
|---------------|--|---|---------|-----------------------|
| P11.20 | Integral coefficient of current regulator during undervoltage stall | Specifies the integral coefficient of the active current regulator during undervoltage stall. Setting range: 0–2000 | 20 | <input type="radio"/> |
| P11.21 | Proportional coefficient of voltage regulator during overvoltage stall | Specifies the proportional coefficient of the bus voltage regulator during overvoltage stall. Setting range: 0–127 | 60 | <input type="radio"/> |
| P11.22 | Integral coefficient of voltage regulator during overvoltage stall | Specifies the integral coefficient of the bus voltage regulator during overvoltage stall. Setting range: 0–1000 | 5 | <input type="radio"/> |
| P11.23 | Proportional coefficient of current regulator during overvoltage stall | Specifies the proportional coefficient of the active current regulator during overvoltage stall. Setting range: 0–1000 | 60 | <input type="radio"/> |
| P11.24 | Integral coefficient of current regulator during overvoltage stall | Specifies the integral coefficient of the active current regulator during overvoltage stall. Setting range: 0–2000 | 250 | <input type="radio"/> |

| Function code | Name | Description | Default | Modify |
|---------------|--|---|---------|----------------------------------|
| P11.25 | VFD overload integral enabling | Setting range: 0–1 0: Disable. The overload timing value is reset to zero after the VFD is stopped. In this case, the determination of VFD overload takes more time, and therefore the effective protection over the VFD is weakened. 1: Enable. The overload timing value is not reset, and the overload timing value is accumulative. In this case, the determination of VFD overload takes less time, and therefore the protection over the VFD can be performed more quickly. | 0 | <input checked="" type="radio"/> |
| P11.28 | SPO switch-on detection delay time | Setting range: 0.0–60.0s Note: The SPO detection is started only after the VFD runs for the delay time P11.28 to avoid false alarms caused by the unstable frequency. | 5.0 | <input type="radio"/> |
| P11.29 | SPO imbalance factor | Setting range: 0–10 | 6 | <input type="radio"/> |
| P11.63 | Software input phase loss detection time | Setting range: 0.500–60.000s | 10.000 | <input type="radio"/> |
| P11.67 | AI1 disconnection detection threshold | Setting range: 0–100% | 0 | <input type="radio"/> |
| P11.68 | AI2 disconnection detection threshold | Setting range: 0–100% | 0 | <input type="radio"/> |
| P11.69 | AI3 disconnection detection threshold | Setting range: 0–100% | 0 | <input type="radio"/> |

Group P13—SM control

| Function code | Name | Description | Default | Modify |
|---------------|--------------------------------------|--|---------|----------------------------------|
| P13.00 | SM injected-current decrease ratio | Specifies the reduction rate of the input reactive current. When the active current of the synchronous motor increases to some extent, the input reactive current can be reduced to improve the power factor of the motor. Setting range: 0.0–100.0% (of the motor rated current) | 80.0 | <input type="radio"/> |
| P13.01 | Initial pole detection method | Setting range: 0–2 0: Do not detect 1: High-frequency superposition 2: Pulse superposition | 2 | <input checked="" type="radio"/> |
| P13.02 | Pull-in current 1 | Specifies the pole position orientation current. It is valid within the lower limit of pull-in current switch-over frequency threshold. If you need to increase the start torque, increase the value of this function parameter properly. Setting range: -100.0%–100.0% ⚡ Note: The value is relative to the motor rated current. | 30.0 | <input type="radio"/> |
| P13.03 | Pull-in current 2 | Specifies the pole position orientation current. It is valid within the upper limit of pull-in current switching frequency threshold. You do not need to change the value in most cases. Setting range: -100.0%–100.0% ⚡ Note: The value is relative to the motor rated current. | 0.0 | <input type="radio"/> |
| P13.04 | Pull-in current switching frequency | Setting range: 0.0–200.0% ⚡ Note: The value is relative to the motor rated frequency. | 20.0 | <input type="radio"/> |
| P13.06 | High-frequency superposition voltage | Specifies the pulse current threshold when the initial magnetic pole position is detected in the pulse mode. The value is a percentage in relative to the rated current of the motor. | 80.0% | <input checked="" type="radio"/> |

| Function code | Name | Description | Default | Modify |
|---------------|--|---|---------|--------|
| | | Setting range: 0.0–300.0% ⚡Note: The value is relative to the motor rated voltage. | | |
| P13.07 | Control parameter 0 | Setting range: 0.0–400.0 | 0.0 | ○ |
| P13.08 | Vector control optimization mode | Setting range: 0x0000–0xFFFF Bit 0: SM counter-emf self-adaptation Bit 1–Bit 5: Reserved Bit 6: Stator resistance self-adaptation Bit 7–Bit 15: Reserved | 0x0000 | ○ |
| P13.10 | Initial compensation angle of SM | Setting range: 0.0–359.9 | 0.0 | ○ |
| P13.11 | Mal-adjustment detection time | Used to adjust the responsiveness of anti-maladjustment function. If the load inertia is large, increase the value of this parameter properly, however, the responsiveness may slow down accordingly. Setting range: 0.0–10.0s | 0.5 | ○ |
| P13.12 | SM high-frequency compensation coefficient | Setting range: 0.0–100.0% | 0.0 | ○ |
| P13.14 | SVC speed feedback bandwidth | Setting range: 10.0–200.0rad/s | 62.5 | ◎ |
| P13.15 | SM counter-emf adaptation bandwidth | Setting range: 0.1–10.0 | 0.1 | ○ |
| P13.19 | Observer coefficient 1 | Setting range: 0–200 | 2 | ○ |
| P13.20 | Observer coefficient 2 | Setting range: 0–200 | 8 | ○ |
| P13.21 | Observer coefficient 3 | Setting range: 0.0–20.0 | 0.1 | ○ |

| Function code | Name | Description | Default | Modify |
|---------------|--|--|---------|----------------------------------|
| P13.22 | Observer coefficient 4 | Setting range: 0.0–500.0 | 0.0 | <input type="radio"/> |
| P13.26 | Vector control IF enabling | Setting range: 0x0–0x2 Ones place: Enable IF 0: Invalid 1: Valid during ACC/DEC 2: Valid only during ACC | 0x0 | <input checked="" type="radio"/> |
| P13.27 | Vector control IF current setting | Setting range: 50.0%–150.0% | 100.0 | <input type="radio"/> |
| P13.28 | Vector control IF switch-out frequency point | Setting range: 0.0–100.0% | 15.0 | <input type="radio"/> |

Group P14—Serial communication

| Function code | Name | Description | Default | Modify |
|---------------|---------------------------------|---|---------|-----------------------|
| P14.00 | Local communication address | Setting range: 1–247 If the slave communication address in the message frame sent from the master is set to 0, it serves as a broadcast communication address. All slaves on the Modbus bus will receive the frame, but the slaves will not respond to it. The communication addresses on the communication network are unique, which is the basis of the point-to-point communication. Note: The slave address cannot be set to 0. | 1 | <input type="radio"/> |
| P14.01 | Communication baud rate setting | Specifies the data transmission speed between the host controller and the VFD. Setting range: 0–7 0: 1200 bps | 4 | <input type="radio"/> |

| Function code | Name | Description | Default | Modify |
|---------------|----------------------------------|--|---------|-----------------------|
| | | 1: 2400 bps 2: 4800 bps 3: 9600 bps 4: 19200 bps 5: 38400 bps 6: 57600 bps 7: 115200 bps Note: The baud rate set on the VFD must be consistent with that on the host controller. Otherwise, the communication fails. A greater baud rate indicates faster communication. | | |
| P14.02 | Data bit check | Setting range: 0–5 0: No check (N, 8, 1) for RTU 1: Even check (E, 8, 1) for RTU 2: Odd check (O, 8, 1) for RTU 3: No check (N, 8, 2) for RTU 4: Even check (E, 8, 2) for RTU 5: Odd check (O, 8, 2) for RTU Note: The data format set on the VFD must be consistent with that on the host controller. Otherwise, the communication fails. | 1 | <input type="radio"/> |
| P14.03 | Communication response delay | Setting range: 0–200ms | 5 | <input type="radio"/> |
| P14.04 | RS485 communication timeout time | Setting range: 0.0–60.0s Note: When it is set to 0.0, the timeout is invalid. | 0.0 | <input type="radio"/> |
| P14.05 | Transmission fault processing | Setting range: 0–3 0: Report an alarm and coast to stop 1: Keep running without reporting an alarm 2: Stop in enabled stop mode without reporting an alarm (applicable only to communication mode) 3: Stop in enabled stop mode without reporting an alarm (applicable to any mode) | 0 | <input type="radio"/> |

| Function code | Name | Description | Default | Modify |
|---------------|---|--|---------|-----------------------|
| P14.06 | Modbus communication processing action selection | Setting range: 0x0000–0x1111 Ones place: 0: Respond to write operations 1: Not respond to write operations Tens place: 0: Communication password protection is invalid. 1: Communication password protection is valid. Hundreds place: 0: User-defined addresses specified in group P16 are invalid. 1: User-defined addresses specified in group P16 are valid. Thousands place: 0: CRC failure, with response of error type 0x06 1: CRC checksum failure, without response | 0x0000 | <input type="radio"/> |
| P14.48 | Channel selection for mapping between PZDs and function codes | 0x00–0x12 Ones place: Channel for mapping function codes to PZDs 0: Reserved 1: Reserved 2: Group P23 Tens place: Save function at power off 0: Disable 1: Enable | 0x12 | <input type="radio"/> |
| P14.49 | Mapped function code of received PZD2 | Setting range: 0x0000–0xFFFF | 0x0000 | <input type="radio"/> |
| P14.50 | Mapped function code of received PZD3 | Setting range: 0x0000–0xFFFF | 0x0000 | <input type="radio"/> |

| Function code | Name | Description | Default | Modify |
|---------------|--|------------------------------|---------|-----------------------|
| P14.51 | Mapped function code of received PZD4 | Setting range: 0x0000–0xFFFF | 0x0000 | <input type="radio"/> |
| P14.52 | Mapped function code of received PZD5 | Setting range: 0x0000–0xFFFF | 0x0000 | <input type="radio"/> |
| P14.53 | Mapped function code of received PZD6 | Setting range: 0x0000–0xFFFF | 0x0000 | <input type="radio"/> |
| P14.54 | Mapped function code of received PZD7 | Setting range: 0x0000–0xFFFF | 0x0000 | <input type="radio"/> |
| P14.55 | Mapped function code of received PZD8 | Setting range: 0x0000–0xFFFF | 0x0000 | <input type="radio"/> |
| P14.56 | Mapped function code of received PZD9 | Setting range: 0x0000–0xFFFF | 0x0000 | <input type="radio"/> |
| P14.57 | Mapped function code of received PZD10 | Setting range: 0x0000–0xFFFF | 0x0000 | <input type="radio"/> |
| P14.58 | Mapped function code of received PZD11 | Setting range: 0x0000–0xFFFF | 0x0000 | <input type="radio"/> |

| Function code | Name | Description | Default | Modify |
|---------------|--|------------------------------|---------|-----------------------|
| P14.59 | Mapped function code of received PZD12 | Setting range: 0x0000–0xFFFF | 0x0000 | <input type="radio"/> |
| P14.60 | Mapped function code of sent PZD2 | Setting range: 0x0000–0xFFFF | 0x0000 | <input type="radio"/> |
| P14.61 | Mapped function code of sent PZD3 | Setting range: 0x0000–0xFFFF | 0x0000 | <input type="radio"/> |
| P14.62 | Mapped function code of sent PZD4 | Setting range: 0x0000–0xFFFF | 0x0000 | <input type="radio"/> |
| P14.63 | Mapped function code of sent PZD5 | Setting range: 0x0000–0xFFFF | 0x0000 | <input type="radio"/> |
| P14.64 | Mapped function code of sent PZD6 | Setting range: 0x0000–0xFFFF | 0x0000 | <input type="radio"/> |
| P14.65 | Mapped function code of sent PZD7 | Setting range: 0x0000–0xFFFF | 0x0000 | <input type="radio"/> |
| P14.66 | Mapped function code of sent PZD8 | Setting range: 0x0000–0xFFFF | 0x0000 | <input type="radio"/> |
| P14.67 | Mapped function code of sent PZD9 | Setting range: 0x0000–0xFFFF | 0x0000 | <input type="radio"/> |

| Function code | Name | Description | Default | Modify |
|---------------|--|---|---------|----------------------------------|
| P14.68 | Mapped function code of sent PZD10 | Setting range: 0x0000–0xFFFF | 0x0000 | <input type="radio"/> |
| P14.69 | Mapped function code of sent PZD11 | Setting range: 0x0000–0xFFFF | 0x0000 | <input type="radio"/> |
| P14.70 | Mapped function code of sent PZD12 | Setting range: 0x0000–0xFFFF | 0x0000 | <input type="radio"/> |
| P14.71 | PZD communication control word expression format | Setting range: 0–1 0: Decimal format 1: Binary format | 0 | <input checked="" type="radio"/> |
| P14.76 | Enabling program upgrade | Setting range: 0–2 0: Disable 1: Upgrade main control board 2: Upgrade secondary board 1 | 0 | <input checked="" type="radio"/> |
| P14.77 | MCU bootloader software version | Setting range: 0.00–655.35 | 0.00 | <input checked="" type="radio"/> |
| P14.78 | DSP bootloader software version | Setting range: 0.00–655.35 | 0.00 | <input checked="" type="radio"/> |
| P14.79 | Display of no upgrade bootloader fault | Setting range: 0–1 0: Display 1: Do not display | 0 | <input checked="" type="radio"/> |

Group P16—Customized communication functions

| Function code | Name | Description | Default | Modify |
|---------------|--|---|---------|--------|
| P16.00 | User-defined read address 1 | Setting range: 0x0000–0xFFFF Note: When using the user-defined read/write address, you must set the hundreds place of P14.06. | 0xFFFF | ☉ |
| P16.01 | Local address corresponding to user-defined read address 1 | Setting range: 0x0000–0xFFFF | 0xFFFF | ☉ |
| P16.02 | User-defined read address 2 | Setting range: 0x0000–0xFFFF | 0xFFFF | ☉ |
| P16.03 | Local address corresponding to user-defined read address 2 | Setting range: 0x0000–0xFFFF | 0xFFFF | ☉ |
| P16.04 | User-defined read address 3 | Setting range: 0x0000–0xFFFF | 0xFFFF | ☉ |
| P16.05 | Local address corresponding to user-defined read address 3 | Setting range: 0x0000–0xFFFF | 0xFFFF | ☉ |
| P16.06 | User-defined read address 4 | Setting range: 0x0000–0xFFFF | 0xFFFF | ☉ |
| P16.07 | Local address corresponding to user-defined read address 4 | Setting range: 0x0000–0xFFFF | 0xFFFF | ☉ |
| P16.08 | User-defined read address 5 | Setting range: 0x0000–0xFFFF | 0xFFFF | ☉ |
| P16.09 | Local address corresponding to user-defined read address 5 | Setting range: 0x0000–0xFFFF | 0xFFFF | ☉ |

| Function code | Name | Description | Default | Modify |
|---------------|---|------------------------------|---------|--------|
| P16.10 | User-defined read address 6 | Setting range: 0x0000–0xFFFF | 0xFFFF | ☉ |
| P16.11 | Local address corresponding to user-defined read address 6 | Setting range: 0x0000–0xFFFF | 0xFFFF | ☉ |
| P16.12 | User-defined read address 7 | Setting range: 0x0000–0xFFFF | 0xFFFF | ☉ |
| P16.13 | Local address corresponding to user-defined read address 7 | Setting range: 0x0000–0xFFFF | 0xFFFF | ☉ |
| P16.14 | User-defined read address 8 | Setting range: 0x0000–0xFFFF | 0xFFFF | ☉ |
| P16.15 | Local address corresponding to user-defined read address 8 | Setting range: 0x0000–0xFFFF | 0xFFFF | ☉ |
| P16.16 | User-defined read address 9 | Setting range: 0x0000–0xFFFF | 0xFFFF | ☉ |
| P16.17 | Local address corresponding to user-defined read address 9 | Setting range: 0x0000–0xFFFF | 0xFFFF | ☉ |
| P16.18 | User-defined read address 10 | Setting range: 0x0000–0xFFFF | 0xFFFF | ☉ |
| P16.19 | Local address corresponding to user-defined read address 10 | Setting range: 0x0000–0xFFFF | 0xFFFF | ☉ |

| Function code | Name | Description | Default | Modify |
|---------------|---|------------------------------|---------|--------|
| P16.20 | User-defined read address 11 | Setting range: 0x0000–0xFFFF | 0xFFFF | ☉ |
| P16.21 | Local address corresponding to user-defined read address 11 | Setting range: 0x0000–0xFFFF | 0xFFFF | ☉ |
| P16.22 | User-defined read address 12 | Setting range: 0x0000–0xFFFF | 0xFFFF | ☉ |
| P16.23 | Local address corresponding to user-defined read address 12 | Setting range: 0x0000–0xFFFF | 0xFFFF | ☉ |
| P16.24 | User-defined read address 13 | Setting range: 0x0000–0xFFFF | 0xFFFF | ☉ |
| P16.25 | Local address corresponding to user-defined read address 13 | Setting range: 0x0000–0xFFFF | 0xFFFF | ☉ |
| P16.26 | User-defined read address 14 | Setting range: 0x0000–0xFFFF | 0xFFFF | ☉ |
| P16.27 | Local address corresponding to user-defined read address 14 | Setting range: 0x0000–0xFFFF | 0xFFFF | ☉ |

| Function code | Name | Description | Default | Modify |
|---------------|---|------------------------------|---------|--------|
| P16.28 | User-defined read address 15 | Setting range: 0x0000–0xFFFF | 0xFFFF | ⊙ |
| P16.29 | Local address corresponding to user-defined read address 15 | Setting range: 0x0000–0xFFFF | 0xFFFF | ⊙ |
| P16.30 | User-defined read address 16 | Setting range: 0x0000–0xFFFF | 0xFFFF | ⊙ |
| P16.31 | Local address corresponding to user-defined read address 16 | Setting range: 0x0000–0xFFFF | 0xFFFF | ⊙ |
| P16.32 | User-defined write address 1 | Setting range: 0x0000–0xFFFF | 0xFFFF | ⊙ |
| P16.33 | Local address corresponding to user-defined write address 1 | Setting range: 0x0000–0xFFFF | 0xFFFF | ⊙ |
| P16.34 | User-defined write address 2 | Setting range: 0x0000–0xFFFF | 0xFFFF | ⊙ |
| P16.35 | Local address corresponding to user-defined write address 2 | Setting range: 0x0000–0xFFFF | 0xFFFF | ⊙ |

| Function code | Name | Description | Default | Modify |
|---------------|---|------------------------------|---------|--------|
| P16.36 | User-defined write address 3 | Setting range: 0x0000–0xFFFF | 0xFFFF | ☉ |
| P16.37 | Local address corresponding to user-defined write address 3 | Setting range: 0x0000–0xFFFF | 0xFFFF | ☉ |
| P16.38 | User-defined write address 4 | Setting range: 0x0000–0xFFFF | 0xFFFF | ☉ |
| P16.39 | Local address corresponding to user-defined write address 4 | Setting range: 0x0000–0xFFFF | 0xFFFF | ☉ |
| P16.40 | User-defined write address 5 | Setting range: 0x0000–0xFFFF | 0xFFFF | ☉ |
| P16.41 | Local address corresponding to user-defined write address 5 | Setting range: 0x0000–0xFFFF | 0xFFFF | ☉ |
| P16.42 | User-defined write address 6 | Setting range: 0x0000–0xFFFF | 0xFFFF | ☉ |
| P16.43 | Local address corresponding to user-defined write address 6 | Setting range: 0x0000–0xFFFF | 0xFFFF | ☉ |

| Function code | Name | Description | Default | Modify |
|---------------|--|------------------------------|---------|--------|
| P16.44 | User-defined write address 7 | Setting range: 0x0000–0xFFFF | 0xFFFF | ☉ |
| P16.45 | Local address corresponding to user-defined write address 7 | Setting range: 0x0000–0xFFFF | 0xFFFF | ☉ |
| P16.46 | User-defined write address 8 | Setting range: 0x0000–0xFFFF | 0xFFFF | ☉ |
| P16.47 | Local address corresponding to user-defined write address 8 | Setting range: 0x0000–0xFFFF | 0xFFFF | ☉ |
| P16.48 | User-defined write address 9 | Setting range: 0x0000–0xFFFF | 0xFFFF | ☉ |
| P16.49 | Local address corresponding to user-defined write address 9 | Setting range: 0x0000–0xFFFF | 0xFFFF | ☉ |
| P16.50 | User-defined write address 10 | Setting range: 0x0000–0xFFFF | 0xFFFF | ☉ |
| P16.51 | Local address corresponding to user-defined write address 10 | Setting range: 0x0000–0xFFFF | 0xFFFF | ☉ |

| Function code | Name | Description | Default | Modify |
|---------------|--|------------------------------|---------|--------|
| P16.52 | User-defined write address 11 | Setting range: 0x0000–0xFFFF | 0xFFFF | ☉ |
| P16.53 | Local address corresponding to user-defined write address 11 | Setting range: 0x0000–0xFFFF | 0xFFFF | ☉ |
| P16.54 | User-defined write address 12 | Setting range: 0x0000–0xFFFF | 0xFFFF | ☉ |
| P16.55 | Local address corresponding to user-defined write address 12 | Setting range: 0x0000–0xFFFF | 0xFFFF | ☉ |
| P16.56 | User-defined write address 13 | Setting range: 0x0000–0xFFFF | 0xFFFF | ☉ |
| P16.57 | Local address corresponding to user-defined write address 13 | Setting range: 0x0000–0xFFFF | 0xFFFF | ☉ |
| P16.58 | User-defined write address 14 | Setting range: 0x0000–0xFFFF | 0xFFFF | ☉ |
| P16.59 | Local address corresponding to user-defined write address 14 | Setting range: 0x0000–0xFFFF | 0xFFFF | ☉ |

| Function code | Name | Description | Default | Modify |
|---------------|--|------------------------------|---------|--------|
| P16.60 | User-defined write address 15 | Setting range: 0x0000–0xFFFF | 0xFFFF | ☉ |
| P16.61 | Local address corresponding to user-defined write address 15 | Setting range: 0x0000–0xFFFF | 0xFFFF | ☉ |
| P16.62 | User-defined write address 16 | Setting range: 0x0000–0xFFFF | 0xFFFF | ☉ |
| P16.63 | Local address corresponding to user-defined write address 16 | Setting range: 0x0000–0xFFFF | 0xFFFF | ☉ |

Group P17—Status viewing

| Function code | Name | Description | Default | Modify |
|---------------|--------------------------|---|---------|--------|
| P17.00 | Set frequency | Displays the present set frequency of the VFD. Setting range: 0.00Hz–P00.03 | 0.00 | ● |
| P17.01 | Output frequency | Displays the present output frequency of the VFD. Setting range: 0.00Hz–P00.03 | 0.00 | ● |
| P17.02 | Ramp reference frequency | Displays the present ramp reference frequency of the VFD. Setting range: 0.00Hz–P00.03 | 0.00 | ● |
| P17.03 | Output voltage | Displays the present output voltage of the VFD. Setting range: 0–1200V | 0 | ● |
| P17.04 | Output current | Displays the valid value of present output current of the VFD. Setting range: 0.00–500.00A | 0.00 | ● |

| Function code | Name | Description | Default | Modify |
|---------------|-------------------------------|---|---------|--------|
| P17.05 | Motor rotation speed | Displays the present motor rotation speed. Setting range: 0–65535RPM | 0 | ● |
| P17.06 | Torque current | Displays the present torque current of the VFD. Setting range: -300.00–300.00A | 0.00 | ● |
| P17.07 | Exciting current | Displays the present exciting current of the VFD. Setting range: -300.00–300.00A | 0.00 | ● |
| P17.08 | Motor power | Displays the present motor power. 100% corresponds to the motor rated power. Setting range: -300.0%–300.0% (of the motor rated frequency) | 0.0 | ● |
| P17.09 | Motor output torque | Displays the present output torque of the VFD. 100% corresponds to the motor rated torque. Setting range: -250.0%–250.0% | 0.0 | ● |
| P17.10 | Estimated motor frequency | Used to indicate the estimated motor rotor frequency under the open-loop vector condition. Setting range: 0.00–600.00Hz | 0.00 | ● |
| P17.11 | DC bus voltage | Displays the present DC bus voltage of the VFD. Setting range: 0.0–2000.0V | 0.0 | ● |
| P17.12 | Digital input terminal state | Displays the present digital input terminal state of the VFD. Setting range: 0x000–0x7FF Bit 0: DI1 Bit 1: DI2 Bit 2: DI3 Bit 3: DI4 Bit 4: DI5 Bit 5: DI6 Bit 6: DI7 Bit 7: DI8 Bit 8: Reserved Bit 9: Reserved Bit 10: HDI1 | 0x000 | ● |
| P17.13 | Digital output terminal state | Displays the present digital output terminal state of the VFD. Setting range: 0x00–0x1F Bit 0: Reserved | 0x00 | ● |

| Function code | Name | Description | Default | Modify |
|---------------|--------------------------|---|-------------------------|--------|
| | | Bit 1: Reserved Bit 2: Reserved Bit 3: HDO1 Bit 4: RO1 | | |
| P17.14 | Digital adjustment value | Displays the adjustment on the VFD through the UP/DOWN terminal. Setting range: 0.00–600.00Hz | 0.00 | ● |
| P17.15 | Torque reference value | Indicates the percentage of the rated torque of the present motor, displaying the torque reference. Setting range: -300.0%–300.0% (of the motor rated current) | 0.0 | ● |
| P17.16 | Linear speed | Setting range: 0–65535 | 0 | ● |
| P17.17 | Drive board type | Setting range: 0x0000–0xFFFF Bit0–bit3: Reserved Bit4–bit11: Chip type and manufacturer 0x00: DSP(TI) 0x01–0xFF: Reserved Bit 12–Bit 15: Reserved 0x0–0xF: Reserved | Model depended (0x0000) | ● |
| P17.18 | Count value | Setting range: 0–65535 | 0 | ● |
| P17.19 | AI1 input voltage | Displays the AI1 input signal. When AI1 input is the current input, 0/20mA corresponds to 0/10.00V. Setting range: 0.00–10.00V | 0.00 | ● |
| P17.20 | AI2 input voltage | Displays the AI2 input signal. When AI2 input is the current input, 0/20mA corresponds to -10.00/10.00V. Setting range: 0.00V–10.00V | 0.00 | ● |
| P17.21 | AI3 input voltage | Displays the AI3 input signal. Setting range: 0.00V–10.00V | 0.00 | ● |
| P17.23 | HDI1 input frequency | Displays the HDIA input frequency. Setting range: 0.000–50.000kHz | 0.000 | ● |
| P17.25 | PID reference value | Displays the PID reference value. Setting range: -100.0%–100.0% | 0.0 | ● |
| P17.26 | PID feedback value | Displays the PID feedback value. Setting range: -100.0%–100.0% | 0.0 | ● |

| Function code | Name | Description | Default | Modify |
|---------------|-----------------------------|--|---------|--------|
| P17.27 | Motor power factor | Displays the power factor of the present motor. Setting range: -1.00~1.00 | 0.00 | ● |
| P17.28 | Duration of this run | Displays the duration of this run of the VFD. Setting range: 0~65535min | 0 | ● |
| P17.29 | Present step of simple PLC | Displays the present step of the simple PLC function. Setting range: 0~15 | 0 | ● |
| P17.30 | Motor ASR controller Output | Displays the ASR controller output value as a percentage relative to the rated motor torque under the vector control mode. Setting range: -300.0%~300.0% | 0.0 | ● |
| P17.31 | Open-loop SM pole Angle | Displays the initial identification angle of SM. Setting range: 0.0~360.0 | 0.0 | ● |
| P17.32 | Phase compensation of SM | Displays the phase compensation of SM. Setting range: -180.0~180.0 | 0.0 | ● |
| P17.34 | Motor flux linkage | 0.0~200.0% | 0.0 | ● |
| P17.35 | Exciting current reference | Displays the exciting current reference value under the vector control mode. Setting range: -300.00~300.00A | 0.00 | ● |
| P17.36 | Torque current reference | Displays the torque current reference value under the vector control mode. Setting range: -300.00~300.00A | 0.00 | ● |
| P17.38 | Output torque | Displays the output torque value. During forward running, the positive value is the motoring state while the negative value is generating state. During reverse running, the positive value is the generating state while the negative value is the motoring state. Setting range: -3000.0~3000.0Nm | 0.0 | ● |
| P17.39 | Motor overload count value | Setting range: 0~65535 | 0 | ● |

| Function code | Name | Description | Default | Modify |
|---------------|--|--|---------|--------|
| P17.40 | Process PID output | Setting range: -100.0%–100.0% | 0.0 | ● |
| P17.41 | Parameter download error Function code | Setting range: 0.00–99.00 | 0.00 | ● |
| P17.42 | Motor control mode | Setting range: 0x000–0x122 Ones place: Control mode 0: Vector 0 1: Vector 1 2: V/F control Tens place: Control status 0: Speed control 1: Torque control 2: Reserved Hundreds place: Motor number 0: Motor 1 1: Motor 2 | 0x000 | ● |
| P17.43 | Electromotive torque upper limit | Setting range: 0.0–300.0% (of the motor rated current) | 0.0 | ● |
| P17.44 | Braking torque upper limit | Setting range: 0.0–300.0% (of the motor rated current) | 0.0 | ● |
| P17.45 | Forward rotation upper-limit frequency in torque control | Setting range: 0.00–600.00Hz | 0.00 | ● |
| P17.46 | Reverse rotation upper-limit frequency in torque control | Setting range: 0.00–600.00Hz | 0.00 | ● |

| Function code | Name | Description | Default | Modify |
|---------------|-------------------------------|--------------------------------|---------|--------|
| P17.47 | Inertia compensation torque | Setting range: -100.0%~100.0% | 0.0 | ● |
| P17.48 | Friction compensation torque | Setting range: -100.0%~100.0% | 0.0 | ● |
| P17.49 | Motor pole pairs | Setting range: 0~65535 | 0 | ● |
| P17.50 | VFD overload count value | Setting range: 0~65535 | 0 | ● |
| P17.51 | Frequency set by A source | Setting range: 0.00~600.00Hz | 0.00 | ● |
| P17.52 | Frequency set by B source | Setting range: 0.00~600.00Hz | 0.00 | ● |
| P17.53 | PID proportional output | Setting range: -100.0%~100.0% | 0.0 | ● |
| P17.54 | PID integral output | Setting range: -100.0%~100.0% | 0.0 | ● |
| P17.55 | PID differential output | Setting range: -100.0%~100.0% | 0.0 | ● |
| P17.56 | PID present proportional gain | Setting range: 0.00~100.00 | 0.00 | ● |
| P17.57 | PID present integral gain | Setting range: 0.00~10.00s | 0.00 | ● |
| P17.58 | PID present differential time | Setting range: 0.00~10.00s | 0.00 | ● |
| P17.59 | Actual carrier frequency | Setting range: 0.000~15.000kHz | 0.000 | ● |

| Function code | Name | Description | Default | Modify |
|---------------|-----------------------|--|---------|--------|
| P17.65 | VFD status word 3 | Setting range: 0x0000–0xFFFF Bit 0: Running protection flag Bit 1: Running Bit 2: Running direction (1=REV, 0=FWD) Bit 3: Jogging Bit 4: Alarming Bit 5: In fault Bit 6: Running paused Bit 7: In sleep Bit 8: In PoFF state Bit 9: Undervoltage due to transient power loss Bit 10: Overvoltage stall Bit 11: Pre-exciting Bit 12: DC braking Bit 13: Identifying parameters Bit 14: Flux weakening (reserved) Bit 15: Reserved | 0x0000 | ● |
| P17.66 | CPU load rate | Setting range: 0.0–100.0% | 0.0 | ● |
| P17.67 | 8k test duration | Setting range: 0–65535 | 0 | ● |
| P17.68 | Drive board attribute | Setting range: 0x0000–0xFFFF Bit 0–Bit 3: Power range identifying Bit 4: 1PH/3PH identifying 0: 3PH 1: 1PH Bit 5–Bit 15: Reserved | 0x0000 | ● |

Group P23—Communication expansion function group 1

| Function code | Name | Description | Default | Modify |
|---------------|---------------|--|---------|--------|
| P23.02 | Received PZD2 | Setting range: 0–31 0: Invalid | 0 | ○ |
| P23.03 | Received PZD3 | 1: Set frequency (0–Fmax, unit: 0.01Hz) 2: PID reference (-1000–1000, in which 1000 | 0 | ○ |

| Function code | Name | Description | Default | Modify |
|---------------|----------------|--|---------|--------|
| P23.04 | Received PZD4 | corresponds to 100.0%) 3: PID feedback (-1000–1000, in which 1000 | 0 | ○ |
| P23.05 | Received PZD5 | corresponds to 100.0%) 4: Torque setting (-3000–+3000, in which 1000 | 0 | ○ |
| P23.06 | Received PZD6 | corresponds to 100.0% of the motor rated current) | 0 | ○ |
| P23.07 | Received PZD7 | 5: Setting of the upper limit of forward running frequency (0–Fmax, unit: 0.01Hz) | 0 | ○ |
| P23.08 | Received PZD8 | 6: Setting of the upper limit of reverse running frequency (0–Fmax, unit: 0.01Hz) | 0 | ○ |
| P23.09 | Received PZD9 | 7: Upper limit of the electromotive torque (0–3000, in which 1000 corresponds to 100.0% of the motor rated current) | 0 | ○ |
| P23.10 | Received PZD10 | 8: Upper limit of braking torque (0–3000, in | 0 | ○ |
| P23.11 | Received PZD11 | which 1000 corresponds to 100% of the motor rated current) | 0 | ○ |
| P23.12 | Received PZD12 | 9: Virtual input terminal command (0x000–0x7FF) 10: Virtual output terminal command (0x000–0x01F) 11: Voltage setting special for V/F separation (0–1000, in which 1000 corresponds to 100.0% of the motor rated voltage) 12: AO setting 1 (0–1000, in which 1000 corresponds to 100.0%) 13: AO setting 2 (-1000–1000, in which 1000 corresponds to 100.0%) 14–18: Reserved 19: Function parameter mapping (PZD2–PZD12 correspond to P14.49–P14.59) 20–31: Reserved | 0 | ○ |
| P23.13 | Sent PZD2 | Setting range: 0–32 | 0 | ○ |
| P23.14 | Sent PZD3 | 0: Invalid | 0 | ○ |
| P23.15 | Sent PZD4 | 1: Running frequency (×100, Hz) | 0 | ○ |
| P23.16 | Sent PZD5 | 2: Set frequency (×100, Hz) | 0 | ○ |
| P23.17 | Sent PZD6 | 3: Bus voltage (×10, V) | 0 | ○ |
| P23.18 | Sent PZD7 | 4: Output voltage (×1, V) | 0 | ○ |

| Function code | Name | Description | Default | Modify |
|---------------|------------|---|---------|-----------------------|
| P23.19 | Sent PZD8 | 5: Output current (×100, A) | 0 | <input type="radio"/> |
| P23.20 | Sent PZD9 | 6: Actual output torque (×10, %) | 0 | <input type="radio"/> |
| P23.21 | Sent PZD10 | 7: Actual output power (×10, %) | 0 | <input type="radio"/> |
| P23.22 | Sent PZD11 | 8: Rotation speed of running (×1, RPM) | 0 | <input type="radio"/> |
| P23.23 | Sent PZD12 | 9: Linear speed of running (×1, m/s) 10: Ramp reference frequency (×100, Hz) 11: Fault code 12: AI1 input (×100, V) 13: AI2 input (×100, V) 14: AI3 input (×100, V) 15: Reserved 16: HDI1 frequency value (×100, kHz) 17: Reserved 18: Terminal input state 19: Terminal output status 20: PID reference (×100, %) 21: PID feedback (×100, %) 22–26: Reserved 27: VFD status word 2 28–31: Reserved 32: Function parameter mapping (PZD2–PZD12 correspond to P14.60–P14.70) | 0 | <input type="radio"/> |

Group P24—Communication expansion function group 2

| Function code | Name | Description | Default | Modify |
|---------------|-----------------------------------|---|---------|----------------------------------|
| P24.00 | Expansion card protocol selection | Setting range: 0–15 0: PROFINET 1: EtherCAT 2: Reserved 3: EtherNet IP 4: Modbus TCP 5: EtherNet UDP 6: PROFINET + EtherNet UDP 7: EtherCAT + EtherNet UDP 8–14: Reserved 15: No communication expansion card | 0 | <input checked="" type="radio"/> |

| Function code | Name | Description | Default | Modify |
|---------------|---|------------------------------|---------|--------|
| P24.02 | Ethernet monitoring card IP address 1 | Setting range: 0-255 | 192 | ☉ |
| P24.03 | Ethernet monitoring card IP address 2 | Setting range: 0-255 | 168 | ☉ |
| P24.04 | Ethernet monitoring card IP address 3 | Setting range: 0-255 | 0 | ☉ |
| P24.05 | Ethernet monitoring card IP address 4 | Setting range: 0-255 | 1 | ☉ |
| P24.06 | Ethernet monitoring card subnet mask 1 | Setting range: 0-255 | 255 | ☉ |
| P24.07 | Ethernet monitoring card subnet mask 2 | Setting range: 0-255 | 255 | ☉ |
| P24.08 | Ethernet monitoring card subnet mask 3 | Setting range: 0-255 | 255 | ☉ |
| P24.09 | Ethernet monitoring card subnet mask 4 | Setting range: 0-255 | 0 | ☉ |
| P24.14 | Ethernet card monitoring variable address 1 | Setting range: 0x0000-0xFFFF | 0x0000 | ○ |

| Function code | Name | Description | Default | Modify |
|---------------|---|--|---------|-----------------------|
| P24.15 | Ethernet card monitoring variable address 2 | Setting range: 0x0000–0xFFFF | 0x0000 | <input type="radio"/> |
| P24.16 | Ethernet card monitoring variable address 3 | Setting range: 0x0000–0xFFFF | 0x0000 | <input type="radio"/> |
| P24.17 | Ethernet card monitoring variable address 4 | Setting range: 0x0000–0xFFFF | 0x0000 | <input type="radio"/> |
| P24.18 | Ethernet card monitoring variable address 5 | Setting range: 0x0000–0xFFFF | 0x0000 | <input type="radio"/> |
| P24.19 | Ethernet card monitoring variable address 6 | Setting range: 0x0000–0xFFFF | 0x0000 | <input type="radio"/> |
| P24.20 | Ethernet card monitoring variable address 7 | Setting range: 0x0000–0xFFFF | 0x0000 | <input type="radio"/> |
| P24.21 | Ethernet card monitoring variable address 8 | Setting range: 0x0000–0xFFFF | 0x0000 | <input type="radio"/> |
| P24.24 | Time to identify expansion card | Setting range: 0.0–600.0s Note: The function is invalid when the value is 0.0. | 0.0 | <input type="radio"/> |

| Function code | Name | Description | Default | Modify |
|---------------|---|--|---------|----------------------------------|
| P24.27 | Expansion card communication timeout time | Setting range: 0.0–600.0s ⚡ Note: The function is invalid when the value is 0.0. | 0.0 | <input type="radio"/> |
| P24.30 | EtherCAT communication timeout time | Setting range: 0.0–60.0s ⚡ Note: The function is invalid when the value is 0.0. | 5.0 | <input type="radio"/> |
| P24.31 | PROFINET communication timeout time | Setting range: 0.0–60.0s ⚡ Note: The function is invalid when the value is 0.0. | 5.0 | <input type="radio"/> |
| P24.32 | EtherNet IP communication timeout time | Setting range: 0.0–60.0s ⚡ Note: The function is invalid when the value is 0.0. | 5.0 | <input type="radio"/> |
| P24.34 | Modbus TCP communication timeout time | Setting range: 0.0–60.0s ⚡ Note: The function is invalid when the value is 0.0. | 5.0 | <input type="radio"/> |
| P24.37 | Industrial Ethernet communication card IP address 1 | Setting range: 0–255 | 192 | <input checked="" type="radio"/> |
| P24.38 | Industrial Ethernet communication card IP address 2 | Setting range: 0–255 | 168 | <input checked="" type="radio"/> |
| P24.39 | Industrial Ethernet communication card IP address 3 | Setting range: 0–255 | 0 | <input checked="" type="radio"/> |

| Function code | Name | Description | Default | Modify |
|---------------|--|--|---------|----------------------------------|
| P24.40 | Industrial Ethernet communication card IP address 4 | Setting range: 0–255 | 20 | <input checked="" type="radio"/> |
| P24.41 | Industrial Ethernet communication card subnet mask 1 | Setting range: 0–255 | 255 | <input checked="" type="radio"/> |
| P24.42 | Industrial Ethernet communication card subnet mask 2 | Setting range: 0–255 | 255 | <input checked="" type="radio"/> |
| P24.43 | Industrial Ethernet communication card subnet mask 3 | Setting range: 0–255 | 255 | <input checked="" type="radio"/> |
| P24.44 | Industrial Ethernet communication card subnet mask 4 | Setting range: 0–255 | 0 | <input checked="" type="radio"/> |
| P24.49 | Saving EtherCAT written function codes | Setting range: 0–1 0: No 1: Yes | 0 | <input type="radio"/> |
| P24.50 | EtherCAT DC synchronization cycle | Setting range: 0–5 0: Reserved 1: Reserved 2: 1ms | 0 | <input type="radio"/> |

| Function code | Name | Description | Default | Modify |
|---------------|-----------------------------|------------------------------|---------|--------|
| | | 3: 2ms 4: 4ms 5: 8ms | | |
| P24.51 | EtherCAT slave node address | Setting range: 0x0000–0xFFFF | 0xFFFF | ○ |

Group P29—Expansion card status viewing

| Function code | Name | Description | Default | Modify |
|---------------|---|---|---------|--------|
| P29.00 | Expansion card type | Setting range: 0–63 0: No card 1–35: Reserved 36: All-in-one expansion card—PROFINET communication card 37–40: Reserved 41: All-in-one expansion card—EtherCAT communication card 42: Reserved 43: All-in-one expansion card—EtherNet IP communication card 44: All-in-one expansion card—Modbus TCP communication card 45: All-in-one expansion card—Ethernet communication card 46: All-in-one expansion card—PROFINET + Ethernet communication card 47: All-in-one expansion card—EtherCAT + Ethernet communication card 48–63: Reserved | 0 | ● |
| P29.03 | Expansion card software version | Setting range: 0.00–655.35 | 0.00 | ● |
| P29.17 | Present value of Ethernet monitoring variable 1 | Setting range: 0–65535 ⚡ Note: Monitoring variables 1–4 are used for the control board. | 0 | ● |

| Function code | Name | Description | Default | Modify |
|---------------|---|--|---------|--------|
| P29.18 | Present value of Ethernet monitoring variable 2 | Setting range: 0–65535 | 0 | ● |
| P29.19 | Present value of Ethernet monitoring variable 3 | Setting range: 0–65535 | 0 | ● |
| P29.20 | Present value of Ethernet monitoring variable 4 | Setting range: 0–65535 | 0 | ● |
| P29.21 | Present value of Ethernet monitoring variable 5 | Setting range: 0–65535 ⚡ Note: Monitoring variable 5–8 are used for the drive board. | 0 | ● |
| P29.22 | Present value of Ethernet monitoring variable 6 | Setting range: 0–65535 | 0 | ● |
| P29.23 | Present value of Ethernet monitoring variable 7 | Setting range: 0–65535 | 0 | ● |
| P29.24 | Present value of Ethernet monitoring variable 8 | Setting range: 0–65535 | 0 | ● |
| P29.32 | EtherCAT control word | Setting range: 0x0000–0xFFFF | 0x0000 | ● |

| Function code | Name | Description | Default | Modify |
|---------------|----------------------|------------------------------|---------|--------|
| P29.33 | EtherCAT status word | Setting range: 0x0000–0xFFFF | 0x0000 | ● |

Group P34—Parameters of motor 2

| Function code | Name | Description | Default | Modify |
|---------------|----------------------------|---|----------------|--------|
| P34.00 | Type of motor 2 | Setting range: 0–1 0: Asynchronous motor (AM) 1: Permanent magnet synchronous motor | 0 | ☉ |
| P34.01 | Rated power of AM 2 | Setting range: 0.1–3000.0kW | Model depended | ☉ |
| P34.02 | Rated frequency of AM 2 | Setting range: 0.01Hz–P00.03 | 50.00 | ☉ |
| P34.03 | Rated speed of AM 2 | Setting range: 1–60000RPM | Model depended | ☉ |
| P34.04 | Rated voltage of AM 2 | Setting range: 0–1200V | Model depended | ☉ |
| P34.05 | Rated current of AM 2 | Setting range: 0.08–600.00A | Model depended | ☉ |
| P34.06 | Stator resistance of AM 2 | Setting range: 0.001–65.535Ω | Model depended | ○ |
| P34.07 | Rotor resistance of AM 2 | Setting range: 0.001–65.535Ω | Model depended | ○ |
| P34.08 | Leakage inductance of AM 2 | Setting range: 0.1–6553.5mH | Model depended | ○ |
| P34.09 | Mutual inductance of AM 2 | Setting range: 0.1–6553.5mH | Model depended | ○ |
| P34.10 | No-load current of AM 2 | Setting range: 0.01–655.35A | Model depended | ○ |

| Function code | Name | Description | Default | Modify |
|---------------|--|------------------------------|----------------|----------------------------------|
| P34.11 | Magnetic saturation coefficient 1 of iron core of AM 2 | Setting range: 0.0–100.0% | 80.0 | <input type="radio"/> |
| P34.12 | Magnetic saturation coefficient 2 of iron core of AM 2 | Setting range: 0.0–100.0% | 68.0 | <input type="radio"/> |
| P34.13 | Magnetic saturation coefficient 3 of iron core of AM 2 | Setting range: 0.0–100.0% | 57.0 | <input type="radio"/> |
| P34.14 | Magnetic saturation coefficient 4 of iron core of AM 2 | Setting range: 0.0–100.0% | 40.0 | <input type="radio"/> |
| P34.15 | Rated power of SM 2 | Setting range: 0.1–3000.0kW | Model depended | <input checked="" type="radio"/> |
| P34.16 | Rated frequency of SM 2 | Setting range: 0.01Hz–P00.03 | 50.00 | <input checked="" type="radio"/> |
| P34.17 | Number of pole pairs of SM 2 | Setting range: 1–128 | 2 | <input checked="" type="radio"/> |
| P34.18 | Rated voltage of SM 2 | Setting range: 0–1200V | Model depended | <input checked="" type="radio"/> |
| P34.19 | Rated current of SM 2 | Setting range: 0.08–600.00A | Model depended | <input checked="" type="radio"/> |
| P34.20 | Stator resistance of SM 2 | Setting range: 0.001–65.535Ω | Model depended | <input type="radio"/> |

| Function code | Name | Description | Default | Modify |
|---------------|---|--|----------------|----------------------------------|
| P34.21 | Direct-axis inductance of SM 2 | Setting range: 0.01–655.35mH | Model depended | <input type="radio"/> |
| P34.22 | Quadrature-axis inductance of SM 2 | Setting range: 0.01–655.35mH | Model depended | <input type="radio"/> |
| P34.23 | Counter-emf constant of SM 2 | Setting range: 0–10000 | 300 | <input type="radio"/> |
| P34.24 | Initial pole position of SM 2 | Setting range: 0x0000–0xFFFF | 0x0000 | <input checked="" type="radio"/> |
| P34.25 | Frequency percentage for SM 2 counter-emf identifying | Setting range: 5.0%–100.0% | 60 | <input checked="" type="radio"/> |
| P34.26 | Overload protection selection of motor 2 | Setting range: 0–2 0: No protection 1: Common motor (with low-speed compensation) As the cooling effect of a common motor is degraded at low speed running, the corresponding electronic thermal protection value needs to be adjusted properly, the low compensation indicates lowering the overload protection threshold of the motor whose running frequency is lower than 30Hz. 2: Frequency-variable motor (without low-speed compensation) The heat dissipation function for a variable-frequency motor is not impacted by the rotation speed, and therefore it is not necessary to adjust the protection value at low speed running. | 2 | <input checked="" type="radio"/> |

| Function code | Name | Description | Default | Modify |
|---------------|--|---|---------|----------------------------------|
| P34.27 | Overload protection coefficient of motor 2 | Specifies the motor overload protection coefficient. A small motor overload protection coefficient indicates a great overload multiplication (M). When M=116%, protection is performed after motor overload lasts for 1 hour; when M=150%, protection is performed after motor overload lasts for 12 minutes; when M=180%, protection is performed after motor overload lasts for 5 minutes; when M=200%, protection is performed after motor overload lasts for 60 seconds; and when $M \geq 400\%$, protection is performed immediately. Setting range: 20.0%–150.0% | 100.0 | <input type="radio"/> |
| P34.28 | Power display calibration coefficient of motor 2 | Used to adjust the power display value of motor 1. However, it does not affect the control performance of the VFD. Setting range: 0.00–3.00 | 1.00 | <input type="radio"/> |
| P34.29 | Parameter display selection of motor 2 | Setting range: 0–1 0: Display by motor type. In this mode, only parameters related to the present motor type are displayed. 1: Display all. In this mode, all the motor parameters are displayed. | 0 | <input type="radio"/> |
| P34.30 | System inertia of motor 2 | Setting range: 0.001–65.535kg · m ² | 0.001 | <input type="radio"/> |
| P34.31 | Parameter model calculation of motor 2 | Setting range: 0–1 0: Disable 1: Enable | 0 | <input checked="" type="radio"/> |
| P34.32 | Power factor of AM 2 | Setting range: 0.00–1.00 | 0.85 | <input type="radio"/> |
| P34.33 | High word of rated speed of AM 2 | Setting range: 0–3010kRPM | 0 | <input checked="" type="radio"/> |

| Function code | Name | Description | Default | Modify |
|---------------|--|---------------------------|---------|-----------------------|
| P34.34 | AM2 iron core saturation coefficient 1 | Setting range: 0.0–200.0% | 125.0 | <input type="radio"/> |
| P34.35 | Iron core saturation coefficient 2 of AM 2 | Setting range: 0.0–200.0% | 125.0 | <input type="radio"/> |
| P34.36 | AM2 mutual inductance saturation coefficient 1 | Setting range: 0.0–200.0% | 88.0 | <input type="radio"/> |
| P34.37 | Mutual inductance saturation coefficient 2 of AM 2 | Setting range: 0.0–200.0% | 88.0 | <input type="radio"/> |
| P34.38 | Mutual inductance flux weakening coefficient 1 of AM 2 | Setting range: 0.0–200.0% | 112.5 | <input type="radio"/> |
| P34.39 | Mutual inductance flux weakening coefficient 2 of AM 2 | Setting range: 0.0–200.0% | 117.6 | <input type="radio"/> |
| P34.40 | Mutual inductance flux weakening coefficient 3 of AM 2 | Setting range: 0.0–200.0% | 122.8 | <input type="radio"/> |

| Function code | Name | Description | Default | Modify |
|---------------|--|---------------------------|---------|-----------------------|
| P34.41 | Mutual inductance flux weakening coefficient 4 of AM 2 | Setting range: 0.0–200.0% | 125.0 | <input type="radio"/> |

Group P35—Vector control of motor 2

| Function code | Name | Description | Default | Modify |
|---------------|---|--|---------|-----------------------|
| P35.00 | Speed-loop proportional gain 1 of motor 2 | Setting range: 0.0–200.0 ⚡ Note: Applicable only to vector control mode. | 20.0 | <input type="radio"/> |
| P35.01 | Speed-loop integral time 1 of motor 2 | Setting range: 0.000–10.000s ⚡ Note: Applicable only to vector control mode. | 0.200 | <input type="radio"/> |
| P35.02 | Motor 2 switching low-point frequency | Setting range: 0.00Hz–P03.05 ⚡ Note: Applicable only to vector control mode. | 5.00 | <input type="radio"/> |
| P35.03 | Speed-loop proportional gain 2 of motor 2 | Setting range: 0.0–200.0 ⚡ Note: Applicable only to vector control mode. | 20.0 | <input type="radio"/> |
| P35.04 | Speed-loop integral time 2 of motor 2 | Setting range: 0.000–10.000s ⚡ Note: Applicable only to vector control mode. | 0.200 | <input type="radio"/> |
| P35.05 | Switching high-point frequency of motor 2 | Setting range: P03.02–P00.03(Hz) ⚡ Note: Applicable only to vector control mode. | 10.00 | <input type="radio"/> |
| P35.06 | Speed-loop output filter of motor 2 | Setting range: 0–8 (corresponding to 0–2 ⁸ /10ms) | 0 | <input type="radio"/> |

| Function code | Name | Description | Default | Modify |
|---------------|---|--|---------|-----------------------|
| P35.07 | Electromotive slip compensation coefficient of vector control for motor 2 | Slip compensation coefficient is used to adjust the slip frequency of the vector control and improve the speed control accuracy of the system. Adjusting the parameter properly can control the speed steady-state error. Setting range: 50%–200% | 100 | <input type="radio"/> |
| P35.08 | Braking slip compensation coefficient of vector control for motor 2 | Slip compensation coefficient is used to adjust the slip frequency of the vector control and improve the speed control accuracy of the system. Adjusting the parameter properly can control the speed steady-state error. Setting range: 50%–200% | 100 | <input type="radio"/> |
| P35.11 | Torque setting method selection of motor 2 | Setting range: 0–15 0: Set by P35.12 1: AI1 2: AI2 3: AI3 4: Reserved 5: High-speed pulse HDI1 6–7: Reserved 8: Multi-step speed running 9: Reserved 10: Modbus/Modbus TCP communication 11: Reserved 12: Ethernet communication 13: Reserved 14: EtherCAT/PROFINET/EtherNet IP communication 15: Reserved Note: 100% corresponds to the motor rated current. | 0 | <input type="radio"/> |
| P35.12 | Torque set through keypad of motor 2 | Setting range: -300.0%–300.0% Note: The value is relative to the motor rated current. | 20.0 | <input type="radio"/> |

| Function code | Name | Description | Default | Modify |
|---------------|---|--|---------|-----------------------|
| P35.13 | Torque reference filter time of motor 2 | Setting range: 0.000–10.000s | 0.010 | <input type="radio"/> |
| P35.14 | Setting source of forward rotation frequency upper limit in torque control of motor 2 | Setting range: 0–15 0: Set by P35.16 1: AI1 2: AI2 3: AI3 4: Reserved 5: High-speed pulse HDI1 6–7: Reserved 8: Multi-step speed running 9: Reserved 10: Modbus/Modbus TCP communication 11: Reserved 12: Ethernet communication 13: Reserved 14: EtherCAT/PROFINET/EtherNet IP communication 15: Reserved ⚡ Note: For setting 1 and above, 100% corresponds to the max. frequency. | 0 | <input type="radio"/> |
| P35.15 | Setting source of reverse rotation frequency upper limit in torque control of motor 2 | Setting range: 0–6 0: Set by P35.17 1: AI1 2: AI2 3: AI3 4: Reserved 5: High-speed pulse HDI1 6–7: Reserved 8: Multi-step speed running 9: Reserved 10: Modbus/Modbus TCP communication 11: Reserved 12: Ethernet communication 13: Reserved 14: EtherCAT/PROFINET/EtherNet IP communication | 0 | <input type="radio"/> |

| Function code | Name | Description | Default | Modify |
|---------------|--|--|---------|-----------------------|
| | | 15: Reserved ⚡Note: For setting 1 and above, 100% corresponds to the max. frequency. | | |
| P35.16 | Forward rotation frequency upper limit set through keypad in torque control of motor 2 | Specifies the frequency limit when P03.14=0. Setting range: 0.00Hz-P00.03 | 50.00 | <input type="radio"/> |
| P35.17 | Reverse rotation frequency upper limit set through keypad in torque control of motor 2 | Specifies the frequency limit when P35.15=0. Setting range: 0.00Hz-P00.03 | 50.00 | <input type="radio"/> |
| P35.18 | Setting source of electromagnetic torque upper limit for motor 2 | Setting range: 0-15 0: Set by P35.20 1: AI1 2: AI2 3: AI3 4: Reserved 5: High-speed pulse HDI1 6-9: Reserved 10: Modbus/Modbus TCP communication 11: Reserved 12: Ethernet communication 13: Reserved 14: EtherCAT/PROFINET/EtherNet IP communication 15: Reserved ⚡Note: 100% corresponds to the motor rated current. | 0 | <input type="radio"/> |

| Function code | Name | Description | Default | Modify |
|---------------|---|--|---------|-----------------------|
| P35.19 | Setting source of braking torque upper limit for motor 2 | Setting range: 0–15 0: Set by P35.21 1: AI1 2: AI2 3: AI3 4: Reserved 5: High-speed pulse HDI1 6–9: Reserved 10: Modbus/Modbus TCP communication 11: Reserved 12: Ethernet communication 13: Reserved 14: EtherCAT/PROFINET/EtherNet IP communication 15: Reserved Note: 100% corresponds to the motor rated current. | 0 | <input type="radio"/> |
| P35.20 | Electromotive torque upper limit set through keypad for motor 2 | Specifies the torque limit when P03.18=0. Setting range: 0.0–300.0% Note: The value is relative to the motor rated current. | 180.0 | <input type="radio"/> |
| P35.21 | Braking torque upper limit set through keypad for motor 2 | Specifies the torque limit when P03.19=0. Setting range: 0.0–300.0% Note: The value is relative to the motor rated current. | 180.0 | <input type="radio"/> |
| P35.22 | Weakening coefficient in constant power zone for motor 2 | Used when the AM is in flux-weakening control. Setting range: 0.0–200.0% | 100.0 | <input type="radio"/> |

| Function code | Name | Description | Default | Modify |
|---------------|---|--|---------|-----------------------|
| P35.23 | Lowest weakening point in constant power zone for motor 2 | Setting range: 5%–100% | 5 | <input type="radio"/> |
| P35.24 | Max. voltage limit on motor 2 | Specifies the max. VFD output voltage, which is a percentage of the motor rated voltage. Set the value according to onsite conditions. Setting range: 0.0–120.0% | 100.0 | <input type="radio"/> |
| P35.25 | Pre-exciting time of motor 2 | Specifies the pre-exciting time. Pre-exciting is performed for the motor when the VFD starts up. A magnetic field is built up inside the motor to improve the torque performance during the start process. Setting range: 0.000–10.000s Note: Pre-excitation can improve the start-up capability of AM with loads. For an AM, set 0 to disable the pre-excitation process. For an SM, if P13.01 is set to an enabling option, the pre-excitation process is directly skipped. | 0.300 | <input type="radio"/> |
| P35.26 | Flux-weakening proportional gain of motor 2 | Setting range: 0–8000 | 1000 | <input type="radio"/> |
| P35.27 | Speed display selection in vector control for motor 2 | Setting range: 0–1 0: Display the actual value 1: Display the set value | 0 | <input type="radio"/> |
| P35.28 | Static friction compensation coefficient of motor 2 | Setting range: 0.0–100.0% | 0.0 | <input type="radio"/> |

| Function code | Name | Description | Default | Modify |
|---------------|--|--|---------|-----------------------|
| P35.29 | Static friction corresponding frequency point of motor 2 | Setting range: 0.50Hz–P35.31 | 1.00 | <input type="radio"/> |
| P35.30 | High speed friction compensation coefficient of motor 2 | Setting range: 0.0–100.0% | 0.0 | <input type="radio"/> |
| P35.31 | High speed friction corresponding frequency point of motor 2 | Setting range: P35.29–P00.03(Hz) | 50.00 | <input type="radio"/> |
| P35.32 | Enabling torque control of motor 2 | Setting range: 0–1 0: Disable 1: Enable | 0 | <input type="radio"/> |
| P35.33 | Flux-weakening integral gain of motor 2 | Setting range: 0.0–300.0% | 30.0 | <input type="radio"/> |
| P35.35 | Control mode optimization selection of motor 2 | Setting range: 0x0000–0x1111 Ones place: Torque command selection 0: Torque current reference 1: Torque current reference Tens place: Reserved Hundreds place: indicates whether to enable speed-loop integral separation 0: Disable 1: Enable Thousands place: Reserved | 0x0000 | <input type="radio"/> |
| P35.36 | Speed-loop differential gain of motor 2 | Setting range: 0.00–10.00s | 0.00 | <input type="radio"/> |

| Function code | Name | Description | Default | Modify |
|---------------|--|--|---------|----------------------------------|
| P35.43 | Motor 2 inertia identification torque | 0.0–100.0% | 10.0 | <input type="radio"/> |
| P35.44 | Enabling motor 2 inertia identification | 0–1 0: Disable 1: Enable | 0 | <input checked="" type="radio"/> |
| P35.45 | Max. flux weakening current of SM 2 | Setting range: 0.0–200.0% Note: 100% corresponds to the motor rated current. | 100.0 | <input checked="" type="radio"/> |
| P35.46 | Vector control optimization parameter of motor 2 | Setting range: 0x0000–0x0FFF Bit 0: Enable voltage feedforward compensation (valid in FVC) Bit 1: Enable axis-d voltage cross decoupling (valid in FVC) Bit 2: Enable axis-q voltage cross decoupling (valid in FVC) Bit 3: Enable closed-loop disturbance feedforward compensation Bit 4: Axis-q voltage restriction selection 0: Restricted to 1.2 times the motor rated voltage 1: Restricted to axis-d voltage Bit 5: Mutual inductance self-adaptation enabling 0: Invalid 1: Enable Bit 6: Direct-axis inductance (Ld) saturation enabling 0: Invalid 1: Enable (suitable for synchronous reluctance motors or synchronous motors where inductance varies significantly with current) Bit 7: Quadrature-axis inductance (Lq) | 0x0037 | <input checked="" type="radio"/> |

| Function code | Name | Description | Default | Modify |
|---------------|--|--|---------|----------------------------------|
| | | saturation enabling 0: Invalid 1: Enable (suitable for synchronous reluctance motors or synchronous motors where inductance varies significantly with current) Bit 8: Torque control current optimization enabling 0: Invalid 1: Enable (suitable for low torque tension control applications) Bit 9: Current loop optimization enabling 0: Invalid 1: Enable (suitable for low carrier frequency ratio applications) Bit 10: Speed loop optimization enabling 0: Invalid 1: Enable (requiring inertia identification) Bit 11–Bit 15: Reserved | | |
| P35.49 | Closed-loop speed observation band width of motor 2 | Setting range: 1.0–200.0 | 10.0 | <input type="radio"/> |
| P35.50 | Vector control energy-saving mode selection of motor 2 | Setting range: 0–3 0: Invalid 1: Max. efficiency (recommended) 2: Optimal power factor 3: MTPA | 0 | <input checked="" type="radio"/> |
| P35.51 | Energy-saving optimization coefficient of motor 2 | Setting range: 25.0%–400.0% | 100.0 | <input type="radio"/> |
| P35.54 | Current-loop band width of motor 2 | Setting range: 0–2000 Note: • P35.54 is a current loop PI regulation | 400 | <input type="radio"/> |

| Function code | Name | Description | Default | Modify |
|---------------|--|--|---------|----------------------------------|
| | | parameter. It impacts the dynamic response speed and control accuracy of the system. Generally, you do not need to modify it. <ul style="list-style-type: none"> Applicable to SVC 0 (P00.00=0) and SVC 1 (P00.00=1). | | |
| P35.58 | Quick exciting current of motor 2 | 0.0–200.0% | 0.0 | <input checked="" type="radio"/> |
| P35.65 | Current-loop integral coefficient after autotuning of motor 2 | Setting range: 0–65535 | 0 | <input type="radio"/> |
| P35.68 | Upper limit frequency bias value in torque control of motor 2 | Setting range: 0.00Hz–P00.03 | 0.00 | <input type="radio"/> |
| P35.69 | Upper limit frequency ACC/DEC selection in torque control of motor 2 | Setting range: 0–4 0: No limit on acceleration or deceleration 1: ACC/DEC time 1 2: ACC/DEC time 2 3: ACC/DEC time 3 4: ACC/DEC time 4 | 0 | <input type="radio"/> |

Group P36—V/F control of motor 2

| Function code | Name | Description | Default | Modify |
|---------------|------------------------------|---|---------|----------------------------------|
| P36.00 | V/F curve setting of motor 2 | Specifies the V/F curve of motor 1 to meet the needs of different loads. Setting range: 0–5 0: Straight-line V/F curve, applicable to | 0 | <input checked="" type="radio"/> |

| Function code | Name | Description | Default | Modify |
|---------------|----------------------------------|--|---------|-----------------------|
| | | <p>constant torque loads</p> <p>1: Multi-point V/F curve</p> <p>2: Torque-down V/F curve (power of 1.3)</p> <p>3: Torque-down V/F curve (power of 1.7)</p> <p>4: Torque-down V/F curve (power of 2.0)</p> <p>Curves 2 – 4 are applicable to the torque loads such as fans and water pumps. You can adjust according to the characteristics of the loads to achieve best performance.</p> <p>5: Customized V/F (V/F separation); in this mode, V can be separated from F and F can be adjusted through the frequency setting channel set by P00.06 or the voltage setting channel set by P36.13 to change the characteristics of the curve.</p> | | |
| P36.01 | Torque boost of motor 2 | <p>Setting range: 0.0–10.0%</p> <p>⚡Note: 100% corresponds to the rated voltage of motor 1. When the value is set to 0.0%, the VFD uses automatic torque boost.</p> | 0.0 | <input type="radio"/> |
| P36.02 | Torque boost cut-off of motor 2 | <p>Setting range: 0.0–50.0%</p> <p>⚡Note: 100% corresponds to the rated frequency of motor 1.</p> | 20.0 | <input type="radio"/> |
| P36.03 | V/F frequency point 1 of motor 2 | <p>When P36.00=1 (multi-dot V/F curve), you can set the V/F curve through P36.03–P36.08.</p> <p>Setting range: 0.00–P36.05(Hz)</p> <p>⚡Note: $V1 \leq V2 \leq V3$, $f1 \leq f2 \leq f3$ Too high voltage for low frequency will cause motor overheat or damage and cause VFD overcurrent stall or overcurrent protection.</p> | 0.00 | <input type="radio"/> |
| P36.04 | V/F voltage point 1 of motor 2 | <p>Setting range: 0.0–110.0%</p> <p>⚡Note: See the description for P36.03. 100% corresponds to the rated voltage of motor 1.</p> | 0.0 | <input type="radio"/> |
| P36.05 | V/F frequency point 2 of motor 2 | <p>Setting range: P36.03–P36.07 (Hz)</p> <p>⚡Note: See the description for P36.03.</p> | 0.00 | <input type="radio"/> |

| Function code | Name | Description | Default | Modify |
|---------------|--|--|---------|-----------------------|
| P36.06 | V/F voltage point 2 of motor 2 | Setting range: 0.0–110.0% ⚡ Note: See the description for P36.03. 100% corresponds to the rated voltage of motor 1. | 0.0 | <input type="radio"/> |
| P36.07 | V/F frequency point 3 of motor 2 | Setting range: P36.05–P34.02 (Hz, Rated frequency of AM 2) or P36.05–P34.16 (Hz, Rated frequency of SM 2) ⚡ Note: See the description for P36.03. | 0.00 | <input type="radio"/> |
| P36.08 | V/F voltage point 3 of motor 2 | Setting range: 0.0–110.0% ⚡ Note: See the description for P36.03. 100% corresponds to the rated voltage of motor 1. | 0.0 | <input type="radio"/> |
| P36.09 | V/F slip compensation gain of motor 2 | Used to compensate for the motor rotating speed change caused by load change in the space voltage vector mode, and thus improve the rigidity of the mechanical characteristics of the motor. Setting range: 0.0–200.0% | 100.0 | <input type="radio"/> |
| P36.10 | Low-frequency oscillation control factor of motor 2 | In space voltage vector control mode, the motor, especially the large-power motor, may experience current oscillation at certain frequencies, which may cause unstable motor running, or even VFD overcurrent. You can adjust the two function parameters properly to eliminate such phenomenon. Setting range: 0–100 | 10 | <input type="radio"/> |
| P36.11 | High-frequency oscillation control factor of motor 2 | | 10 | <input type="radio"/> |
| P36.12 | Oscillation control threshold of motor 2 | Setting range: 0.00Hz–P00.03 | 30.00 | <input type="radio"/> |
| P36.13 | Voltage setting channel selection for motor 2 | Setting range: 0–7 0: Set by P36.14 1: AI1 2: AI2 3: AI3 | 0 | <input type="radio"/> |

| Function code | Name | Description | Default | Modify |
|---------------|--|---|---------|----------------------------------|
| | | 4: Reserved 5: High-speed pulse HDI1 6-7: Reserved 8: Multi-step speed running 9: PID control 10: Modbus/Modbus TCP communication 11: Reserved 12: Ethernet communication 13: Reserved 14: EtherCAT/PROFINET/EtherNet IP communication 15: Reserved | | |
| P36.14 | Voltage set through keypad for motor 2 | The function code is the voltage digital setting when "keypad" is selected as the voltage setting channel. Setting range: 0.0-100.0% | 100.0 | <input type="radio"/> |
| P36.15 | Voltage increase time of motor 2 | Voltage increase time means the time needed for the VFD to accelerate from min. output voltage to the max. output frequency. Setting range: 0.0-3600.0s | 5.0 | <input type="radio"/> |
| P36.16 | Voltage decrease time of motor 2 | Voltage decrease time means the time needed for the VFD to decelerate from the max. output frequency to min. output voltage. Setting range: 0.0-3600.0s | 5.0 | <input type="radio"/> |
| P36.17 | Max. output voltage of motor 2 | Specifies the upper limit of output voltage. Setting range: P36.18-100.0% ⚡Note: 100% corresponds to the motor rated voltage. | 100.0 | <input checked="" type="radio"/> |
| P36.18 | Min. output voltage of motor 2 | Specifies the lower limit of output voltage. Setting range: 0.0%-P36.17 ⚡Note: 100% corresponds to the motor rated voltage. | 0.0 | <input checked="" type="radio"/> |
| P36.19 | Weakening coefficient in constant power zone for motor 2 | Setting range: 1.00-1.30 | 1.00 | <input type="radio"/> |

| Function code | Name | Description | Default | Modify |
|---------------|---|---|---------|-----------------------|
| P36.20 | Pull-in current 1 in V/F control for SM 2 | When the SM VF control mode is enabled, the function code is used to set the reactive current of the motor when the output frequency is lower than the frequency specified by P36.22. Setting range: -100.0%–100.0% Note: 100% corresponds to the motor rated current. | 30.0 | <input type="radio"/> |
| P36.21 | Pull-in current 2 in V/F control for SM 2 | When the SM VF control mode is enabled, the function code is used to set the reactive current of the motor when the output frequency is greater than the frequency specified by P36.22. Setting range: -100.0%–100.0% Note: 100% corresponds to the motor rated current. | 10.0 | <input type="radio"/> |
| P36.22 | V/F control pull-in current frequency switching point for SM 2 | When the SM VF control mode is enabled, the function code is used to set the frequency threshold for the switching between pull-in current 1 and pull-in current 2. Setting range: 0.0–200.0% Note: 100% corresponds to the motor rated frequency. | 20.0 | <input type="radio"/> |
| P36.23 | Reactive current closed-loop proportional coefficient in V/F control for SM 2 | When the SM VF control mode is enabled, the function code is used to set the proportional coefficient of reactive current closed-loop control. Setting range: 0–500 | 50 | <input type="radio"/> |
| P36.24 | V/F control reactive current closed-loop integral time for SM 2 | When the SM VF control mode is enabled, the function code is used to set the integral coefficient of reactive current closed-loop control. Setting range: 0–300 | 30 | <input type="radio"/> |

| Function code | Name | Description | Default | Modify |
|---------------|---|--|---------|----------------------------------|
| P36.25 | V/F control reactive closed-loop output limit for SM 2 | Setting range: 0–16000 | 8000 | <input type="radio"/> |
| P36.26 | Enabling IF mode for AM 2 | Setting range: 0–1 | 0 | <input type="radio"/> |
| P36.27 | Current setting in IF mode for AM 2 | Setting range: 0.0–200.0% | 120.0 | <input type="radio"/> |
| P36.28 | Proportional coefficient in IF mode for AM 2 | Setting range: 0–5000 | 350 | <input type="radio"/> |
| P36.29 | Integral coefficient in IF mode for AM 2 | Setting range: 0–5000 | 150 | <input type="radio"/> |
| P36.30 | Frequency threshold for switching off IF mode for motor 2 | Setting range: 0.00Hz–P36.31 | 10.00 | <input type="radio"/> |
| P36.31 | End frequency point for switching off IF mode for motor 2 | Setting range: P36.30–P00.03(Hz) | 25.00 | <input type="radio"/> |
| P36.32 | V/F control energy-saving mode selection for AM 2 | Setting range: 0–3 0: Disable (Energy saving is invalid) 1: Max. efficiency 2: Optimal power factor 3: Max. ratio of torque to current | 0 | <input checked="" type="radio"/> |
| P36.33 | V/F control energy-saving optimization coefficient for AM 2 | Setting range: 25.0%–400.0% | 100.0 | <input type="radio"/> |

Your Trusted Industry Automation Solution Provider



Shenzhen INVT Electric Co., Ltd.

Address: INVT Guangming Technology Building, Songbai Road, Matian,
Guangming District, Shenzhen, China

INVT Power Electronics (Suzhou) Co., Ltd.

Address: No. 1 Kunlun Mountain Road, Science & Technology Town,
Gaixin District, Suzhou, Jiangsu, China

Website: www.invt.com



INVT mobile website



INVT e-manual



6 6 0 0 1 - 0 1 4 5 6