

LGT 015 – LGT 090 Safety Light Grids

- ▶ HIGH AVAILABILITY ◀
- ▶ MINIMUM DIMENSIONS ◀
- ▶ UNIVERSAL APPLICATION ◀

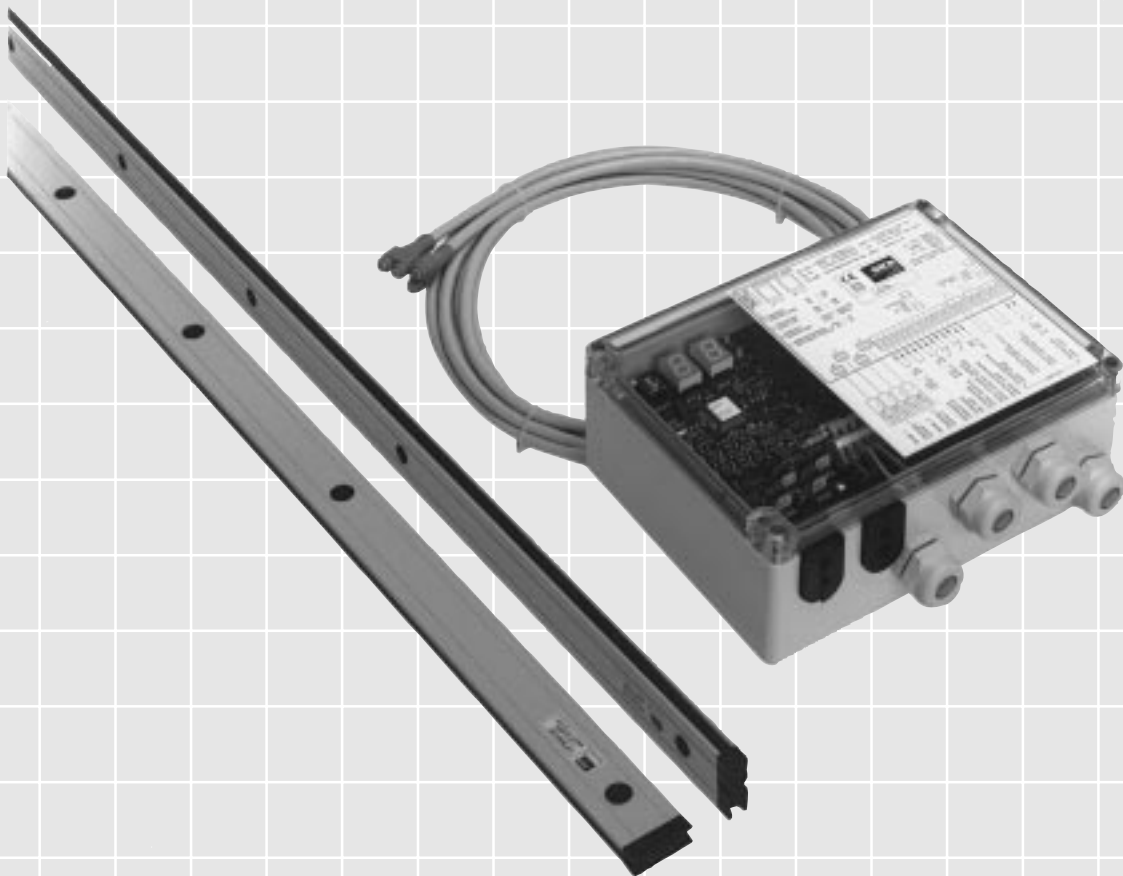

Contents

1	General	3	6	Indicators and diagnostic elements	15
1.1	Features	3	6.1	Indicators on the sender and receiver strips	15
2	Applications and operating conditions	4	6.2	Indicators in control unit	15
2.1	Applications	4	6.3	Seven-segment display in control unit	16
2.2	Operating conditions	5	7	Test instructions	17
2.3	General Notes on Safety Protective Measures	5	7.1	Pre-commissioning tests	17
3	System structure	6	7.2	Regular checking of the safety device by qualified personnel	17
4	Functions	6	7.3	Daily checking of the safety device by authorised and instructed personnel	17
5	Installation and commissioning	7	8	Technical data	18
5.1	General	7	9	Dimensions	19
5.1.1	Safety distance from hazardous point	7	10	Connection diagram	21
5.1.2	Distance from reflective surfaces	8	11	LGT Safety Light Grid Selection	22
5.1.3	Multiple safeguarding	8	11.1	LGT selection table	22
5.2	Mechanical mounting	9	11.2	Control unit and Connection lead Selection Table	23
5.3	Electrical installation	9	11.3	Accessories Selection Table	23
5.3.1	Connection between control unit and customer interface	9	12	Check list	24
5.3.2	Switching outputs	10	13	Conformity	25
5.3.3	Operating modes	11			
5.3.4	Machine control	11			
5.3.5	Test input	12			
5.3.6	Contactormonitor	12			
5.3.7	Sender power setting	13			
5.3.8	Blanking	13			
5.3.9	Behaviour of the switching outputs in various operating modes	14			

Approvals

EU Europe

TÜV Rheinland
Am Grauen Stein
51105 Köln



The generally recognised rules of engineering are carefully applied when developing and manufacturing SICK equipment. Naturally, all products comply with the ISO 9000 quality standard.

1 General

LGT Safety Light Screens are non contact protective devices with a resolution of 30 mm. They belong to safety category 2 and as such are testable protective devices. The units are designed for operation in industrial environments and are characterised by the following features:

- ▶ High availability
- ▶ Minimum dimensions (10 x 30 mm²)
- ▶ Stable construction
- ▶ Universal application
- ▶ Easy to install

The following characteristic data are applicable in practice (Fig. 1).

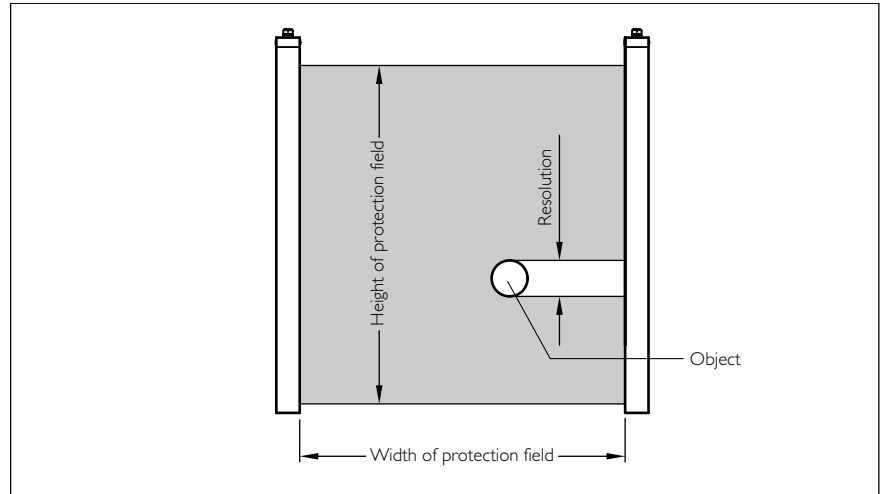

Fig. 1. Characteristic data of an LGT safety light grid

Maximum width of protective field	6 m
Resolution (obstacle detection)	30 mm
Maximum height of protective field	905 mm
Minimum height of protective field	155 mm

1.1 Features

The main features of the LGT safety light screen are:

- ▶ Relay outputs
- ▶ Up-to-date microprocessor technology and specially designed ICs (ASIC)
- ▶ Easy to mount and adjust
- ▶ Modular connection system
- ▶ Only three components (control unit, sender and receiver strips)
- ▶ Two sensor pairs can be connected to one control unit
- ▶ Double protective field height by cascading
- ▶ Large signal reserve
- ▶ EC approval

2 Applications and conditions of operation

2 Applications and conditions of operation

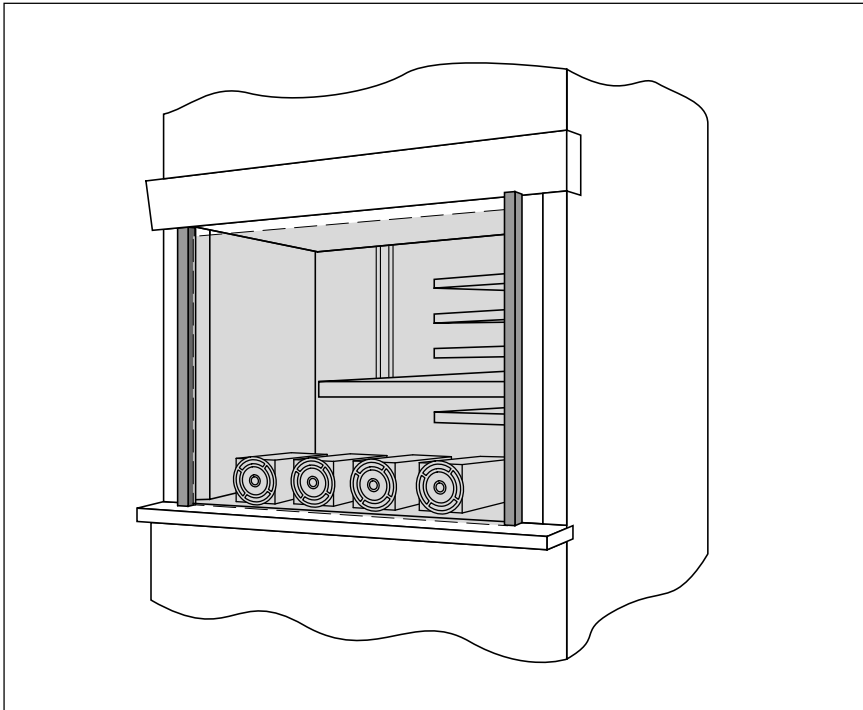

Fig. 2. Point-of-operation guarding with an LGT Safety Light Grid

2.1 Applications

LGT Safety Light Grids are used for point-of-point guarding (Fig. 2 and 3) and hazardous area guarding.

Typical applications include:

- ▶ Form clamps as used in the wood industry
- ▶ Packaging machines
- ▶ Processing centres
- ▶ Production lines
- ▶ Revolving transfer machines
- ▶ Component insertion machines
- ▶ Continuous lifts
- ▶ Palletizers etc.

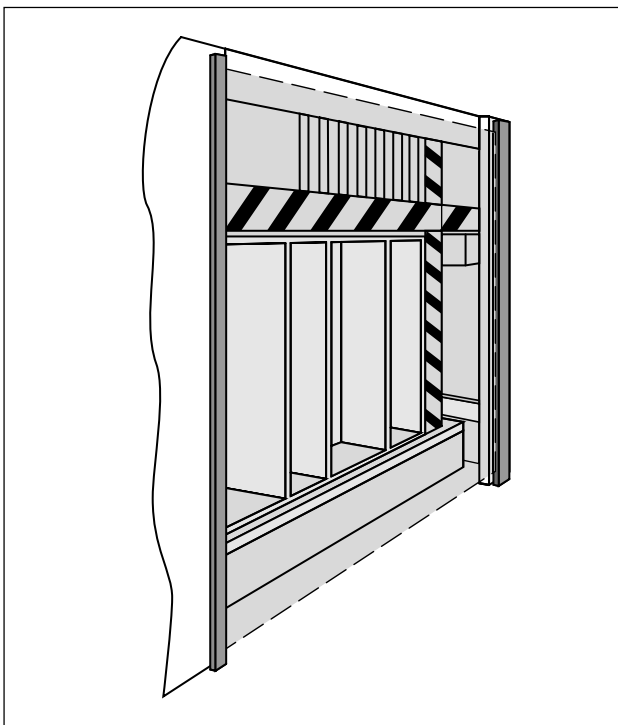

Fig. 3. Point-of-point guarding with an LGT Safety Light Grid

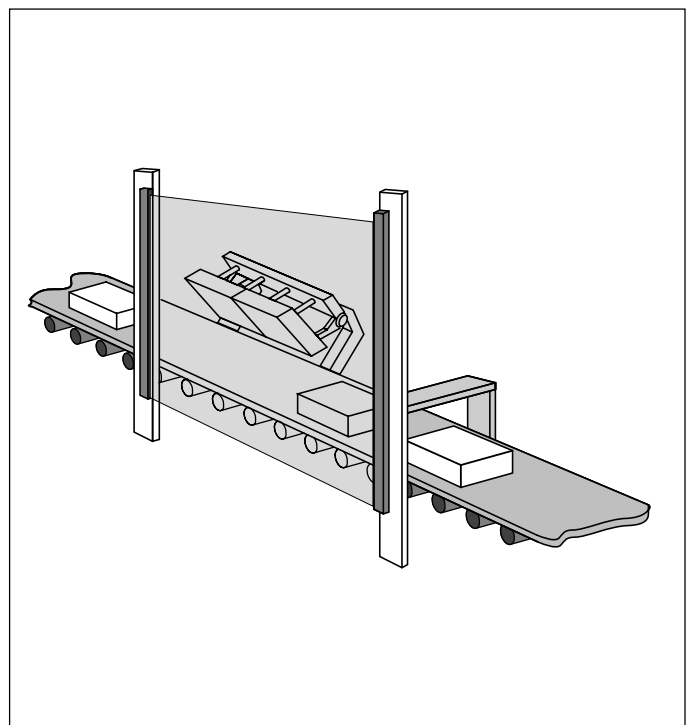

Fig. 4. Point-of-point guarding with an LGT Safety Light Grid

2.2 Conditions of Application

The machine or system must be electrically controlled and it must be possible to interrupt operation at any time. When installing the LGT, ensure that access above, below or behind the protective zone is not possible.

Operation and installation of protective devices are subject to the relevant legal and official regulations. These regulations vary according to the application of the light grid system.

2.3 General Notes on Safety Protective Measures

1. The national/international regulations apply for the use/installation of non-contact protectiveon equipment as well as for commissioning and regular recurring technical checks, in particular
 - ▶ Machine directive 98/37 EC
 - ▶ Guidelines for working substances 89/655 EEC
 - ▶ Machinery Safety regulations as well as
 - ▶ Locally Enforced Regulations for the prevention of accidents/rules for safety.

It is the responsibility of the manufacturers and users of the machine on which our protectiveon equipment is used, to discuss all safety rules and regulations which regulations, which may apply with the responsible authorities and to observe these rules and regulations.

2. Furthermore, our notes, in particular the test regulations (see chapter entitled Tests) in this Technical Description or these Operating Instructions (such as use, assembly, installation or integration into the machine control unit) must be observed and followed.
3. The tests shall be carried out by experts and/or persons specifically authorized or commissioned to perform these tests. They shall be documented at all times in a clear and concise comprehensible way.
4. Our Operating Instructions shall be given to the employee (operator) working at the machine on which our protectiveon equipment is used. The employee shall be introduced to his job and the equipment by an expert.
5. This leaflet is enclosed as an appendix and serves as a checklist for checks carried out by the manufacturer and fitter.

3 System structure

3 System structure

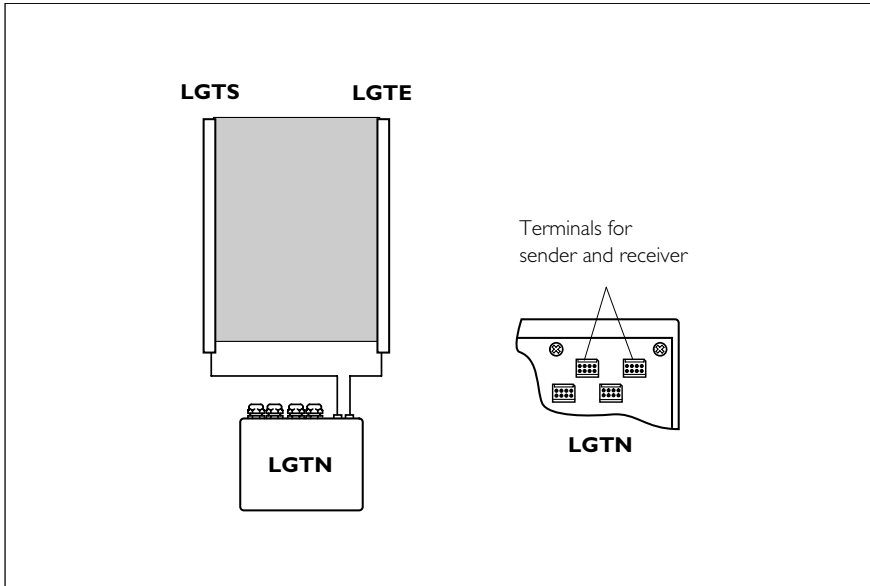

Fig. 5. LGT Safety Light Grid comprising a control unit LGTN, sender LGTS, receiver LGTE and the two connecting leads to the control unit

The LGT Safety Light Grid comprises

- ▶ Control unit LGTN
- ▶ Sender LGTS and
- ▶ Receiver LGTE

as well as the two connecting leads to the control unit (Fig. 5).

Two sender and receiver units can be connected to a LGTN control unit.

If two sender units and two receiver units are operated in parallel the protective field height can be doubled (Fig. 6).

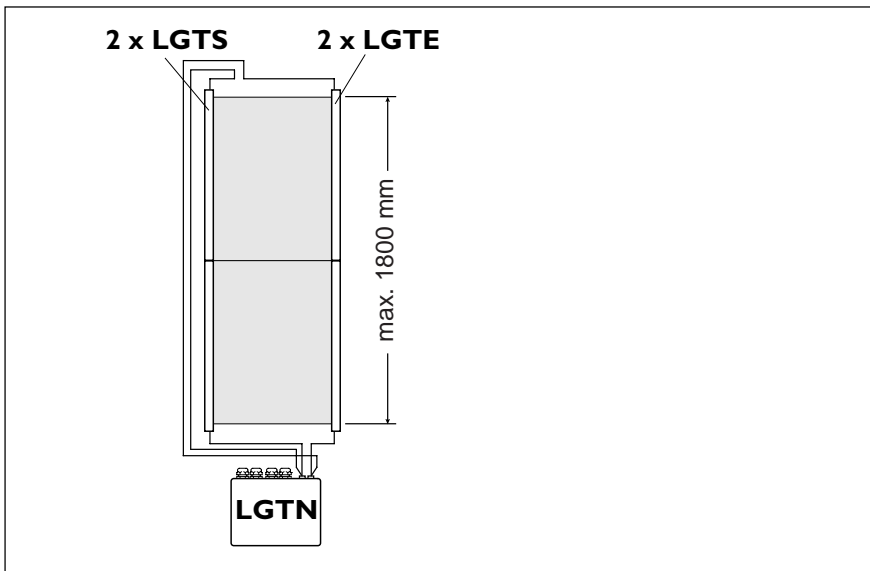

Fig. 6. Two LGT safety light grid on a LGTN control unit: Double protective field height.

4 Functions

The height of the protective field depends on the size of the system used.

The sender and receiver units of the LGT contain a series of individual elements which together form a light grid of parallel beams.

If only one light beam is interrupted, a switching command is triggered which stops the machine.

5 Installation and Commissioning

The LGT must be commissioned in accordance with the following steps

- 1 Clarify and carry out mechanical mounting
- 2 Connect the sender and receiver strips to the control unit
- 3 Set the DIP switches "With ..." or "Without restart interlock" (preset at factory), fig. 15
- 4 Connect the "machine control" input (jumper or terminal)
- 5 Set the DIP switch: either 1 or 2 LGT connected to control unit (fig. 15)
- 6 Connect or jumper the contactor monitor
- 7 Perform blanking in accordance with Section 5.3.8 if required
- 8 Set the sender power in accordance with 5.3.7
- 9 Insert the output elements in the switch-off control line of the machine

The individual measures for this purpose are described in the following chapters.

5.1 General

The LGT can be operated in any position as long as the specified safety distances and sufficient protective height are provided (see 11 selection table).

Before the unit is installed, check the components to ensure that they are complete:

The LGT Light Grid comprises 5 individual parts. These must always be available before starting the installation:

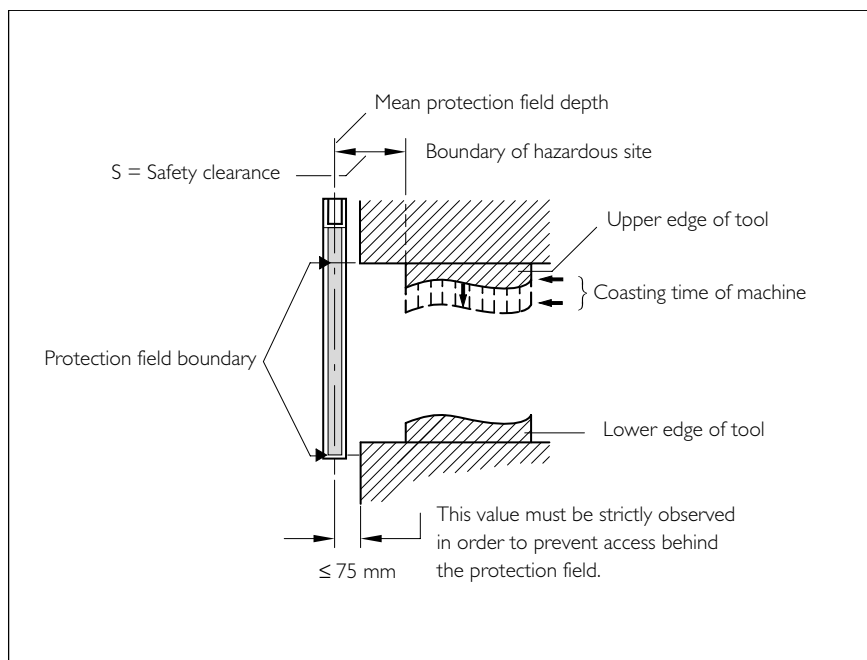

Fig. 7. Determining the coasting time and the safety clearance

- 1 control unit LGTN
- 1 sender strip LGTS
- 1 receiver strip LGTE
- 2 connecting leads (preassembled)
- Test rod (30 mm) as accessory available.

Two sensor pairs (sender and receiver) can be connected to each control unit.

5.1.1 Safety Distance from Hazardous Point

The protective device requires a certain minimum distance to the hazardous point to ensure that the point can only be reached once the machine or system has come to a standstill (Fig. 7). The safety distance (as per EN 775, 999 and 294) depends on the

- ▶ stopping time of the machine,
- ▶ response time of the protective device,
- ▶ resolution of the light grid and the reach speed.

The stopping time is a measured value of the machine. The *reach speed* is equal to

at (short distances) up to 500 mm
 safety distance 2 m/s
 greater than this 1.6 m/s

The safety distance S is calculated using the formula:

For $S \leq 500$ mm

$$S = 2000 \cdot T + 8 (d - 14)$$

greater ($S = > 500$ mm)

$$S = 1600 \cdot T + 8 (d - 14)$$

S Safety distance
 T Total response time in s (stopping time of the machine + response time LGT)
 d Resolution

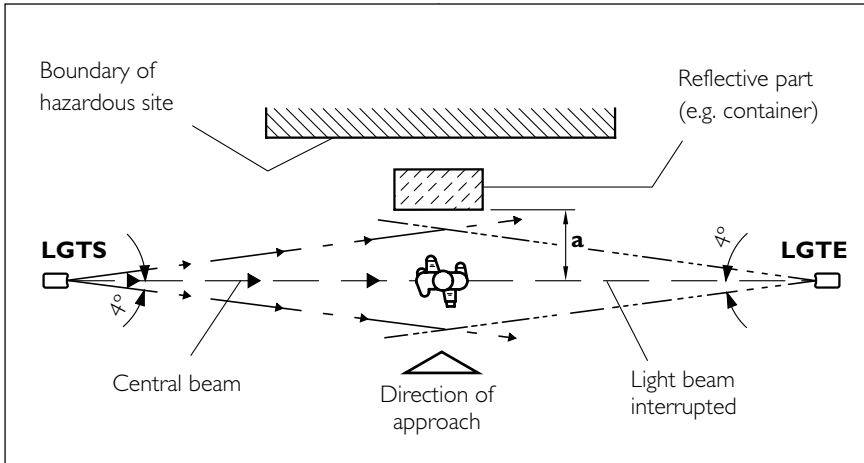

Fig. 8. Correct mounting and alignment. No reflection. The obstacle is clearly detected.

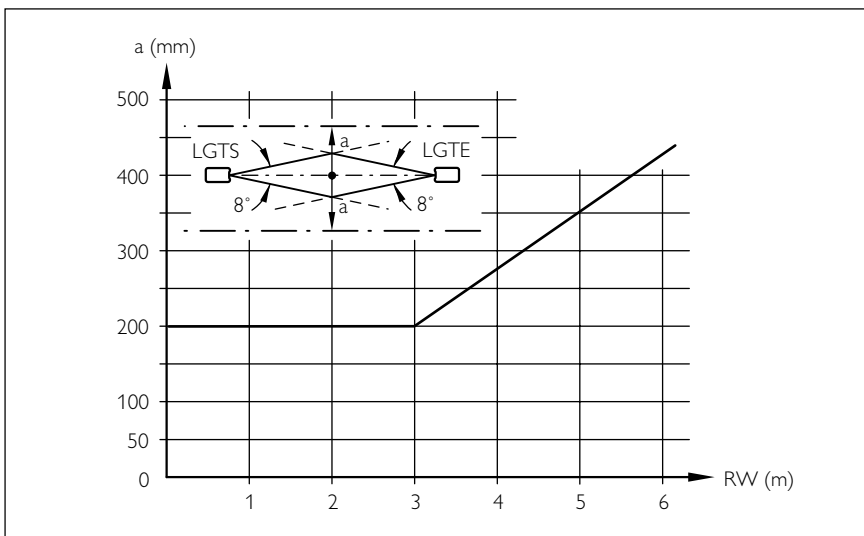

Fig. 9. Distance a as a function of the range RW

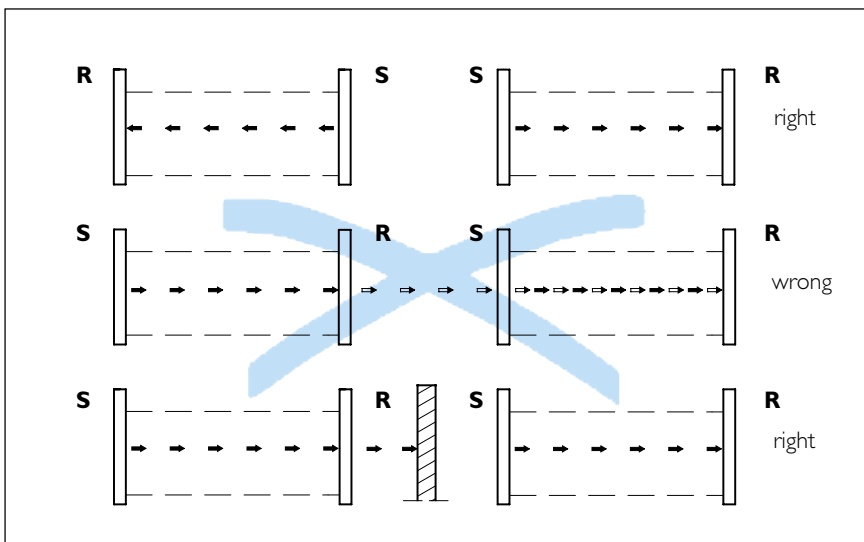

Fig. 10. Mounting two LGT systems in series

5.1.2 Distance to Reflective Surfaces

Reflective surfaces located, placed or mounted within the transmission and reception lobe can deflect the light beams and may prevent an object from being detected (Fig. 8).

For this reason, a minimum distance a between reflective objects and the optical axis (straight-line connection LGTS/E) must be observed. The distance a depends on the respective distance between the sender and receiver and on the alignment of the units (Fig. 9).

5.1.3 Multiple safeguarding

When using two LGT systems (pairs), mutual interference must be avoided between each safeguarded area. Since the light beams diverge, the cross-section of the beams increases proportionately to the distance between the LGTS and LGTE. The light beam must only be received by the corresponding LGTE. In order to prevent mutual interference between LGTs arranged in sequence, the alignment must be taken into account when installing the units (Fig. 10).

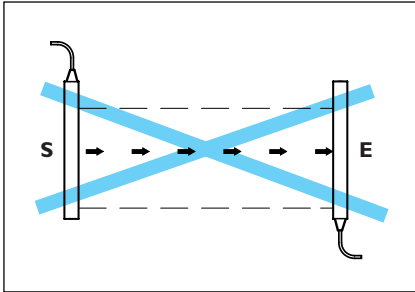

Fig. 11. The sender and receiver units must not be installed rotated at 180° angles to each other.

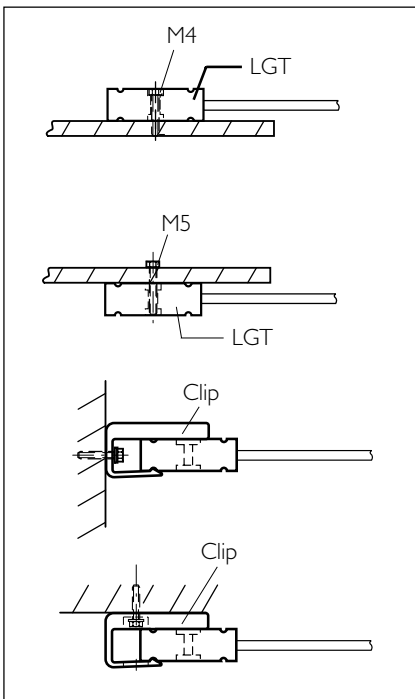

Fig. 12. Fixing options for LGT

5.2 Mechanical mounting

The sender and receiver units must not be installed rotated at 180° angles to each other (Fig. 11).

The sender and receiver strips of the light grid are secured in the light screen by means of the threaded M5 bolts or an M4 screw inserted through the bolt hole or the M5 bolt can be used directly (Fig. 12).

In order to ensure maximum flexibility at the mounting location and to enable light grids to be replaced quickly, snap-on clips have been developed (Fig. 12). These can be directly screwed onto the mounting surface. The light grids are then simply latched into place to prevent the light grid from slipping as a result of vibration, the grid can additionally be secured to the clips by means of a screw.

The control unit is screwed down using the fixing holes provided in the enclosure. When using the control unit without an enclosure, i.e. mounting in a control cubicle, the control unit chassis is clipped directly onto a DIN rail.

To improve EMC, insulated mounting on the power-driven machinery is recommended. This can be provided by insulating (collared) washers, for example.

5.3 Electrical installation

The preassembled connecting leads must be used to connect the control unit to the sender and receiver strips. Insert the connectors into the terminals provided on the control unit. (Fig. 13)

5.3.1 Connection between the control unit and customer interface

Depending on the type of control unit, a supply voltage of 24 VDC or 115/230 VAC must be provided and the unit connected in accordance with the connection diagram (Appendix 10).

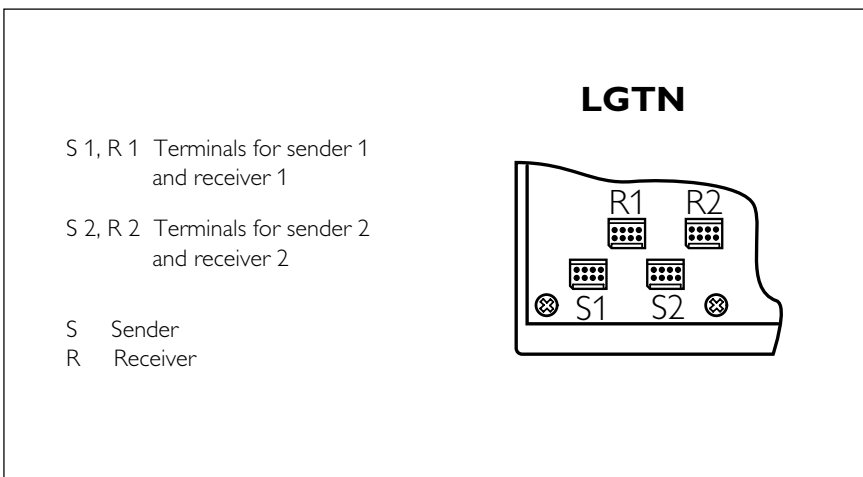

Fig. 13. Terminals for connecting sensor strips to the control unit

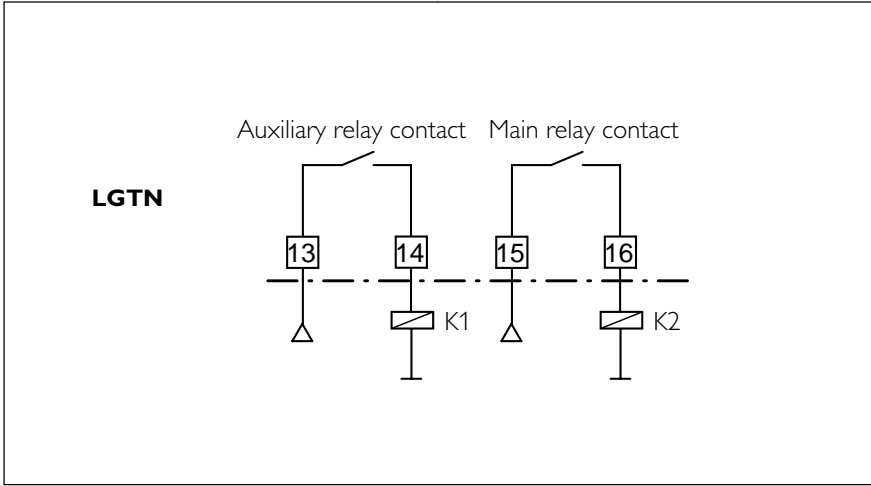

Fig. 14. Output circuit elements

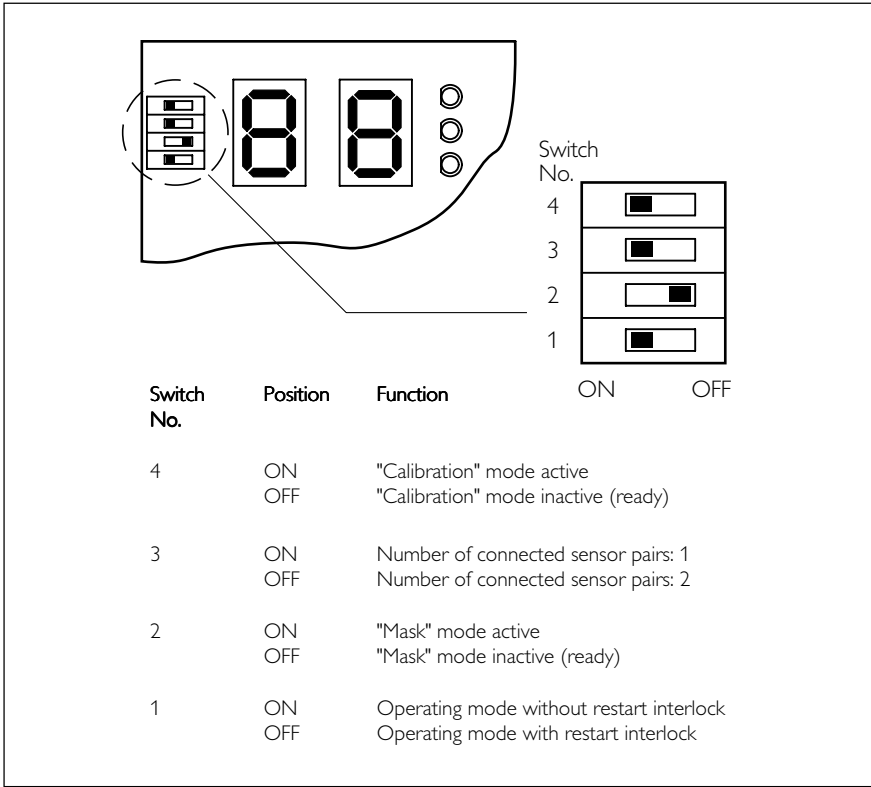

Fig. 15. Operating mode settings on the control unit

On variants with external mode switches:
 Observe the seven-segment display during switches.
 Furthermore, **floating blanking** – although possible (at least in Germany) – is **not permitted**. May be subject to national standards and/or risk assessment.
 Before carrying out blanking again always **check the functioning of all beams** (without blanking). After setting the blanking check that only the desired beams are in fact blanked out.

5.3.2 Switching outputs

The control unit has four switching outputs, each of which performs different functions.

- ▶ Main relay contact output (Fig. 14),
- ▶ Auxiliary relay contact output (Fig. 14),
- ▶ Protective Zone status (PNP),
- ▶ Contamination output (PNP)

The main relay with positively actuated contacts is the "safety" switching output of the LGT. The positively actuated contacts are monitored by the control unit to ensure that they are functioning correctly.

The auxiliary relay with its switching output operates as a second, independent switch-off path should the main relay or controller fail.

We recommend fitting arc suppressors to the contactors at the outputs. This will extend the lives of the relays in the LGTN and suppress interference from external sources.

The output circuits must be provided with adequate protection (e.g. with fuses) in accordance with draft standard EN 50 100.

Fig. 15 shows the funktion of the switches for setting the operating mode of the LGTN

The status of the main and auxiliary relays depends on the status of the protective zone, the operating mode "With restart interlock" or "Without restart interlock" and the command and test inputs.

A semiconductor output provides the exact status of the protective zone (Fig. 16). This output has no safety relevance.

Prot. zone free: output live

Protective zone interrupted: no output

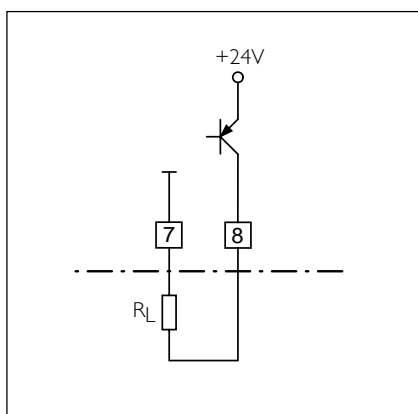

Fig. 16. The semiconductor output gives the actual status of the protective zone

The light grid is monitored continuously for contamination. The status is signalled by means of the contamination semiconductor output (Fig. 17).

Light grid not contaminated: no output

Light grid contaminated: output live

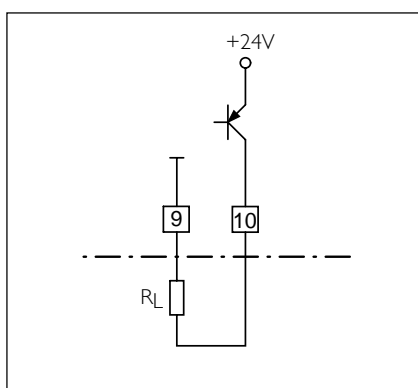

Fig. 17. Contamination semiconductor output

5.3.3 Operating modes

The LGT Light Grid can be operated "with..." or "without restart interlock". This means:

With restart interlock

After the protective zone has been interrupted or a test performed, the contact of the main and auxiliary relays do not close until the machine control has been actuated. This means that the machine cannot resume operation until the protective zone is clear again and the machine control has been actuated. If the duration of the test signal is less than 100 ms, it is not necessary to actuate the machine control. The machine control must also be actuated after the supply voltage has been applied in this operating mode.

Without restart interlock

After the protective zone has been interrupted or a test performed, the contact of the main and auxiliary relays close immediately after the protective zone has been cleared. It is not necessary to actuate the machine control. Operating modes are set via the DIP switches on the control unit board.

In the operating mode "without restart interlock", the contact inputs for the machine control must be bridged.

5.3.4 Machine control

The control switch is used to close the main relay and test relay contact again in operating mode "with restart interlock" when the protective zone is clear again after an interruption or after a test has been successfully performed (Fig. 18). The machine can then resume operation.

A make contact must be connected to the input terminal strip.

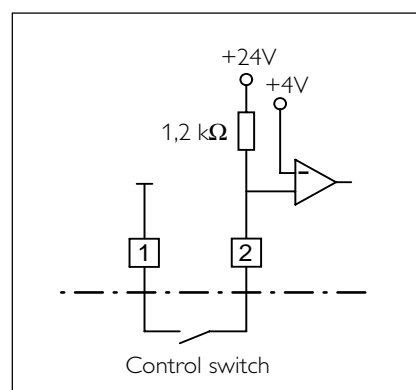

Fig. 18. The machine control is implemented as a make contact

5.3.5 Test input

The test input is used to initiate a test cycle (Fig. 19). In doing so, the LGT including the main relay and response time are monitored to ensure that they are functioning correctly. If a safety-relevant error is detected during the test, the switching outputs remain open. The machine, therefore, cannot resume operation. A break contact must be connected to the test input.

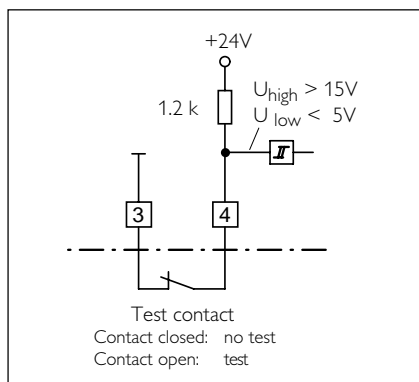

Fig. 19. Test input circuit

Note

Safety can only be guaranteed if the test input is used (installed in the machine controller).

5.3.6 Contactor monitor

The external contactor monitor monitors the contacts of connected contactors to ensure that they do not stick (weld). These must be connected to the LGT as shown in the connection diagram (Fig. 20). The contactor monitor monitors the *static* rest position of the external contactors. If a *dynamic* contactor monitor is specified, the monitor must be integrated into the higher-order controller.

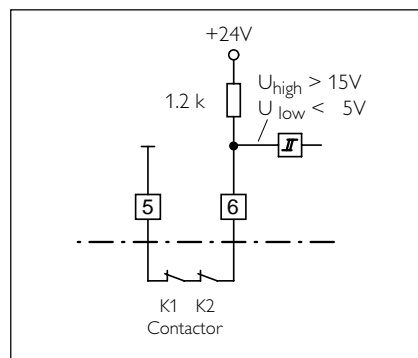

Fig. 20. Contactor monitor circuit

Note

If the protective field is broken very briefly, a lockout together with the error message 14 may occur in the case of heavily rebounding contacts (Table, below). The "Action" column gives the required measures.

If the contact monitoring is provided by externally connected devices, terminals 5 and 6 must be bridged.

Operating mode

„Without restart inhibit“

Action

Break the protective field again
Switch the voltage on and off

Indicators

LGTN lights up green
LGTN lights up green

„With restart inhibit“

Press the control switch

LGTN lights up green

5.3.7 Sender power setting

The LGT has a sender power setting option to enable the sender power to be optimally matched to the ambient conditions and to match the control unit to the light grid types (more than one pair in use). This ensures that the aperture angle always remains below the required value of $\pm 4^\circ$ thus preventing unnecessary load on components.

The sender power is set as follows:

- 1 Mount the LGT in its final position
- 2 Select "Calibration" mode: set DIP switches (Fig. 15) set to control unit print.
- 3 Switch on the power supply

A digit, which depends on whether one or two light grids are connected to the control unit, then appears on the seven-segment displays:

Left-hand display for screen 1
Right-hand display for screen 2

- 4 Adjusting the LGT strips for **maximum** value on the seven-segment display, e.g. "8"; range-dependent (e.g. range 6 m – display ≥ 2).
- 5 Deactivate "Calibration" mode: DIP switches.

Caution:

There must be no intrusion into the protective field during the shutdown operation.

The sender power setting is thus stored.

Once the sender power has been set, the LGT is set for optimum operation at the required installation position.

Important:

The sender power must always be reset before the unit is commissioned and each time the sender and receiver strips are replaced.

5.3.8 Blanking

If mechanical brackets for guiding material are located in the protective zone, this area must be blanked out. For this purpose, up to 4 beams on the LGT can be blanked out, i.e. they no longer have an effect.

Attention:

Since gaps in the protective field are produced as a result of blanking, these gaps must be guarded by other (e.g. mechanical) safety devices.

The blanking is set as follows:

- 1 Mount the LGT in its final position
- 2 Switch off the power supply
- 3 Select "blanking" mode: DIP switches (Fig. 15)
- 4 Switch on the power supply

A digit then appears on the two seven-segment displays, depending on whether one or two light screens are connected to the control unit. The digit indicates the number of beams which are blanked. After approx. 20 seconds the seven-segment display switches to a flash mode with "17", and the yellow LED in the control unit lights up. This means that the blanking setting is stored. It is not possible to blank out more than 4 beams.

- 5 Deactivate "blanking" mode: DIP switches.

The blanking setting is thus stored.

- 6 Switch off the power supply and switch it on again or unplug the reset jumper and re-insert it.

- 7 Make sender powering as described under 5.3.7.

After the blanking setting has been completed, the protective zone must be checked with a test rod (30 mm \varnothing).

The blanking setting also remains stored in the event of a power failure.

An existing blanking setting is displayed continuously as per Fig. 21, bottom.

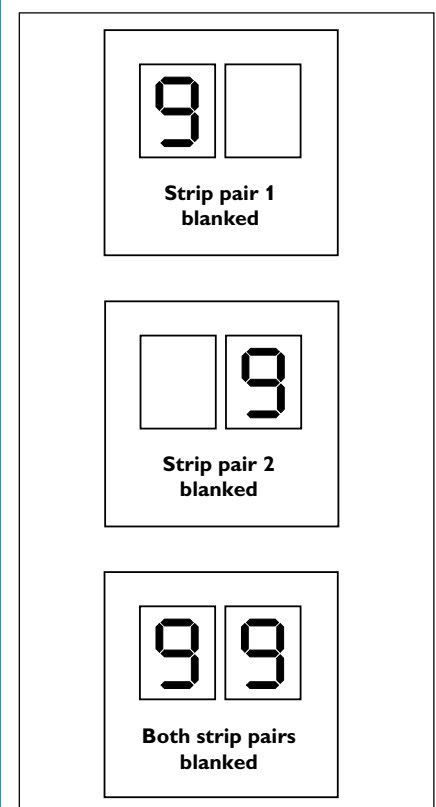

Fig. 21. Blanking shown in display

5.3.9 Behaviour of the switching outputs in the various operating modes

The switching outputs behave as follows in the various operating modes (Fig. 22 to 24).

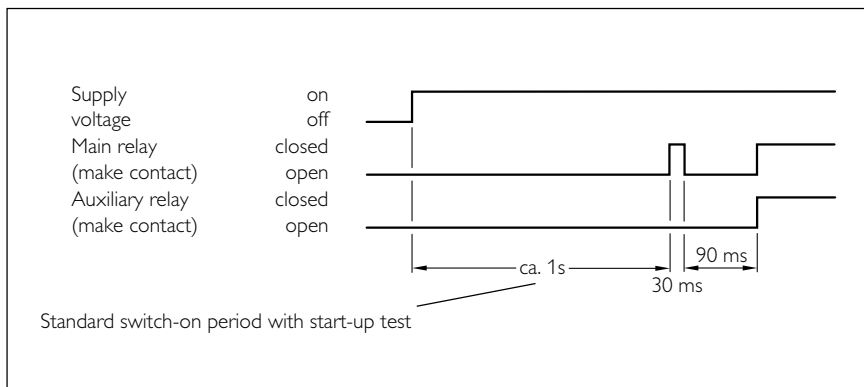

Fig. 22. Behaviour of the switching outputs after application of the supply voltage in operating mode "without restart interlock"

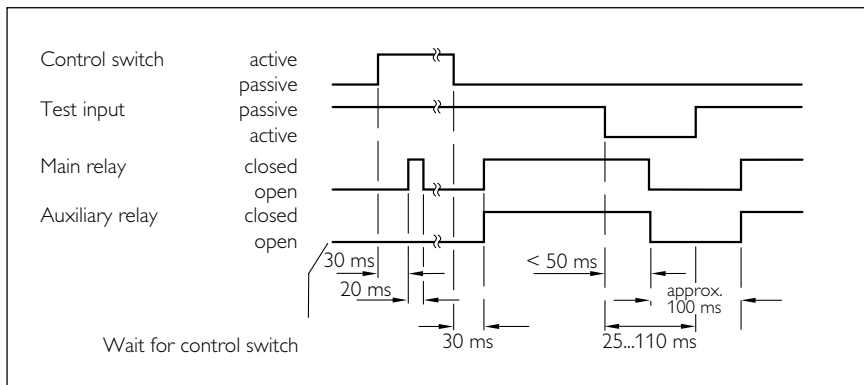

Fig. 23. Behaviour of the switching outputs after machine initiation switch followed by a short test request in the operating mode "with restart interlock".

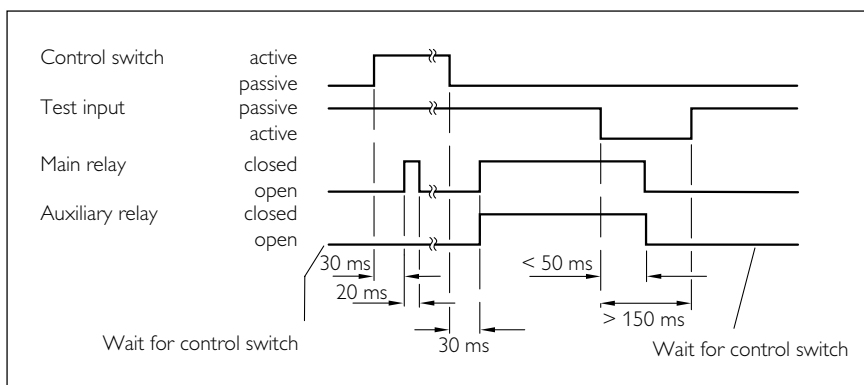

Fig. 24. Behaviour of the switching outputs after machine control initiation followed by long ($\geq 150\text{ ms}$) test request in the operating mode "with restart interlock"

6 Indicators and diagnostic elements

6 Indicators and diagnostic elements

6.1 Indicators in the sender and receiver strips

Sender	yellow	Operating indicator, lights up continuously when the supply voltage is applied.
Receiver	yellow	Operating indicator, lights up continuously when the supply voltage is applied.
	green	Lights up continuously when the light path is not obstructed; flashes if reception inadequate (due to contamination or alignment error).
	red	Lights up when protective zone interrupted.

6.2 Indicators in the control unit

In operating mode "without restart interlock"	green	Lights up continuously when light path unobstructed; flashes if reception is inadequate (due to contamination or alignment error).
	red	Lights up when protective zone interrupted.
In operating mode "with restart interlock"	green	Lights up continuously when light path unobstructed and after enable by machine control; flashes if reception is inadequate (due to contamination or alignment error).
	red	Lights up when protective zone interrupted.
	yellow	Lights up when the machine control must be operated.

6.3 Seven-segment display in control unit

The two-digit seven-segment display (Fig. 25) provides information on the status, faults, alignment, number of blanked beams etc.

Error messages are displayed in blinking mode.

The following information is important for fault diagnosis purposes:

After the fault has been rectified, the control unit must be switched off and on again. When the error has been rectified, the control unit must be switched off and then on again or the reset jumper must be disconnected and then reconnected. If contrary fault messages are displayed on the seven-segment display, check the connection system. If the fault still cannot be rectified, submit the unit for repair or contact the SICK representative.

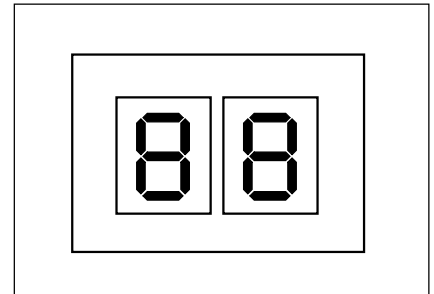

Fig. 25. Seven-segment display

No.	Fault	Corrective measure
10	Restart interlock configuration incorrect (jumper or control unit input)	Check DIP switches and control unit connection
11	DIP switch setting "restart interlock" has changed during operation	Check DIP switch setting
12	DIP switch setting "No. of LGT" does not coincide with the actual number connected	Check DIP switch setting, check plug-in connections of the strips
13	Incorrect sender and receiver configuration	Reset the sender power
14	Contactormonitor not working	Check contactormonitor (see 5.3.6 Contactormonitor)
17	Blanking successfully completed	Blanking procedure completed, reset DIP switches
19	Wait until "Test" button is again released	Release "Test" button
20	Wait until "Machine Control" button is released	Release "Machine Control" button
30	No. of beams on sender and receiver not identical	Check the sender and receiver type assignment. Check connection system.
31	Sender and receiver reversed	Check connections
33	Status signal error from strip 1	Check plug-in connections and type assignment of the strips
37	Excessively high received signal for given range or supply voltage too low	Re-calibrate sender power, check supply voltage
50	No. of beams on sender and receiver not identical	Check the sender and receiver type assignment
53	Status signal error from strip 2	Check plug-in connections and type assignment of the strips
57	Excessively high received signal for given range or supply voltage too low	Re-calibrate sender power, check supply voltage

7 Test instructions

7.1 Pre-commissioning tests

- ▶ The pre-commissioning test serves to confirm compliance with safety requirements specified in the national/international regulations, in particular the Directives governing machinery or equipment use (EC Declaration of Conformity).
- ▶ Test of the efficacy of the safety device on the machine in all machine operating modes.
- ▶ The personnel operating the machine protected by the safety device must be instructed as to its use by qualified personnel of the machine operating company supplier before beginning work. The said instruction is the responsibility of the machine operating company supplier.

7.2 Regular checking of the safety device by qualified personnel

- ▶ Checks based on the applicable national regulations at the intervals specified therein. These checks serve to reveal modifications or manipulation of the safety device since commissioning.
- ▶ The checks must be carried out every time major changes are made to the machine or the safety device, as well as after resetting or repair work in the event of damage to the housing, the front screen, the connecting cables, etc.

7.3 Daily checking of the safety device by authorised and instructed personnel

Run the 30 mm test rod slowly through the protective field at three points:

1. Protective field limits/markings close to the sender (access opening)
2. Protective field limits/markings close to the receiver
3. Protective field limits in the middle between sender and receiver.

In the process only the red LED on the LGTE may light up.

8 Technical Data of LGT Safety Light Grid

8 Technical Data of LGT Safety Light Grid

	min.	typ.	max.
General system data			
Protective field height	150 mm		900 mm
Protective field width	0.1 m		6 m
Resolution		30 mm	
Wave length of the sender		880 nm	
Protection class	1		
Enclosure rating			
Light grid	IP 65		
Control unit	IP 54		
	or IP 20 (for cabinet installation)		
Operating mode	with or without restart inhibit		
Supply voltage U_V ¹⁾			
DC	19.2 V	24 V	28.8 V
ripple ²⁾			5 V _{ss}
or			
AC	92 V	115 V	126.5 V
	184 V	230 V	253 V
frequency	48 Hz		62 Hz
Power consumption			13 W 16 VA
Output			
Main relay			
resistive			4 A, 45 V DC (see diagram)
inductive			4 A, 25 V DC (see diagram)
Auxiliary relay			
resistive			8 A, 55 V DC (see diagram)
inductive			8 A, 15 V DC (see diagram)
Protective zone status	surge-proof		
			100 mA
	$U_V - 2,5$ V (HIGH)		U_V 600 μ A (I_Q)
Dirt indicator	surge-proof		
			100 mA
	$U_V - 2,5$ V (HIGH)		U_V 600 μ A (I_Q)
Response time			50 ms
Length of connecting leads	see 11.2 selection table		³⁾
Operating modes	0.1 mm ²		1.5 mm ²
Operating data			
Safety category	type 2		
Requirements	pr EN 50100		
Operating temperature range	- 10 °C		+ 55 °C
Humidity range	15 %		95 %
Storage temperature range	- 25 °C		+ 70 °C
Dimensions	See 9 Dimensions		
Housing colour	Cadmium yellow, RAL 10-21		
Vibro stability	5 g, 10 ... 55 Hz to IEC 68-2-6		
Shock resistance	10 g, 16 ms acc. IEC 68-2-29		

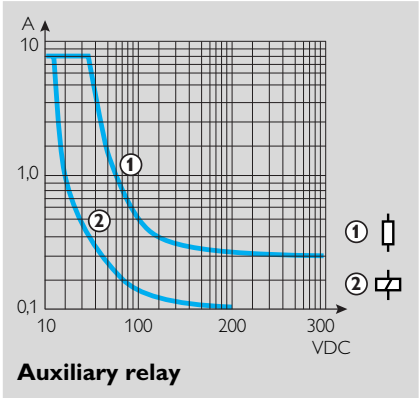
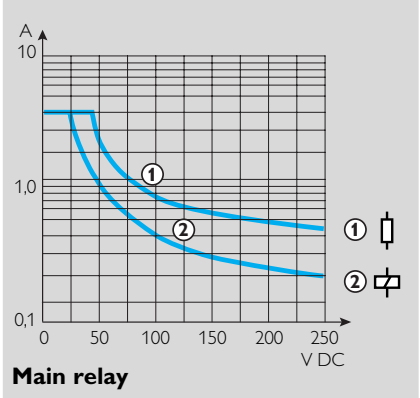

¹⁾ A power supply unit with safeguarded isolation (SEL V, PEL V circuit) must be used.

²⁾ The voltage must not exceed or fall below the limit values.

Caution: In the event of high-energy overvoltages between DC supply and PE potential (≥ 0.5 kV) a switch to AC supply and/or insulated mounting of the sensor strips is recommended. In case of interference also lay the sensor cables isolated from the interfering cable duct.

³⁾ Cannot be shortened.

9 Dimensions

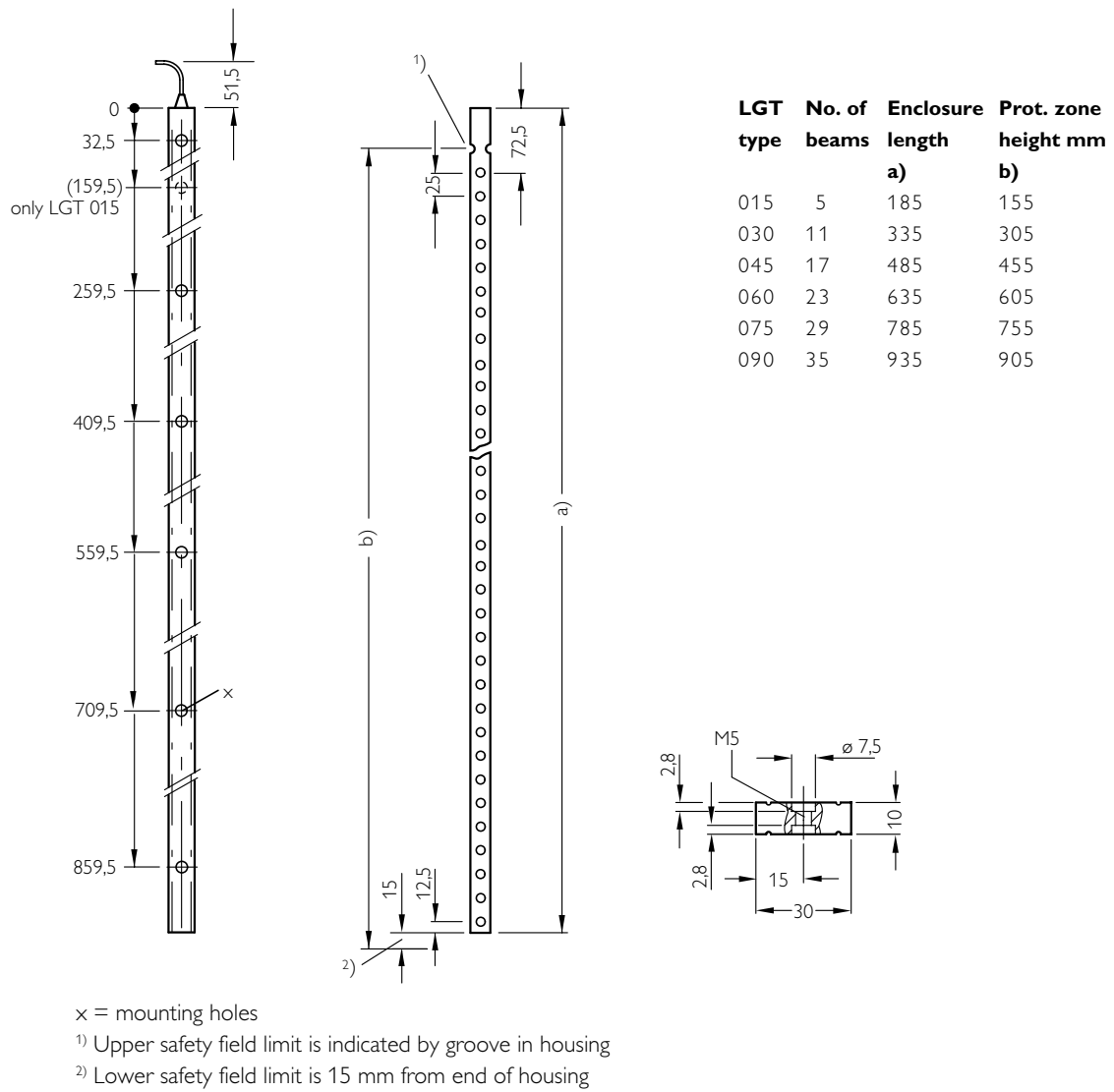
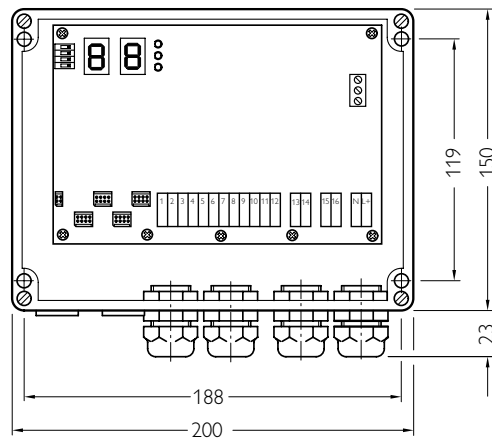
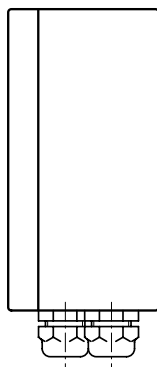
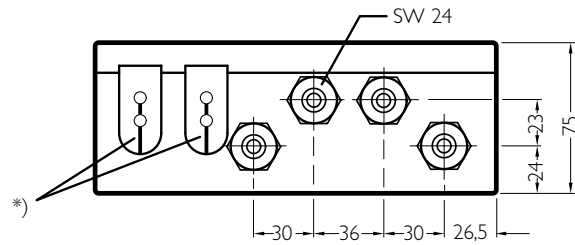

Fig. 26. Dimensions of sender LGTS, receiver LGTE

PG 11
Cable diameter 5 ... 12 mm



*) To receive cables Remove sleeve and prise apart

Fig. 27. Control unit dimensions LGTN

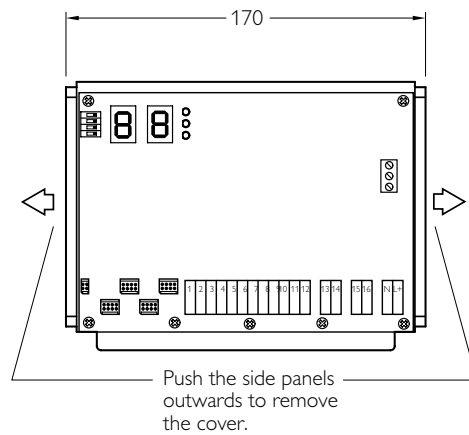
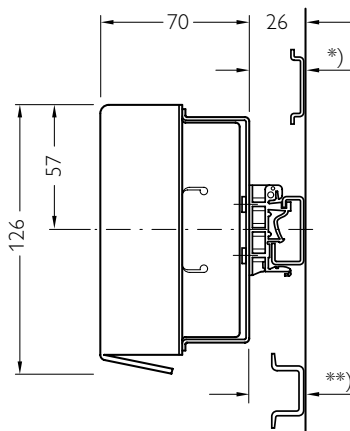

Suitable for installation in a control cabinet.
Suitable for mounting on a support rail to EN 50022 (high or low DIN rail) or EN 50035 (slide rail).

*) for mounting on low DIN rail (20 mm)
**) for mounting on high DIN rail (28 mm)

20 Fig. 28. Dimensional drawing of control unit for installation in a control cabinet

10 Connection diagram

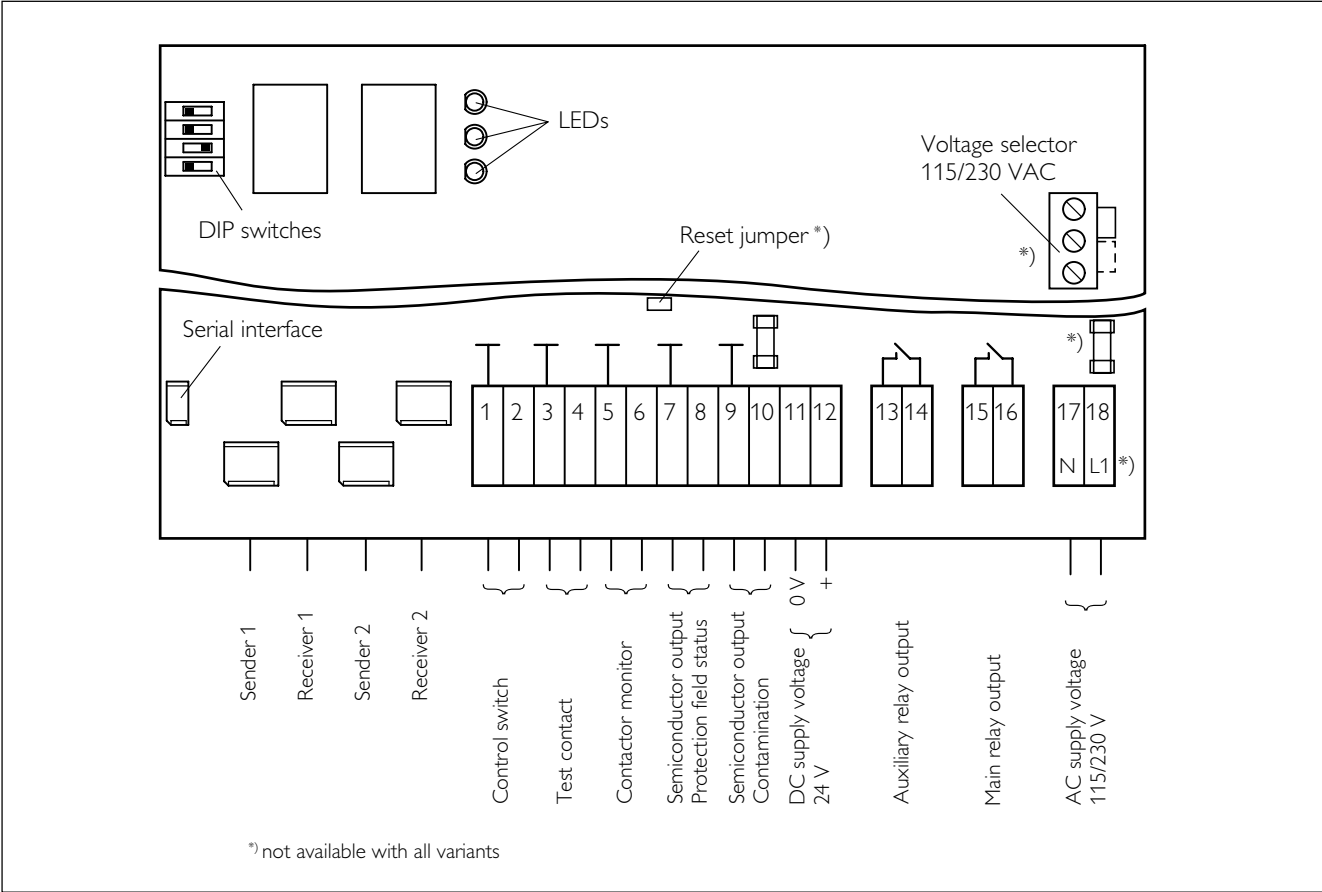

Fig. 29 LGTN connection diagram

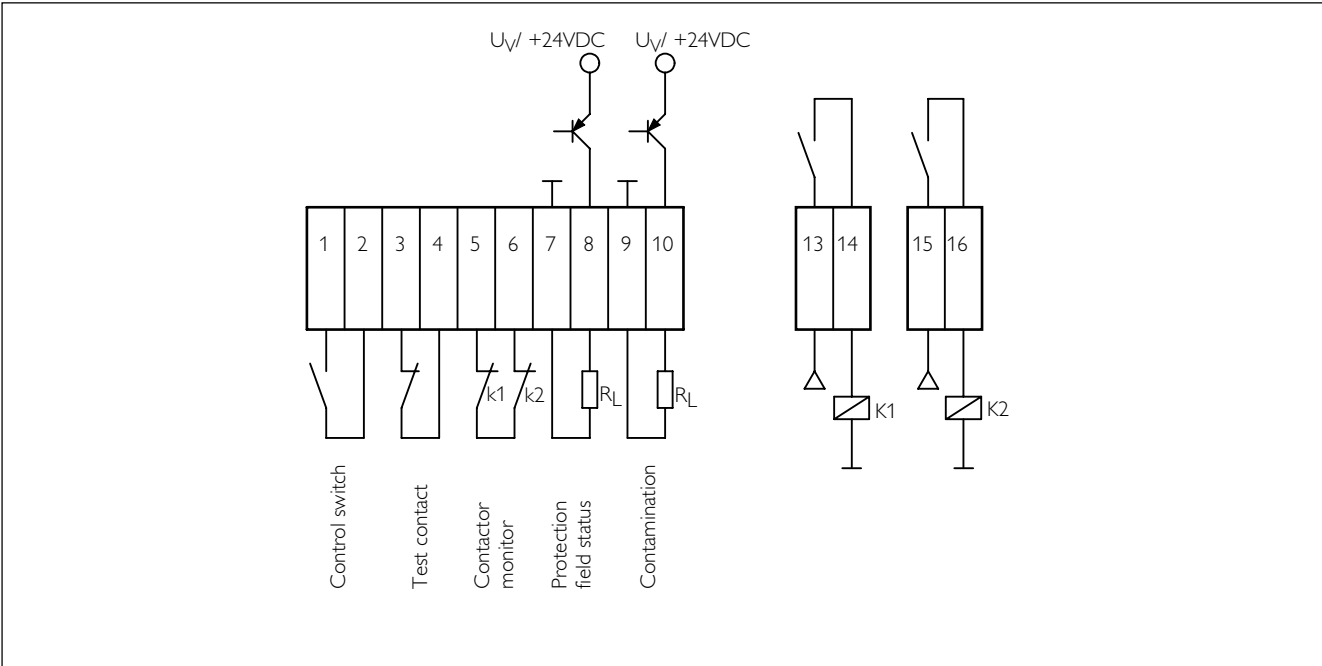

Fig. 30 Connection of two sensors

11 Safety Light Grid LGT Selection

11 Safety Light Screen LGT Selection

The following procedure should be used when selecting an active optoelectronic protective device:

	Action	Note
Regulations?	Refer to the relevant regulations, standards and requirements for the application.	The responsible authorities and professional associations can provide assistance here.
Protective zone width?	Determine the required width of the protective zone	The protective zone width is the width of the area which is to be safeguarded. The width must be selected in such a way that the hazardous areas can only be accessed through the protective zone.
Protective zone height?	Determine the required height of the protective zone	The protective zone height must be selected in such a way that the hazardous areas can only be accessed through the protective zone.
Resolution		The resolution determines the safety distance.

11.1 LGT Selection table

Protective field height in mm	Device type	Order no.
150	LGTS 015-051	1 013 413
	LGTE 015-051	1 013 414
300	LGTS 030-111	1 013 415
	LGTE 030-111	1 013 416
450	LGTS 045-171	1 013 417
	LGTE 045-171	1 013 418
600	LGTS 060-231	1 013 419
	LGTE 060-231	1 013 420
750	LGTS 075-291	1 013 421
	LGTE 075-291	1 013 422
900	LGTS 090-351	1 013 423
	LGTE 090-351	1 013 424

11.2 Control unit and Connection lead Selection Table

Type	Designation	Order no.
LGTN 101-511	Control unit 24 VDC	6 010 683
LGTN 101-311	Control unit 115/230 V AC/24 V DC	6 010 521
LGTN 101-521	24 V DC control unit for installation in a control cabinet	6 008 527
LGTN 101-321	115/230 V AC/24 V DC control unit for installation in a control cabinet	6 008 526
	Connection lead with socket 2.5 m	6 009 923
	5 m	6 009 924
	10 m	6 009 926

11.3 Accessories Selection Table

Type	Designation	Order no.
	Snap-on clip	4 028 654
	Test rod 30 mm	2 005 001
	Arc suppressor 110 to 230 V	6 001 224
	Arc suppressor 24 to 48 V	6 001 225

SICK

Checklist for Manufacturers/Fitters for the Installation of Active Opto-Electronic Protective Device (AOPD)

The information with regard to for the points listed below, must be available at least when the equipment is commissioned for the first time, and in accordance to depending, however, on the requirements of the application, for which the manufacturer/fitter must check.

This checklist shall be kept in a safe place or stored with the machine documents as a reference for furtherrecurring checks.

1. Were the safety regulations based on the guidelines/standards issued for the machine? Yes No
2. Are the applied regulations and standards listed in the Declaration of Conformity? Yes No
3. Does the protectiveon equipment meetcorrespond to the required control category? Yes No
4. Is the access to the danger area/danger pointspot only possible through the protectedive field of the protectiveon equipment? Yes No
5. When protecting securing the danger area/danger pointspots, were measures taken to prevent unauthorised protected entry into the danger area (mechanical entry prevention) or to monitor entry and are these measures secured to prevent removal? Yes No
6. Was additional mechanical protectiveon equipment installed which cannot be reached over, under or around? Is this equipment safeguarded against tampering? Yes No
7. Has the maximum stop time or delay of the machine been checked and indicated or documented (on the machine and/or in the machine documentation)? Yes No
8. Has the required safety distance of the protection equipment to the nearest danger pointspot been maintained? Yes No
9. Are the protectiveon devices equipment units mounted properly and secured against movement once they have been correctly successfully adjusted? Yes No
10. Does the required protectiveon equipment safeguard against electric shock (protection class)? Yes No
11. Is the control device for resetting the protectiveon equipment or restarting the machine present and fitted in accordance with the regulations? Yes No
12. Are the outputs of the protectiveon equipment (OSSD) integrated in accordance with the required control category and does this integration correspond to the wiring diagrams? Yes No
13. Has the protective function been checked in accordance with the notes on testing stated in this documentation? Yes No
14. Are the given protective functions effective for each setting of the operating mode selector switch? Yes No
15. Are the switching elements controlled by the protectiveon equipment, (e.g. contactors, valves) monitored? Yes No
16. Is the protectiveon equipment effective throughout the entire hazardous dangerous operation procedure? Yes No
17. Is an initiated hazardous dangerous operation procedure stopped when switching off the protectiveon equipment, when changing the operating mode or switching to other protectiveon equipment? Yes No

This checklist does not replace the first commissioning or regular checks carried out by an expert.

EC Declaration of Conformity

Under the terms of EC Machine Directive 89/392/EEC, Appendix II C

We hereby declare that the devices

of the product family LGT



are safety components for a machine constructed as per the EC directive 89/392/EEC art. 1 para. 2. This declaration will lose its validity if any modification to a device used in the plant is made without prior consultation.

We employ a quality system certified by the DQS (German Quality Assurance Society), No. 19 462-01, as per ISO 9001 and have therefore observed the regulations in accordance with module H as well as the following EC directives and EN standards during development and production:

1. EC directives	EC machine directive 89/392/EEC, as per 91/368/EEC, 93/68/EEC, 93/44/EEC EC low voltage directives 73/23/EEC, as per 93/68/EEC, 93/465/EEC EC EMC directive 89/336/EEC as per 92/31/EEC, 93/68/EEC, 93/465/EEC		
2. Harmonized standards and preliminary standards used	EN 292-1 & -2	Safety of basic machine structure	Ed. 91-09
	EN 60204-1	Electr. equip. of mach.	Ed. 92-10
	prEN 60100-1 & -2	Safety of mach., active opto-electronic protective devices (AOPD)	Ed. 94-05
	EN 50082-2	Immunity, indust.	Ed. 96-02
	EN 50081-1	Emitted interference, domestic, industrial, small industry	Ed. 94-03
3. Applicable german regulations	FN 954-1	Safety-related components of controllers	Ed. 97-03
	ZH1/597	For AOPD on powered equipment	Ed. 79-10
4. Test result	prEN 50100	(AOPD) Type 2	

Conformance of a type sample belonging to the above-mentioned product family with the regulations from the listed EC directives has been certified by:

Address of notified authority (Germany) TÜV Rheinland Product Safety GmbH
Am Grauen Stein
D-51105 Köln

EC type sample test No. BB 9710928 01 dated 1997-07-31

The CE label has been attached to the device as per the directives 73/23/EEC, 89/336/EEC, and 93/68/EEC.

Waldkirch/Br., 1997-11-24

ppa. Windau
(Head of Sales & Marketing
Division Safety Systems)

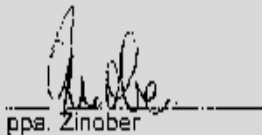
ppa. Zinöber
(Head of Production
Division Safety Systems)

The declaration certifies conformance with the listed directives, but does not guarantee product characteristics. The safety instructions contained in the product documentation must be observed.

SICK AG
Sebastian-Kneipp-Str. 1
D-79183 Waldkirch

Telefon (0 78 81) 202-0
Telex 772014
Telefax (0 78 81) 58 63

Anbindlungsstellenleiter
Dr. Horst Skoludek
Vorsitzend
Volker Kevcke (Vors.)
Anne Kathrin Deutrich
Dieter Fischer

Stz. Waldkirch i. Br.
Handelsregister
Firmenregister HRB 355 W

Your contacts:

Australia

Phone +61/3 94 97 41 00
008/33 48 02 – toll free
Fax +61/3 94 97 11 87

Austria

Phone +43/2 23 66 22 88-0
Fax +43/2 23 66 22 88-5

Belgium/Luxembourg

Phone +32/24 66 55 66
Fax +32/24 66 60 26

Brazil

Phone +55 11/55 61 26 83
Fax +55 11/5 35 41 53

China/Hong Kong

Phone +8 52/2763 69 66
Fax +8 52/2763 63 11

Czech Republic

Phone +42 02-578 10 561
Fax +42 02-578 10 559

Denmark

Phone +45/45 82 64 00
Fax +45/45 82 64 01

Finland

Phone +3 58/9-7 28 85 00
Fax +3 58/9-72 88 50 55

France

Phone +33/64 62 35 00
Fax +33/64 62 35 77

Germany

Phone +49 76 81/2 02-0
Fax +49 76 81/2 02-38 15

Great Britain

Phone +44/1727-83 11 21
Fax +44/1727-85 67 67

Italy

Phone +39/02-92 14 20 62
Fax +39/02-92 14 20 67

Japan

Phone +8 13/33 58-13 41
Fax +8 13/33 58-05 86

Netherlands

Phone +31/3 02 29 25 44
Fax +31/3 02 29 39 94

Norway

Phone +47/67 56 75 00
Fax +47/67 56 66 10

Poland

Phone +48/2 26 44 83 45
Fax +48/2 26 44 83 42

Singapore

Phone +65/7 44 37 32
Fax +65/8 41 77 47

Spain

Phone +34/9 34 80 31 00
Fax +34/9 34 73 44 69

Sweden

Phone +46/8-6 80 64 50
Fax +46/8-7 10 18 75

Switzerland

Phone +41/4 16 19 29 39
Fax +41/4 16 19 29 21

Taiwan

Phone +88 62/23 65 62 92
Fax +88 62/23 68 73 97

USA

Phone +16 12/9 41-67 80
Fax +16 12/9 41-92 87

Representatives and agencies
in all major industrial nations.

SICK

SICK AG • Safety Systems • P.O. Box 310 • D-79177 Waldkirch
Phone +49 76 81/2 02-0 • Fax +49 76 81/2 02-38 15 • <http://www.sick.de>