

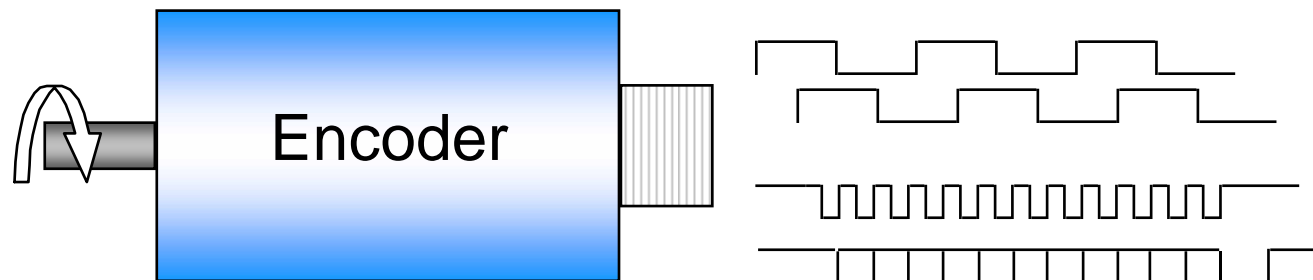

Motorfeedback Systeme
Motorfeedback Systeme

What is an Encoder?

An Encoder is a device which converts a mechanical information (position = angle) of a shaft into an electrical signal



Different models of Encoders

The selection criteria is:

- Interface
 - electrical
 - mechanical
- Application
- Resolution / Accuracy

How is being measured

Magnetically

- robust
- less/middle resolution
- low price

Inductive / capacitive

- special environmental requirements

Optically

- high / highest accuracy
- mechanical sensitivity
- condensation

Electrical interface

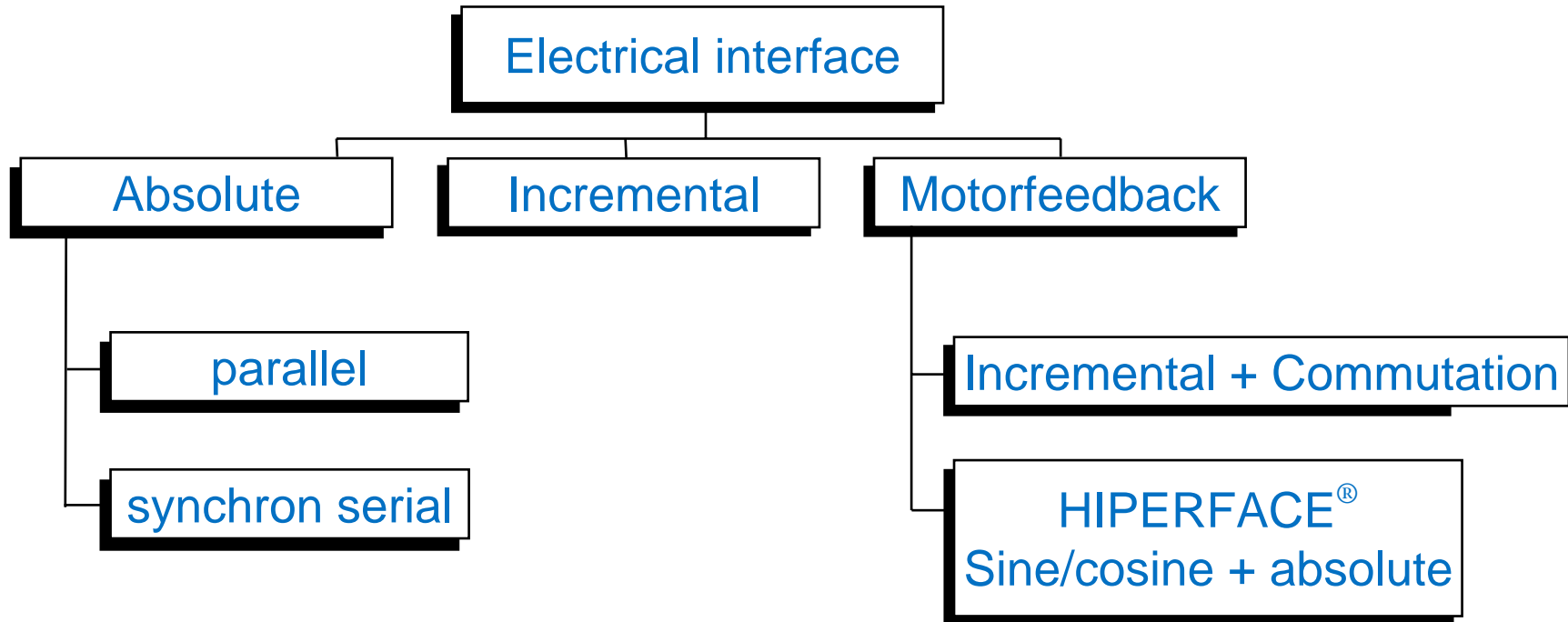

Mechanical interface

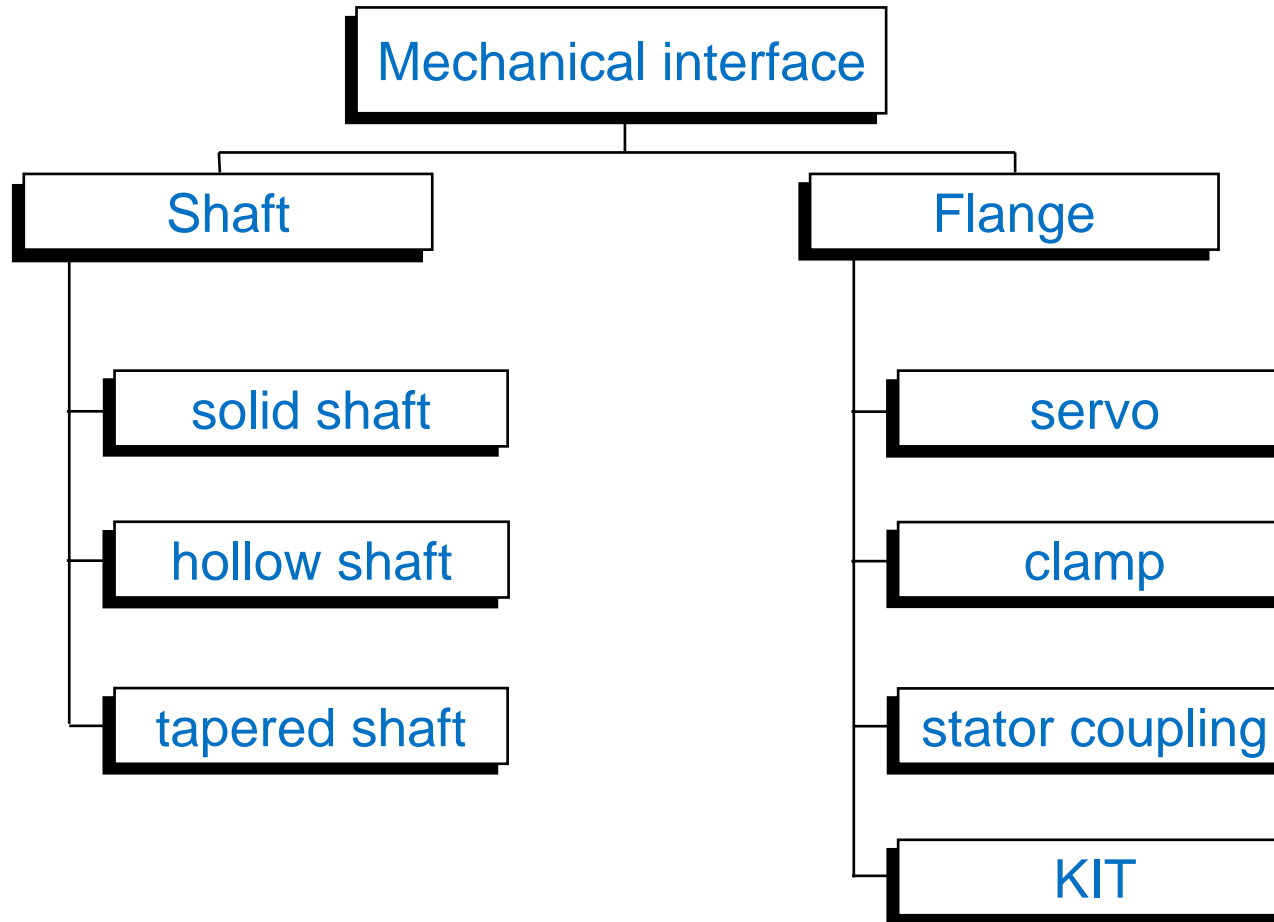

Basic components of magnetic encoders

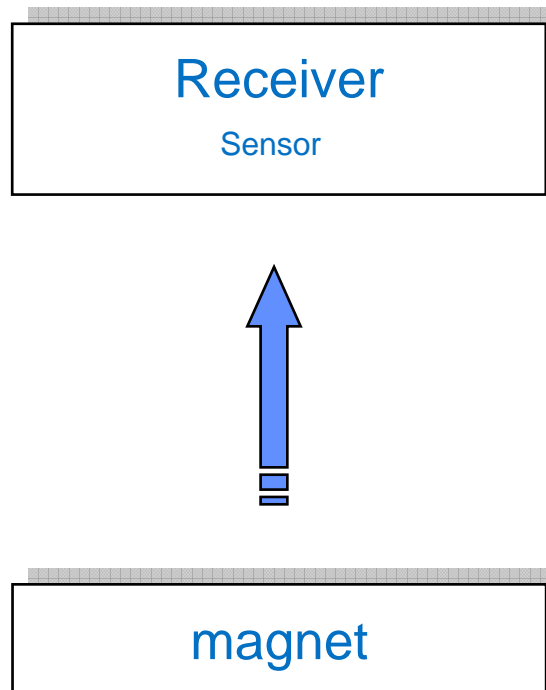

Basic components of optic encoders

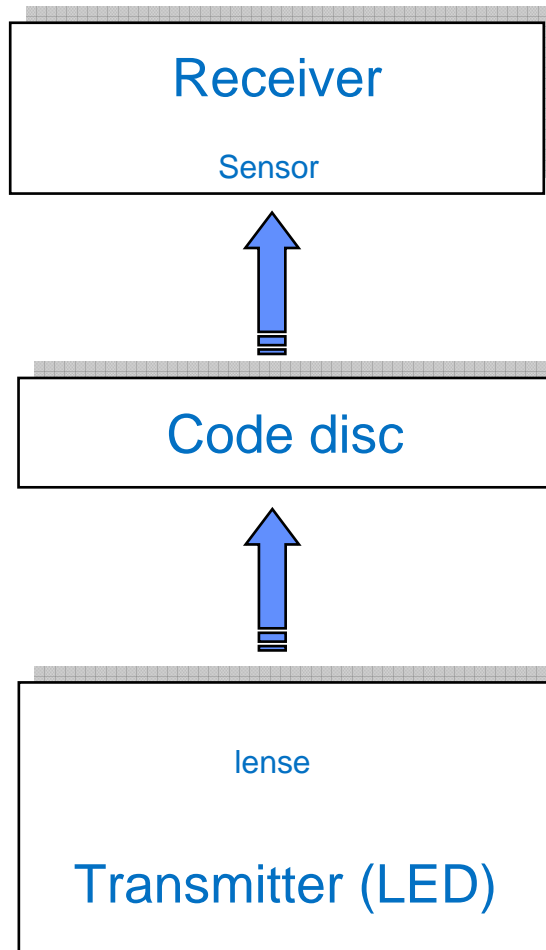

Motorfeedbacksystems at servo motors in the past

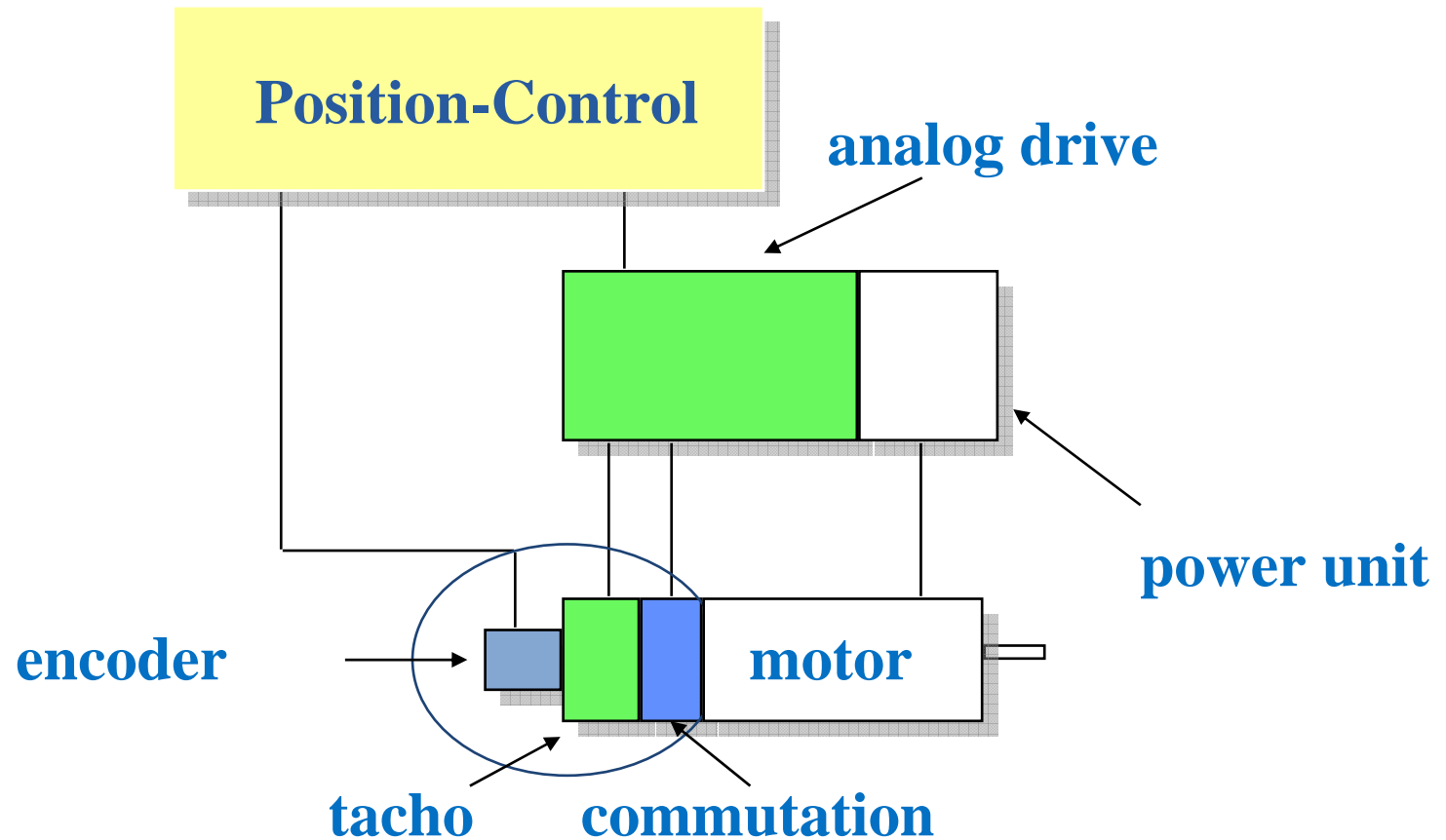

Disadvantage of Motorfeedbacksystems at servo motors in the past

- A motorfeedbacksystem consists of 3 devices
- Therefore up to 4 cable connections required
- In total there are a minimum of
 - 6 connections for the encoder,
 - 2 connections for the tacho,
 - 5 connections for the commutation and
 - 4 connections for the motor
 - (plus 2 connections for the temperature sensors)
- ☞ In total 19 connections necessary.
- The encoder is always connected with the Position-Control unit.

Motorfeedbacksystems at servo motors today

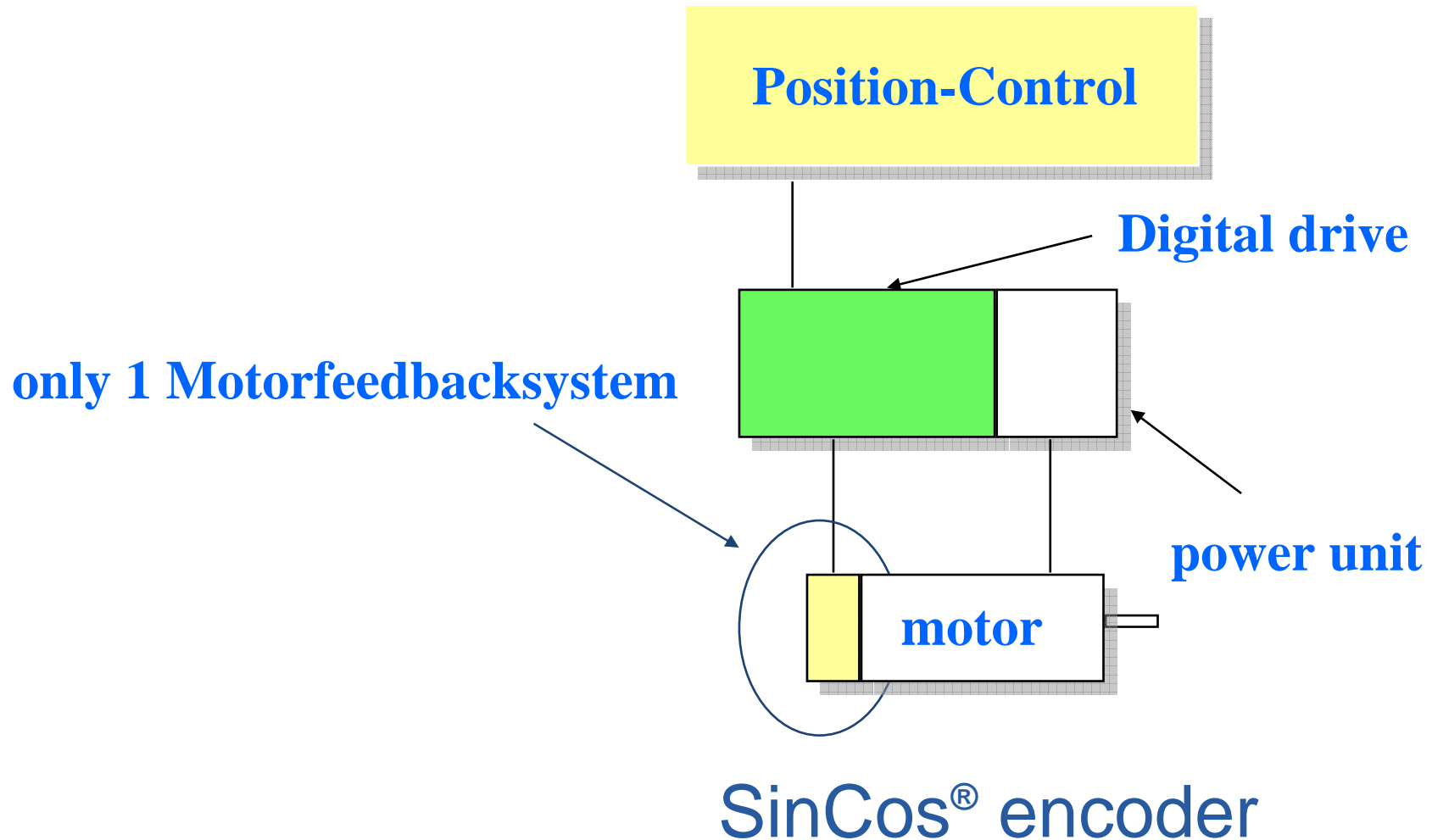

Evolution of Motorfeedback Systems

Present

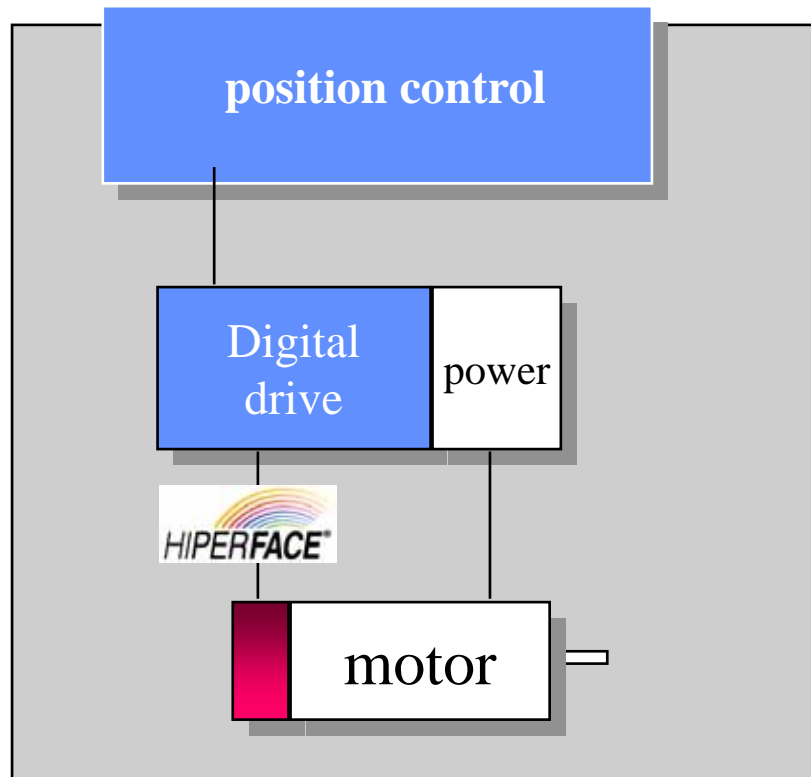

Past

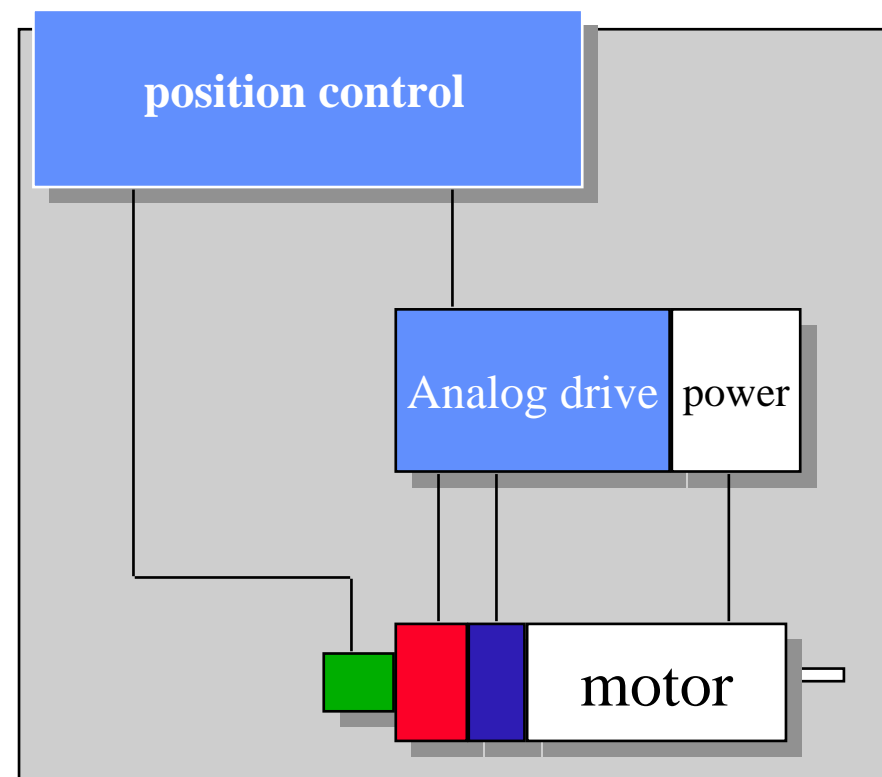

Basic functions of Motorfeedback Systems (MFB)

Provides control and feedback relevant data for servo drives by converting the angle into an electrical signal

- ▶ **Speed measurement**
- ▶ **Angle measurement for commutation**
- ▶ **Angle measurement for positioning**

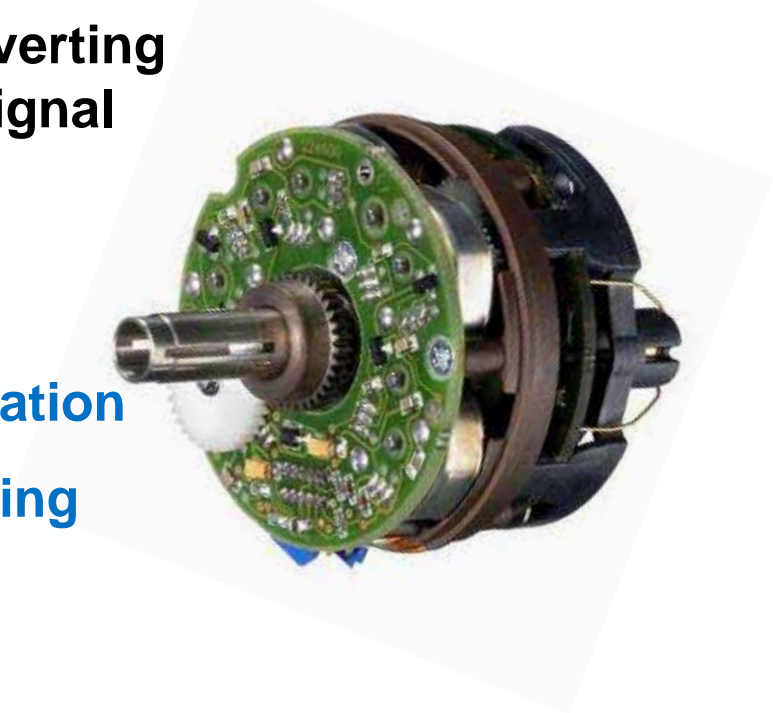

SinCos[®] system characteristics

- Resolution of the rotation angle up to a few million steps / revolution
- Linearity of the rotation angle of 10^{-5} of one revolution
- Angle information absolute, over 4096 revolution
- Pure P - behaviour of the system
- high electromagnetic compatibility (EMC),
 - ☞ direct use within a servo motor possible
- High temperature range of -20 up to +125° celsius

Functionality of single -and multiturn devices in magnetical construction

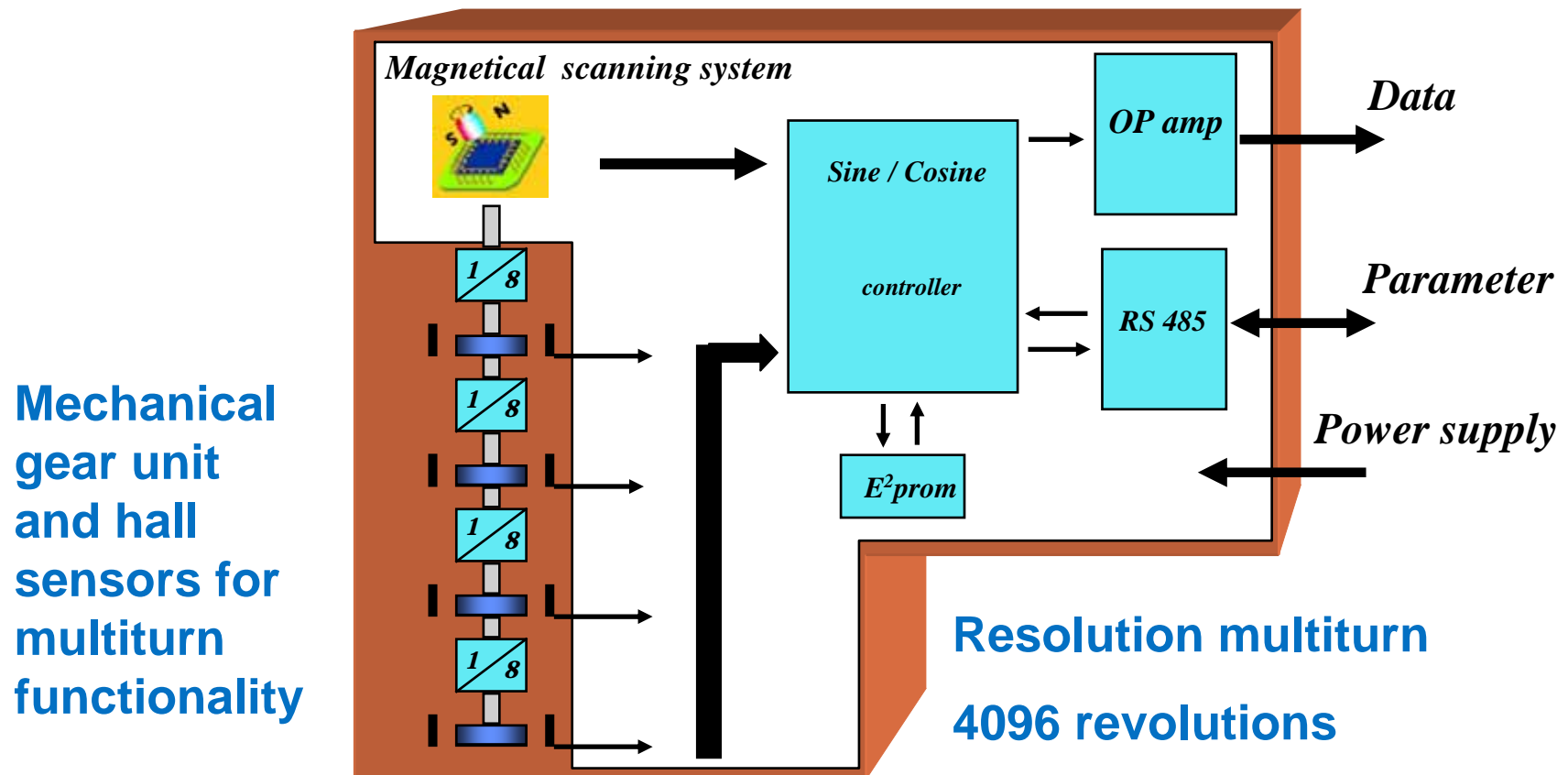

Hardware configuration of a multi turn encoder

Certain gear transmission
Ratio for 4096
turns in total

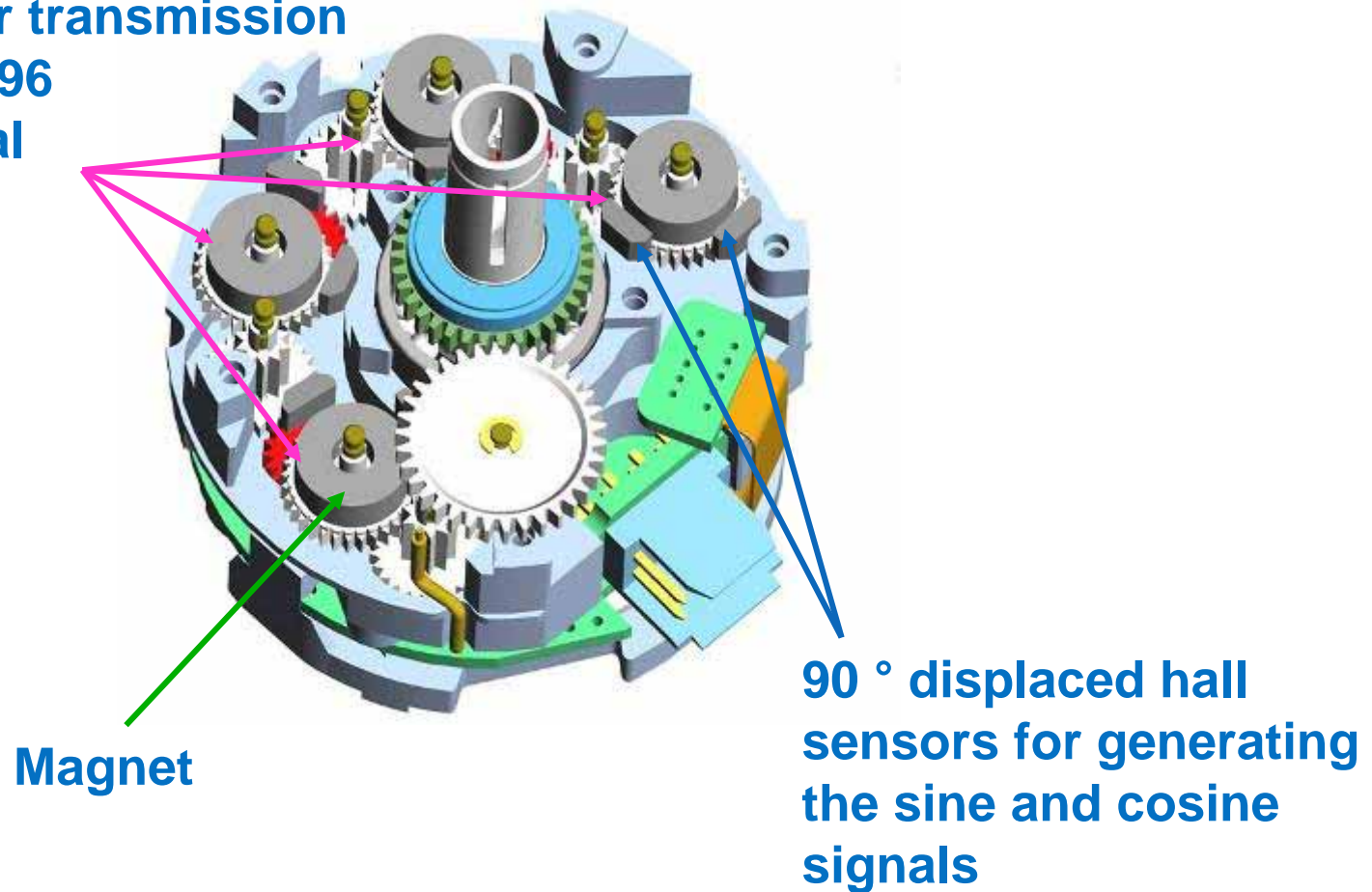

Mounting possibilities on a motor

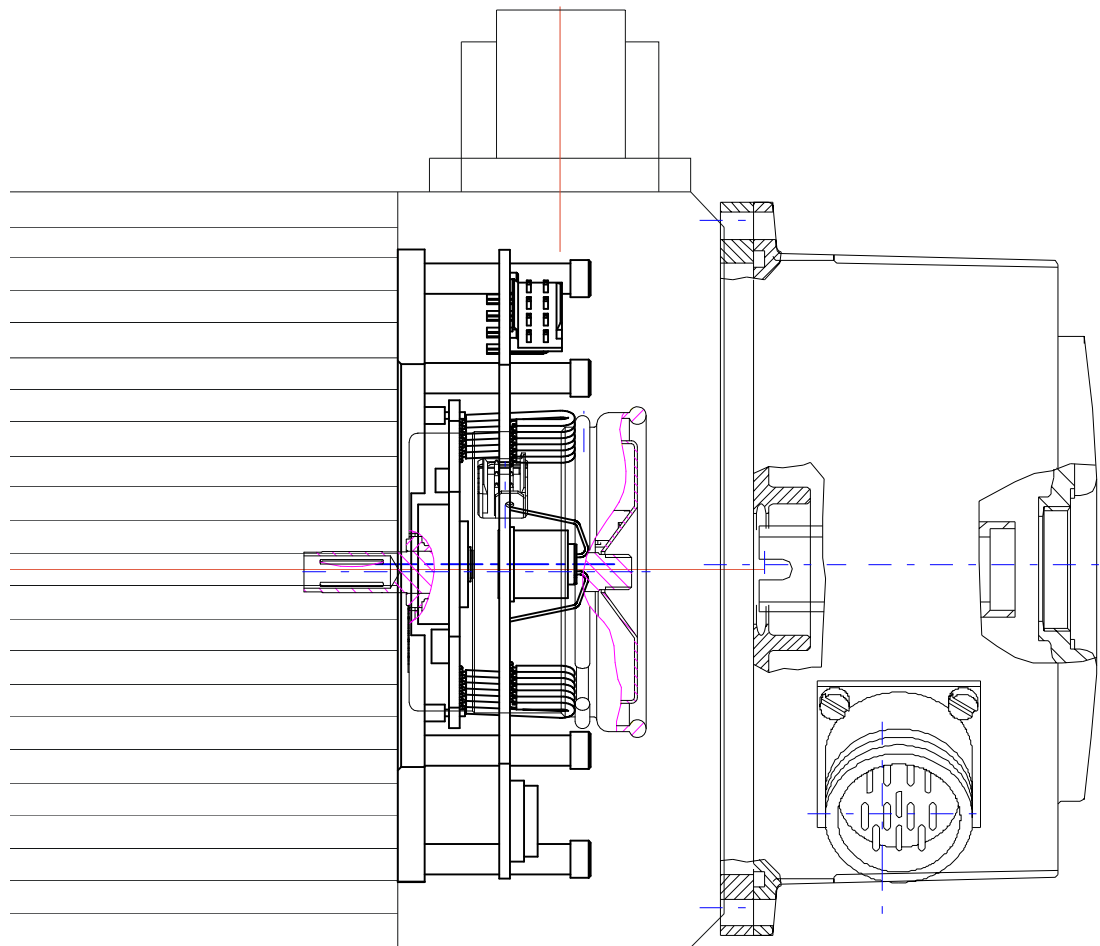

- Build on encoder e.g. SCS/M70 ...A
- Hollow shaft-KIT e.g. SCL/SCK
- Build in encoder e.g. SRS/M 50

The electrical interface

For the electrical interface HIPERFACE® is used

- **High Performance Interface**
- **The physical interface used between Stegmann SinCos® encoders and digital drives**
- **Initially developed for brushless servo systems. Now increasingly being used to improve the performance of A.C. induction motors as well**

Schematic HIPERFACE®

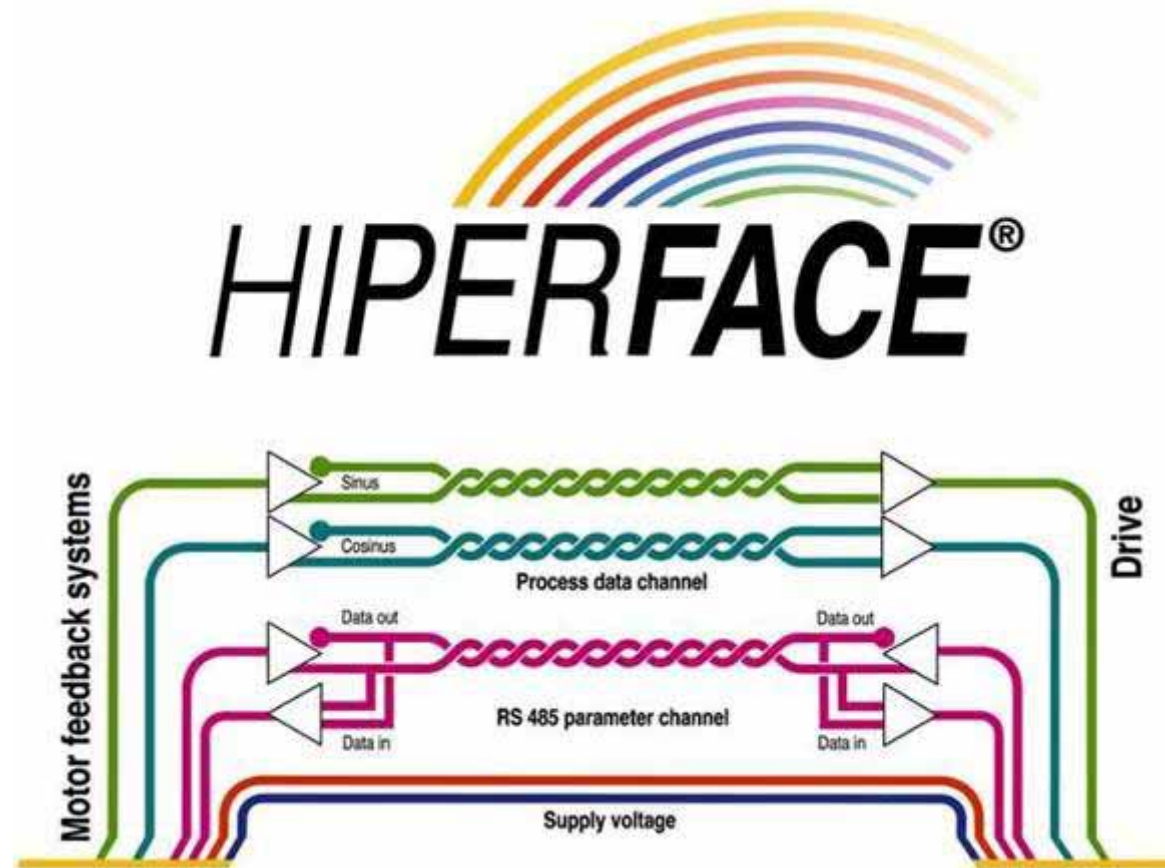

The HIPERFACE[®] interface

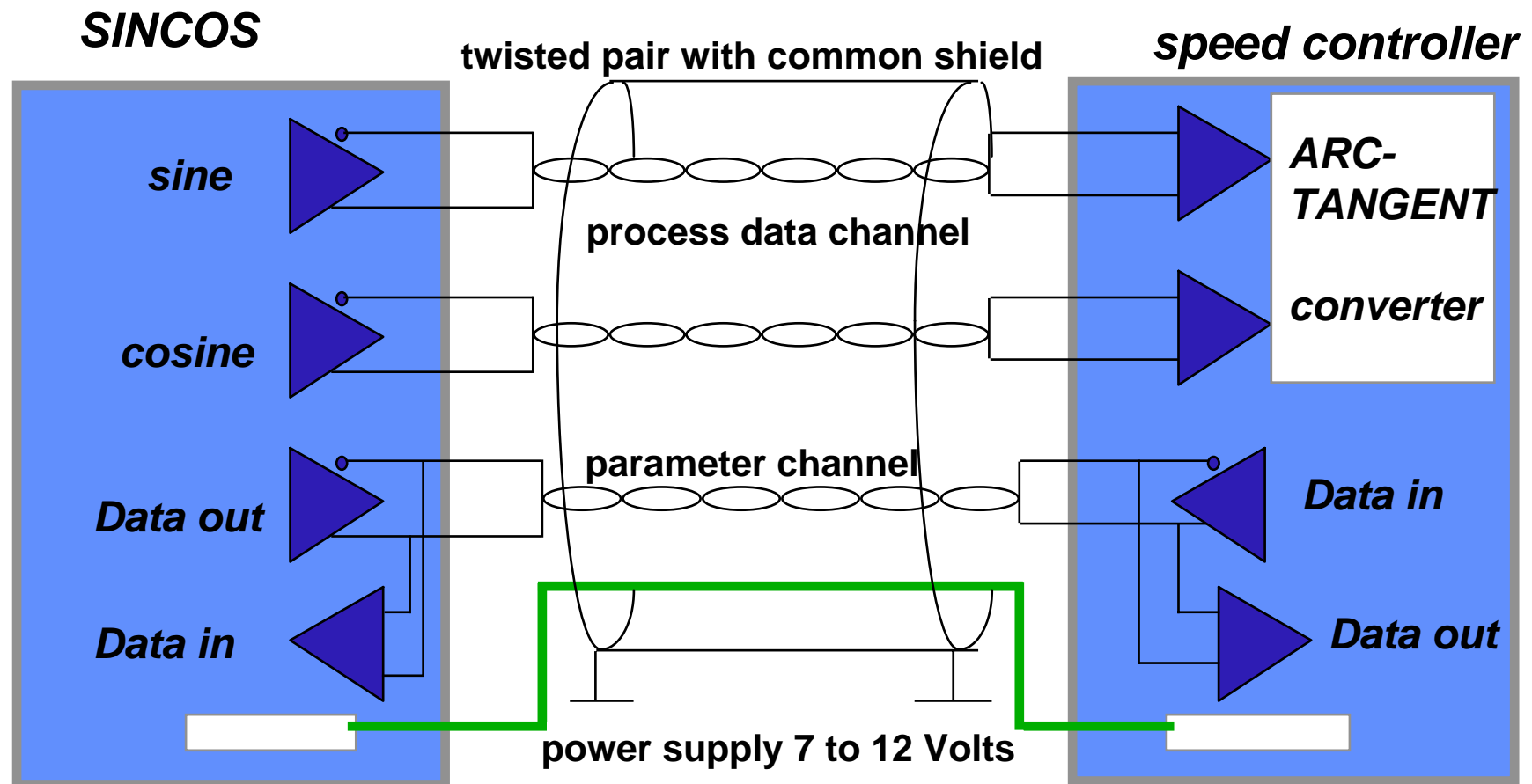

Physical definition of the parameter channel

- half duplex interface, bus possibility
- physically EIA RS 485 specification

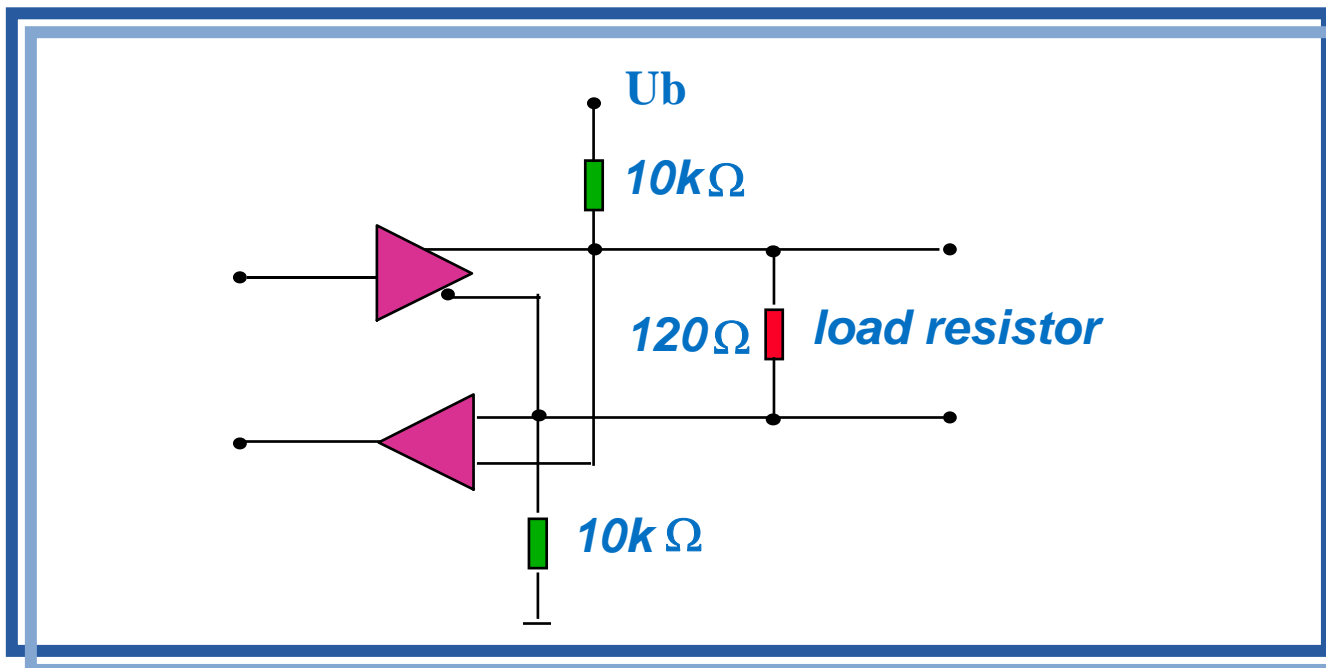

Physical definition of the process data channel

- fully differential signals
- 1Vpp

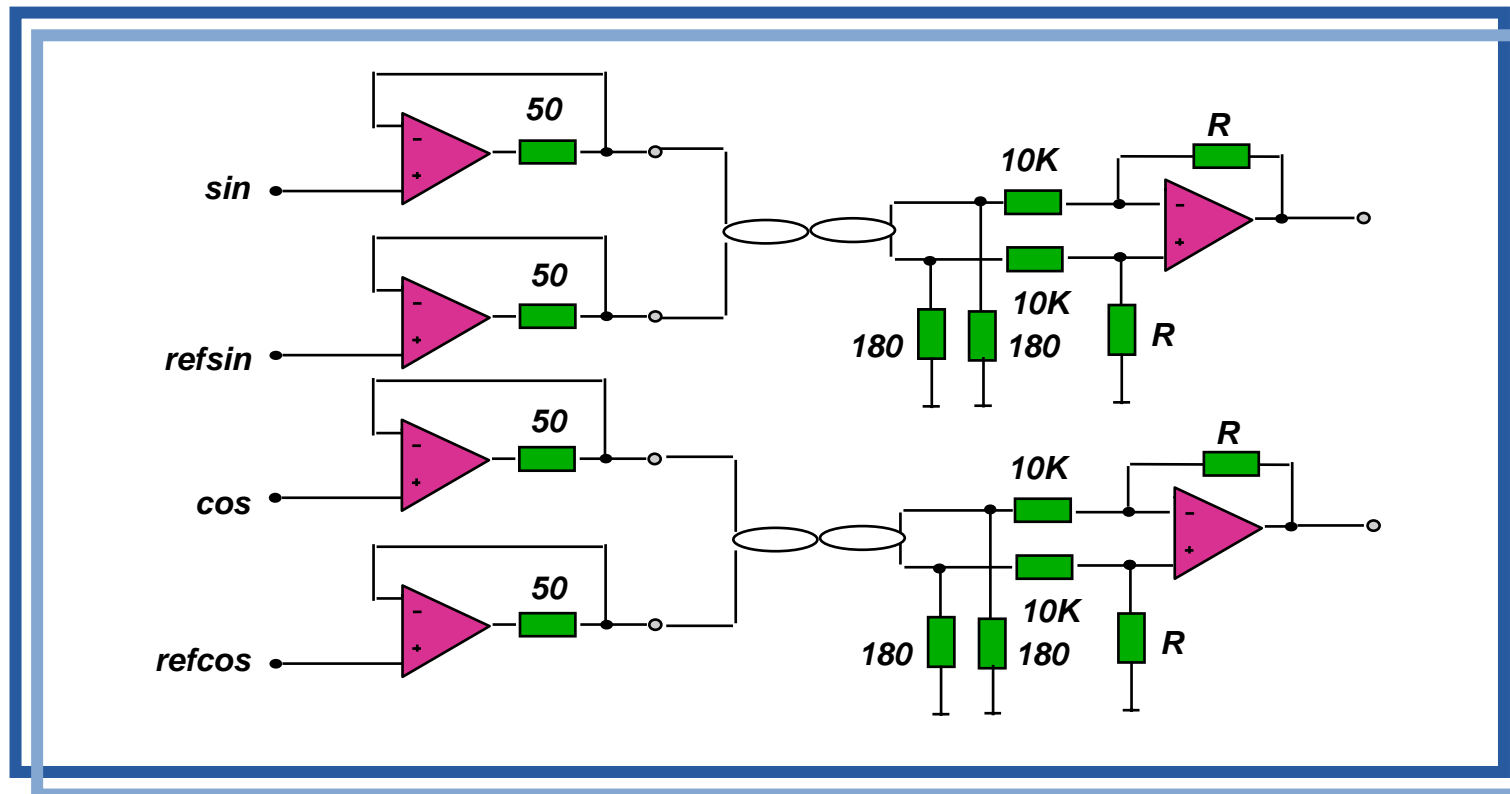

What are the benefits of HIPERFACE® encoders ?

- Excellent regulation of speed even at very slow speeds
- Absolute positioning avoiding time consuming axis initialisation
- Long distance data transmission due to 7 - 12V supply and differential data transmission
- Automatic recognition of the motor type - due to storage of motor specific data within the encoder
- Automatic recognition of encoder connected - due to electronic label
- High temperature capability - due to special pick-up system and ASIC's

Further benefits of HIPERFACE[®] encoders ?

- Sine²+cosine² light regulation
- Selftests
- Redundancy
- No mechanical commutation adjustment necessary
- World wide acceptance

LAFERTGROUP

Motion & Control **AEG**

OMRON

BAUMÜLLER

Dr.-Ing. S. Haußmann
Industrieelektronik

SEW EURODRIVE

oemler
elektrotechnische
diagnostik

MAVILOR

metronix

S
System-Antriebstechnik
Drive&Control

OSWALD
REGELBARE ELEKTROMOTOREN

BAUTZ
Antriebs- und Steuerungstechnik

EUROTHERM ANTRIEBE

Schneider
Electric

EPA

GROSCHOPP

Jetter mayr

Stromag
Spezialantriebe für Kran- und Förderanlagen

BERGER LAHR
contigates drives

BECKHOFF

ELAU

SEM
Controlled Motion Technology

EPH elektronik

Harmonic Drive

KEB
ANTRIEBSTECHNIK

MTS
MTS Automation
Custom Drive Motors

ANDRIVE
Antriebs- und Steuerungstechnik

drive

ANALOG DEVICES

ABB

SEM

EPH elektronik

Harmonic Drive

KEB

MTS

PACIFIC SCIENTIFIC
HIGH PERFORMANCE MOTORS & DRIVES

BALDOR
MOTORS AND DRIVES

ABB

DDC
Data Device Corporation

ABB

SEM

EPH elektronik

Harmonic Drive

KEB

MTS

WITTENSTEIN
Motion Control GmbH

QUIN

DELTA TAU
DATA SYSTEMS, INC.

HIPERFACE

ESR

KOLLABORIEREN
Seidel

Rexroth
Bosch Group

DriveTech GmbH

CONTROL TECHNIQUES
www.controltechniques.com

ABB

SEM

EPH elektronik

eurolab

Lenord + Bauer

SANYO DENKI

bmp
baldor motor division

SCIWORX
Motor feedback systems

NUM
Motion Control

SEM

EPH elektronik

HDD
High Density Drives

Lenze

osai
DYNAMIC ELECTRONICS

Rockwell Automation
Allen-Bradley

YASKAWA
Motion Solutions

bmp

ZIEHL-ABEGG

NUM

SEM

EPH elektronik

Industrie-Elektronik

LERROY SOMER

S.B.C.
MOTOVARIATORI

SIEI

Beldrive

Systems

SMB
Servomotorien & Elektronik GmbH

EB&MEYER

INFRANOR

LUST
ANTRIEBSTECHNIK

ANDRIVE

ENGEL
Servo-Antriebe GmbH

Octo COM

STOBER

AMK

SSB
ANTRIEBSTECHNIK

ferrocontrol

INFRANOR

MACON
MOTION UNDER CONTROL

MOTOR POWER COMPANY

SERVAX
DRIVES
A Division of Landert-Motoren AG

GEORGIN KOBOLD

IRL

Motorfeedback-Systems

SICK | STEGMANN

Applications

for internal use only

Printing Machines



Machine Tools



Semiconductor manufacturing Devices

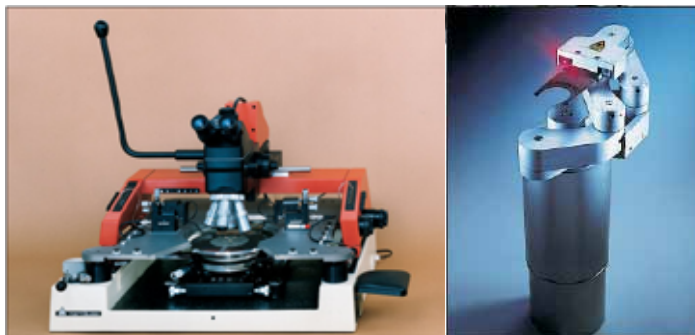

Packaging Machines



for internal use only

Applications

Woodworking and Plasticworking Machines



Welding Gun

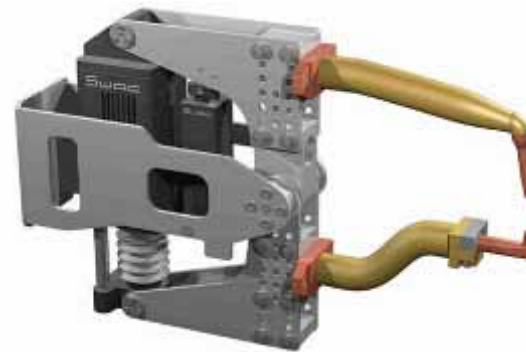

Winding Machines



Telecommunications



Classworking Machine



HIPERFACE[®] PRODUCTS

(CNS 50)

SRS / SRM 50 SinCos[®]

SHS 17 SinCos[®]

SCK SinCos[®]

SCL SinCos[®]

SKS / SKM 36 SinCos[®]

SRS / SRM 64 SinCos[®]

(SCS / SCM 60,70 SinCos[®]) Product phase out



CNS 50

Incremental encoder + commutation signals

possible resolutions: 1000 / 1024 / 2000 / 2048 / 4000 / 4096 ppr
possible pole pairs: 2 / 3 / 4 / 6 / 8



SRS / SRM 50 SinCos[®] encoder

1024 sin/cos periodes / rev.
32768 absolute positions / rev.
4096 revolutions



SCK SinCos[®] encoder

1024 sin/cos periodes / rev.
32768 absolute positions / rev.



**HIPERFACE[®]**

SCL SinCos[®] encoder

1024 sin/cos periodes / rev.
32768 absolute positions / rev.
4096 revolutions



SKS / SKM 36 SinCos[®] encoder

128 sin/cos periodes / rev.
4096 absolute positions / rev.
4096 revolutions



HIPERFACE[®]



SRS / SRM 64 SinCos[®] encoder

1024 sin/cos periodes / rev.
32768 absolute positions / rev.
4096 revolutions



HIPERFACE[®]



SCS / SCM 60,70 SinCos[®] encoder

512 sin/cos periodes / rev.
16384 absolute positions / rev.
4096 revolutions



**HIPERFACE[®]**

What is a resolver?

A type of rotary transformer consisting of a series of coils



It produces 1 Sine/Cosine period per revolution

When fed into an R-D converter (resolver to digital converter). The Signals produced are;

- Single turn absolute data (for commutation)
- A simulated incremental encoder signal (for incremental positioning and speed regulation)

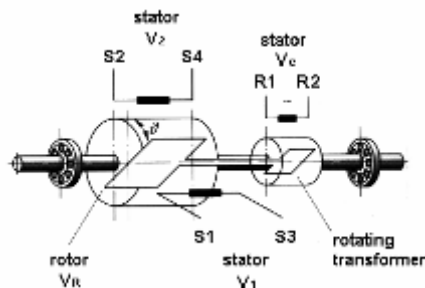

Sick|Stegmann do not make resolvers

How does a Resolver work?

There are rotor coils and stator coils

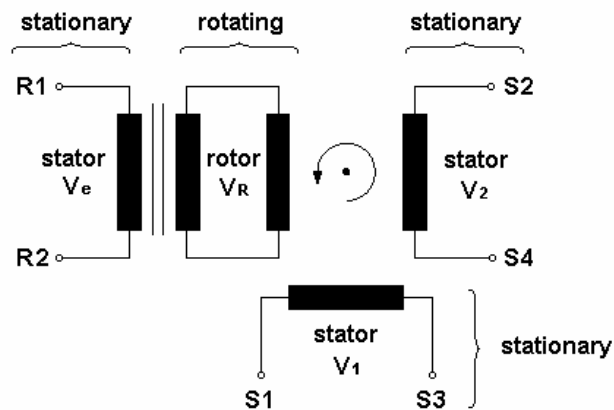

A Sine wave with a frequency of around 8KHz and an amplitude of 10V is applied to R1.

This signal is induced into the rotor winding. (rotary transformer effect)

The rotor winding as it turns induces a signal into the 2 stator windings offset by 90 degrees

These signals are modulated Sine and Cosine signals

The resolver signals

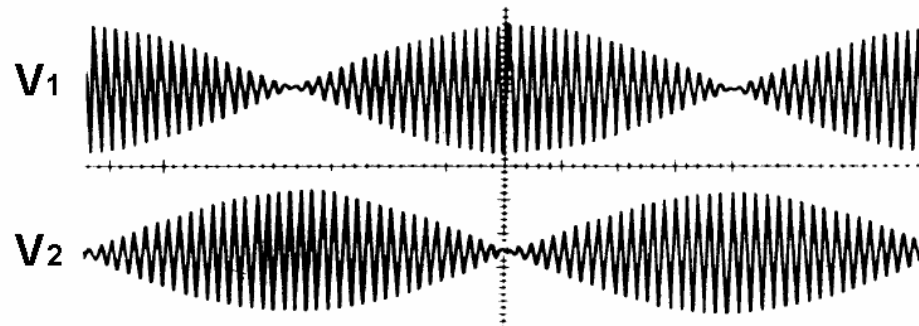

When demodulated in the R-D converter a pure Sine and Cosine wave is produced. The period length is 360 mechanical degrees.

A single Sine/Cosine wave can be evaluated to produce absolute positional data

Advantages and disadvantages of the resolver

Advantages

- Low cost device
- Robust device (only coils)
- Tolerant to radiation and condensation

Disadvantages

- Limited resolution due to single Sine/Cosine wave. Typ 4096ppr
- Limited accuracy due to mechanical construction. Typ 15 arc min
- Time delay introduced to feedback loop due to effect of demodulation.
Reduced dynamic performance.
- Only Single turn. No multi-turn option
- No further development of the technology feasible
- Special cable required. Twisted pair with individual screens

Document Revision History

Date	Version	History
21.08.2003	1.00	first issue
01.12.2003	1.01	review
04.02.2004	1.02	review
12.05.2005	1.03	review
14.06.2005	1.03	review

Document and Order Information

Reference	Value
File	MFB_Präsentation.PPT_ver103
Title	MFB_Präsentation
Release	1.03
Valid as of	12.05.05

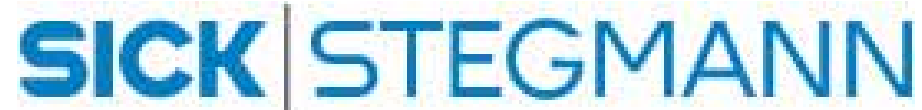

SICK Stegmann GmbH
Dürrheimer Straße 36
78166 Donaueschingen
Germany

Phone: +49 (0)771 807 - 0
Fax: +49 (0)771 807 - 100
Email: info@sick-stegmann.de

Resolver via SinCos®

